

COMPRESSION TUBE FITTINGS

LET-LOK[®]

1/16" THROUGH 2" 2 MM THROUGH 50 MM



LET-LOK® TUBE FITTINGS DESCRIPTION

The **HAM-LET®** GROUP has produced high quality tube and pipe fittings in various materials for high pressure applications since its establishment in 1950.

As a result of tremendous efforts in research and development during the last five decades, **HAM-LET®** has gained an excellent reputation as a leading manufacturer of high pressure instrumentation products.

The **LET-LOK®** range of connectors has been developed to fill the rapidly increasing demand for tube fittings suitable for high pressure use in environments such as petrochemical, fluid, power, nuclear, electronic, as well as other major industrial settings.

LET-LOK® tube fittings have been carefully manufactured to withstand the persistent demands for high-performance tube fittings. Each one has passed a stringent tolerance test for high pressure, impulse, vibration, vacuum and temperature. These precision-machined fittings are manufactured to exacting standards, employing the most modern state-of-the-art computerized automation. All **LET-LOK®** fittings are backed by **HAM-LET®**'s commitment to the highest quality-control standards and skilled craftsmanship.

LET-LOK® HOW DOES IT WORK?

The **LET-LOK®** tube fitting is a mechanism used both to seal and to grip tubing. The mechanical advantage and geometry of this kind of fitting produces a leak-tight assembly.

To assemble, simply insert the tube into the complete assembly until the tube bottoms-out against the shoulder of the fitting body (1). The two ferrules are driven forward between the nut (4) and fitting body using the mechanical force created by rotating the nut clockwise. The back ferrule (3) is driven against the tapered rear of the front ferrule (2) and the front ferrule is driven by force into the tapered mouth of the body.

The rear ferrule is swaged radially inwards on the tube while lifting the front ferrule out to form a full-faced seal on the tapered surface of the body.

The 1 1/4 turn of the nut from the hand tight position assures consistent drive of the sealing members. This ensures an effective seal against high pressure as well as ultra high vacuum conditions.

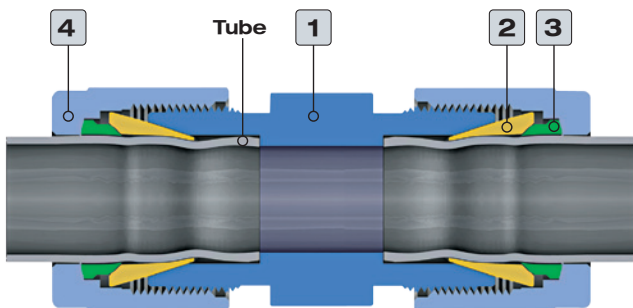

LET-LOK TUBE FITTINGS CONSIST OF FOUR PARTS:
1. BODY 2. FRONT FERRULE 3. BACK FERRULE 4. NUT



LET-LOK® FITTINGS INSTALLATION INSTRUCTIONS

LET-LOK® fittings are supplied assembled and finger tight. Disassembly before use can allow the entry of dirt or other particles.



Insert the tubing into the LET-LOK® fitting.

Check that the tube rests firmly on the fitting shoulder and that the nut is finger tight. At this point it is recommended that a scribe mark be drawn on the hex of the nut extending onto the fitting body. This mark will serve as an indicator for the starting point and proper pull-up.

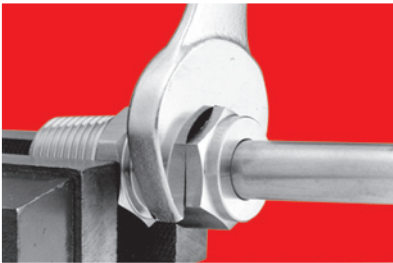

Tighten the nut.

1-1/4 turns of the nut are required for 1/4" (6 mm) and higher (see Fig. A). 3/4 turn of the nut is required for 3/16" (4 mm) and lower (see Fig. B).

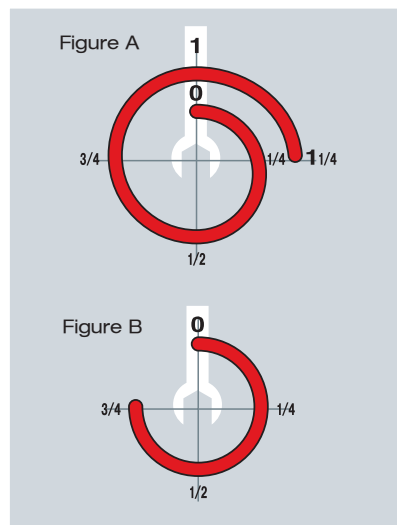

REASSEMBLY INSTRUCTIONS

LET-LOK® connections may be disconnected and remade repeatedly, without loss of leaktight seal.

1. Before disconnecting, mark the position of the nut in relation to the fitting body.
2. To reassemble, use a wrench to tighten nut to original position.
3. Tighten slightly with a wrench until a slight rise in torque is felt.

TUBE CUTTING

Two different methods can be used to cut tubes

1. Tube Cutter
2. Hacksaw

TUBE CUTTER

To attain a leak free connection, the tubing must be cut squarely. A good quality tube cutter with an appropriate blade for tubing material is recommended. Do not try to reduce the time of cutting by taking deep cuts with each turn of the cutter. This will work harden the tube.

The end of the tube must be deburred to avoid damage to the fitting and to ensure that the tube reaches the bottom of the fitting.

HACKSAW CUTTING

In order to cut the tube with a hacksaw and get square ends, the tube must be cut with guide blocks.

This method of cutting necessitates deburring of the tube ends.

Warning

Do not hold the tube in a vise in the place where it will be inserted into the fitting (the vise will leave a mark on the tube that may cause leaks, and might cause ovality).

TUBE HANDLING

Scratches on the tube might cause leaks. It is, therefore, important to handle the tube carefully to reduce the risk of leaks.

SOME PRECAUTIONS TO BE TAKEN

1. Tubes must not be dragged on the floor.
2. Tubes must not be dragged out of a tubing rack, especially in case of large OD tubes.

COPPER TUBING

If using copper tubing from a roll, hold the end of the tube and roll the roll outwards allowing the tubing to lie on a flat surface.

INSPECTION GAUGE

Use: This is a "No-Go" gauge and should be used as follows:

1. Make up the fitting according to the following instructions:
1/4 inch (6mm), 3/8 inch, 1/2 inch (12mm) make up 1-1/4 turns from finger tight.
2. Check gap between nut and body, using the appropriate sized gauge. If the gauge slides easily into the gap, tighten the nut further until gauge cannot enter the gap.

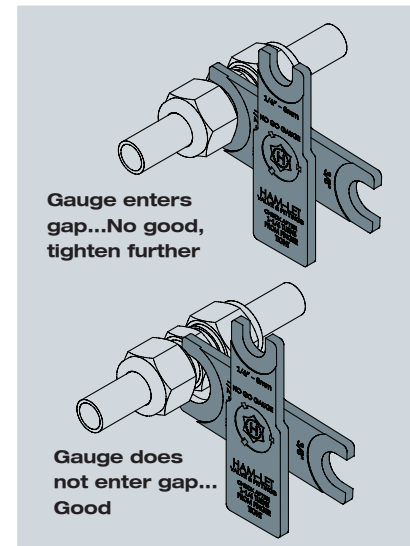

For Gauge Ordering Information: See page 89

LET-LOK® FITTINGS INSTALLATION INSTRUCTIONS

PHYSICAL DIFFERENCES AND MARKINGS

LET-LOK® METRIC FITTINGS:

Tee & Elbow (see Fig. 1)
Body marked: MM
Straight Connectors: (see Fig. 2)
Body: Stepped shoulder
Marked: LET-LOK 316 AV1⁽²⁾
Nut: (see Figs.1 & 2) Stepped shoulder
Marked: LET-LOK 316 6M⁽¹⁾ SD8⁽²⁾

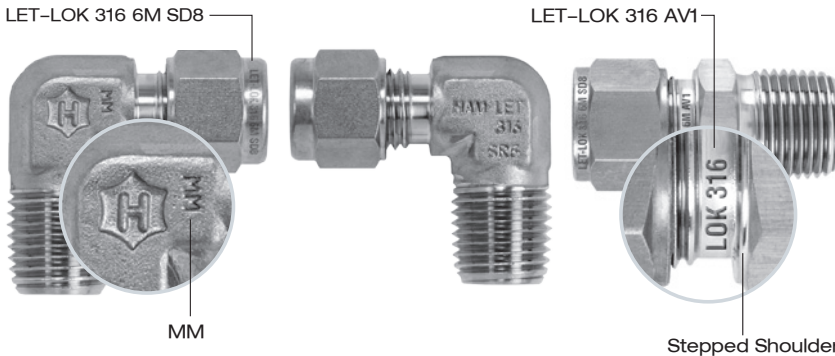

Fig. 1
Back side

Fig. 1
Front side

Fig. 2
Stepped Shoulder

⁽¹⁾ Tube O.D. ⁽²⁾ Material Batch

LET-LOK® INCH FITTINGS:

Tee & Elbow: (See Fig. 3)
Straight Fittings: (see Fig. 4)
Body: Shoulder marked:
 LET-LOK 316 AV2⁽²⁾
Nut: (See Fig. 3 & 4): Shoulder marked
 LET-LOK 316 1/2⁽¹⁾ BU2⁽²⁾



Fig. 3
Back side

Fig. 3
Front side

Fig. 4

⁽¹⁾ Tube O.D. ⁽²⁾ Material Batch

TUBING DATA FOR LET-LOK® FITTINGS

In order to assure maximum fitting reliability and performance, great care should be given when selecting the tubing for each application.

TUBE SELECTION

Four variables must be considered when ordering tube for use with LET-LOK® fittings:

1. Material
2. Tube wall thickness
3. Tube surface finish
4. Tube hardness

Tubing should comply with standard ASTM A213 or ASTM A269, be seamless, and fully annealed.

The tube must be free of scratches and suitable for bending and flaring.

TUBE OD TOLERANCES

1/16" – 1/8"	} ±	0.003"
2mm – 3 mm		0.076 mm
3/16" – 1 1/4"	} ±	0.005"
4mm – 25 mm		0.127 mm
1 1/2" – 2"	} ±	0.006"
38mm – 50 mm		0.152 mm

Ovality of twice OD tolerance is not suitable for LET-LOK fittings. The tube must be reasonably round.

The ends of the tube must be free of burrs.

Tubing hardness: The hardness of the tube must be lower than the hardness of the fitting material.

The hardness must not exceed Rockwell 90 HRB (200HV).

HIGH SAFETY

In applications where severe conditions and high pressure exist, we recommend the following installation procedures:

1. Check that the nut is finger tight.
2. Insert the tube (up to the shoulder).
3. Rotate the nut with a wrench until the tube does not rotate freely.
4. Mark position of the nut.
5. Rotate the nut 1-1/4 turns.

This method ensures that even if the tube O.D. is at the minimum tolerance, the ferrules will be in contact with the tube for the full 1-1/4 rotation.

TUBING DATA

TABLE 1: STAINLESS STEEL INCH TUBING

Tubing O.D.	WALL THICKNESS OF TUBE IN INCH																			
inch	0.010	0.012	0.014	0.016	0.020	0.028	0.035	0.049	0.065	0.083	0.095	0.109	0.120	0.134	0.156	0.188				
1/16	5600	6860	8150	9480	12080															
1/8						8550	10950													
3/16						5500	7100	10300												
1/4						4100	5200	7600	10300											
5/16							4100	5900	8100											
3/8								3350	4850	6550										
1/2									2650	3750	5150	6750								
5/8										2950	4050	5250	6050							
3/4											2450	3350	4250	4950	5850					
7/8												2050	2850	3650	4250	4850				
1													2400	3100	3600	4200	4700			
1 1/4														2400	2800	3300	3600	4100	4900	
1 1/2															2300	2700	3000	3400	4000	4900
2																2000	2200	2500	2900	3600

Annealed 304 or 316 stainless steel tubing complying with ASTM A213, A269 or equivalent specifications. For metal temp. from -20°F - 100°F (-29°C - 37°C). Suggested ordering information: Fully annealed high quality (Type 304 or 316) stainless steel hydraulic tubing ASTM A269 or A213 or equivalent, seamless or welded and drawn with a hardness of 90HRB (200HV) or less. Tubing should be without scratches and suitable for flaring and bending.

TABLE 2: STAINLESS STEEL METRIC TUBING

Tubing O.D.	WALL THICKNESS OF TUBE IN MM														
mm	0.8	1.0	1.2	1.5	1.8	2.0	2.2	2.5	2.8	3.0	3.5	4.0	4.5	5.0	
3	670														
6	310	420	540	710											
8		310	390	520											
10		240	300	400	510	580									
12		200	250	330	410	470									
14		160	200	270	340	380	430								
15		150	190	250	310	360	400								
16			170	230	290	330	370	400							
18			150	200	260	290	320	370							
20			140	180	230	260	290	330	380						
22			120	160	200	230	260	300	340						
25					180	200	230	260	290	320					
38							140	160	190	200	240	270	310		
50											150	180	210	240	270

Annealed 304 or 316 stainless steel tubing complying with ASTM A213, A269 or equivalent specifications. For metal temp. from -20°F - 100°F (-29°C - 37°C). Suggested ordering information: Fully annealed high quality (Type 304 or 316) stainless steel hydraulic tubing ASTM A269 or A213 or equivalent, seamless or welded and drawn with a hardness of 90HRB (200HV) or less. Tubing should be without scratches and suitable for flaring and bending.

WARNING! For Your Safety The system designer and user have the sole responsibility to select products suitable for their special application requirements and to ensure the proper installation, operation and maintenance of the product. Please consider application details, material compatibility and product ratings when making your selection. Improper selection or use of products can cause property damage or personal injury.

TUBING DATA

TABLE 3: COPPER TUBING WALL THICKNESS OF TUBE IN INCHES

Tubing O.D.		0.028	0.035	0.049	0.065	0.083	0.095	0.109	0.120
mm	inch								
2	1/8	2700	3600						
3	3/16	1800	2300	3400					
6	1/4	1300	1600	2500	3500				
8	5/16		1300	1900	2700				
10	3/8		1000	1600	2200				
12	1/2		800	1100	1600	2100			
16	5/8			900	1200	1600	1900		
20	3/4			700	1000	1300	1500	1800	
22	7/8			600	800	1100	1300	1500	
25	1			500	700	900	1100	1300	1500

Annealed copper seamless tubing complying with ASTM B68 and ASTM B75 specified in temper designation 060. Based on ultimate tensile strength of 30,000 psi (2067 bar). For metal temperatures from -20°C to 37°C). Suggested ordering information: High quality soft annealed seamless copper tubing ASTM B75 or equivalent.

TABLE 4: FACTORS USED TO DETERMINE ALLOWABLE PRESSURE AT HIGHER TEMPERATURES

°F	°C	A.I.S.I. 316	Copper
200	93	1	0.80
400	204	0.96	0.50
600	316	0.85	-
800	427	0.79	-
1000	538	0.76	-
1200	649	0.37	-

To determine allowable pressure at higher temperatures, multiply allowable working pressure from Tables 1 & 2 & 3 by factor shown in Table 4.

For example: The allowable pressure for Type 316 stainless steel, size 1/2" OD x .049" wall at 800°F(427°C) would be equivalent to 3750 psi x 0.79 = 2962.5 psi.

TABLE 5: GAS APPLICATION TUBING

INCH		METRIC	
Tubing O.D.	Min. Nominal Wall Thickness	Tubing O.D.	Min. Nominal Wall Thickness
1/8"	0.028"	3 mm	0.8 mm
3/16"	0.028"	6 mm	0.8 mm
1/4"	0.028"	8 mm	1.0 mm
5/16"	0.035"	10 mm	1.0 mm
3/8"	0.035"	12 mm	1.0 mm
1/2"	0.049"	14 mm	1.2 mm
5/8"	0.065"	16 mm	1.5 mm
3/4"	0.065"	18 mm	1.5 mm
7/8"	0.083"	20 mm	1.8 mm
1"	0.083"	22 mm	2.0 mm
1 1/4"	0.109"	25 mm	2.2 mm
1 1/2"	0.134"	38 mm	3.5 mm
2"	0.188"	50 mm	5.0 mm

Gases are characterized by small molecules, which can escape through the smallest leak path. For gas applications, we recommend to select tubing with greater wall thickness. Table 5 shows the recommended wall thicknesses for greater safety and efficiency.

WARNING! For Your Safety The system designer and user have the sole responsibility to select products suitable for their special application requirements and to ensure the proper installation, operation and maintenance of the product. Please consider application details, material compatibility and product ratings when making your selection. Improper selection or use of products can cause property damage or personal injury.

PRESSURE RATINGS

Pressure Ratings for HAM-LET Tube Fittings

To ensure leak-tight systems, it is important to carefully select high-quality tubing (see page 11 - Allowable working pressure).

Pipe End Thread (NPT and ISO 7) Pressure Ratings

Allowable pressure for male and female tapered pipe thread ends, Stainless Steel 316 and Brass.

TABLE 6: PRESSURE RATINGS

NPT / ISO Pipe Size	Stainless Steel 316		Brass	
	Male	Female	Male	Female
inch	psi			
1/16	11000	6700	5500	3300
1/8	10000	6500	5000	3200
1/4	8000	6600	4000	3300
3/8	7800	5300	3900	2600
1/2	7700	4900	3800	2400
3/4	7300	4600	3600	2300
1	5300	4400	2600	2200
1 1/4	6000	5000	3000	2500
1 1/2	5000	4600	2500	2300
2	3900	3900	1900	1900

Note: If pressure on LET-LOK end is higher than the pipe side, then pipe side needs heavier wall thickness of tapered pipe thread side.

Pressure Ratings for End Fittings per SAE J1926 (LOB) Surrounding Temperature

Pressure ratings are based on SAE J1926 at surrounding temperature.

TABLE 7: PRESSURE RATINGS

(LOB) SAE J1926 Thread Size	Stainless Steel 316	
	Nonpositionable	Positionable
inch	psi	
5/16 - 24	4568	4568
7/16 - 20	4568	4568
1/2 - 20	4568	4568
9/16 - 18	4568	3626
3/4 - 16	4568	3626
7/8 - 14	3626	2900
1 1/16 - 12	3626	2900
1 3/16 - 12	2900	2320
1 5/16 - 12	2900	2320
1 5/8 - 12	2320	1813
1 7/8 - 12	2320	1813
2 1/2 - 12	1813	1450

Note: 37° FLARE (AN) and LO ends can have lower pressure

O-Seal Pressure Ratings (page 45)

Stainless steel 316 O-seal fittings up to 1" and 25 mm are rated to 3000 psi.





































Positionable, ISO/BSP Parallel Thread (G) Pressure Ratings

Pressure ratings are at surrounding temperature.

TABLE 8: PRESSURE RATINGS

(G) ISO / BSPP Male Pipe size	Stainless Steel 316
inch	psi
1/8	4568
1/4	4568
3/8	4568
1/2	2320

LET-LOK INDEX

BACK FERRULE 760 LB	16		FEMALE CONNECTOR 766 LG	30		TUBE SOCKET WELD UNION 768 LW	48	
FRONT FERRULE 760 LF	16		REDUCER 767 LT	31		MALE ELBOW 769 L	49	
TUBE INSERT 760 LI	17		REDUCING PORT CONNECTOR 767 LM	34		MALE ELBOW 769 LR	51	
NUT 761 L	17		PORT CONNECTOR 767 LP	35		MALE PIPE WELD ELBOW 769 LN	52	
UNION 762 L	18		MALE CONNECTOR 768 L	36		SOCKET WELD ELBOW 769 LW	53	
REDUCING UNION 763 L	19		MALE CONNECTOR 768 LR	39		REDUCING ELBOW 769 LT	53	
UNION TEE 764 L	21		MALE CONNECTOR 768 LG	41		FEMALE ELBOW 770 L	54	
REDUCING TEE 764 LR	22		MALE CONNECTOR 768 LOK	43		MALE RUN TEE 771 L	55	
UNION ELBOW 765 L	24		MALE CONNECTOR 768 LOB	44		FEMALE RUN TEE 771 LF	56	
REDUCING UNION ELBOW 765 LR	25		MALE CONNECTOR 768 LOP	46		MALE BRANCH TEE 772 L	57	
FEMALE CONNECTOR 766 L	26		MALE CONNECTOR 768 LO	46		FEMALE BRANCH TEE 772 LF	58	
FEMALE CONNECTOR 766 LR	28		MALE PIPE WELD CONNECTOR 768 LN	47		BULKHEAD UNION 774 L	59	

A

B

C























D

E

F

G

H

BULKHEAD FEMALE CONNECTOR 774 LF	60		MALE ADAPTER TUBE TO PIPE 739 LMR	70		UNION 962 L	75	
BULKHEAD REDUCER 774 LT	60		WELD ADAPTER TUBE TO PIPE 739 LN	71		REDUCING UNION 963 L	75	
BULKHEAD MALE CONNECTOR 774 LM	61		SOCKET WELD ADAPTER 739 LW	71		UNION TEE 964 L	75	
BULKHEAD REDUCING UNION 775 L	62		MALE ADAPTER 739 LMOB	72		POSITIONABLES	76	
UNION CROSS 7102 L	63		LET-LOK TO AN ADAPTER 761 LFL	73		UNION DIELECTRIC 762 L Dielectric	83	
CAP 7108 L	64		LET-LOK TO AN UNION 762 LFL	73		ALLOY 400 CONNECTOR	85	
PLUG 7121 L	65		LET-LOK TO AN BULKHEAD UNION 774 LFL	73		ALLOY C-276 CONNECTOR	87	
FEMALE ADAPTER TUBE TO PIPE 739 LF	66		MALE ADAPTER TUBE TO AN 739 LTFL	74		ACCESSORIES	89	
MALE ADAPTER TUBE TO PIPE 739 LM	68		MALE NUT 961 L	75		STOP COLLAR	92	

LET-LOK® MATERIAL DESCRIPTION

EXAMPLE:

768L

Material Description

SS - Stainless Steel 316
 B - Brass
 M - Monel 400
 HC - Hastelloy C-276

1/4

X

1/4

All orders should include material description and ordering information (See product table).

760 LB BACK FERRULE

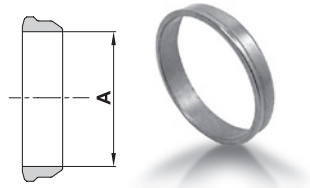

760 LF FRONT FERRULE

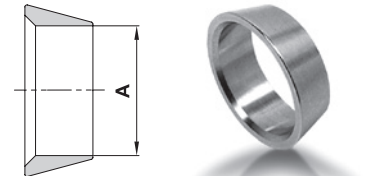

METRIC		INCH		
Ordering Information	A Tube O.D.	Ordering Information	A Tube O.D.	
	mm		inch	mm
760LB _ 2	2	760LB _ 1/16	1/16	1.58
760LB _ 3	3	760LB _ 1/8	1/8	3.17
760LB _ 4	4	760LB _ 3/16	3/16	4.76
760LB _ 6	6	760LB _ 1/4	1/4	6.35
760LB _ 8	8	760LB _ 5/16	5/16	7.93
760LB _ 10	10	760LB _ 3/8	3/8	9.52
760LB _ 12	12	760LB _ 1/2	1/2	12.70
760LB _ 14	14	760LB _ 5/8	5/8	15.87
760LB _ 15	15	760LB _ 3/4	3/4	19.05
760LB _ 16	16	760LB _ 7/8	7/8	22.22
760LB _ 18	18	760LB _ 1	1	25.40
760LB _ 20	20	760LB _ 1 1/4 *	1 1/4	31.75
760LB _ 22	22	760LB _ 1 1/2 *	1 1/2	38.10
760LB _ 25	25	760LB _ 2 *	2	50.80
760LB _ 38 *	38			
760LB _ 50 *	50			

METRIC		INCH		
Ordering Information	A Tube O.D.	Ordering Information	A Tube O.D.	
	mm		inch	mm
760LF _ 2	2	760LF _ 1/16	1/16	1.58
760LF _ 3	3	760LF _ 1/8	1/8	3.17
760LF _ 4	4	760LF _ 3/16	3/16	4.76
760LF _ 6	6	760LF _ 1/4	1/4	6.35
760LF _ 8	8	760LF _ 5/16	5/16	7.93
760LF _ 10	10	760LF _ 3/8	3/8	9.52
760LF _ 12	12	760LF _ 1/2	1/2	12.70
760LF _ 14	14	760LF _ 5/8	5/8	15.87
760LF _ 15	15	760LF _ 3/4	3/4	19.05
760LF _ 16	16	760LF _ 7/8	7/8	22.22
760LF _ 18	18	760LF _ 1	1	25.40
760LF _ 20	20	760LF _ 1 1/4 *	1 1/4	31.75
760LF _ 22	22	760LF _ 1 1/2 *	1 1/2	38.10
760LF _ 25	25	760LF _ 2 *	2	50.80
760LF _ 38 *	38			
760LF _ 50 *	50			

*Without Ferrule Set.

*Without Ferrule Set.

FERRULE SETS

All LET-LOK Ferrules are available as sets. Ferrule sets simplify stocking and assembly. Ferrule sets prevent damage of single ferrules during shipping.

The back and front ferrules are arranged as pairs in the set; ready for easy assembly.

Note: Can be supplied also with Nuts.
Example: 760LNS SS 1/4

ORDERING INFORMATION FOR FERRULE SETS

EXAMPLE: **760LS**

SS

1/4

SS = Stainless Steel 316
B = Brass
M = Monel 400
HC = Hastelloy C-276
T = Teflon

Ferrules Material

Tube O.D.

The O.D. size is always the first to be described

Dimensions are for reference only, and are subject to change without notice.

760 LI TUBE INSERT

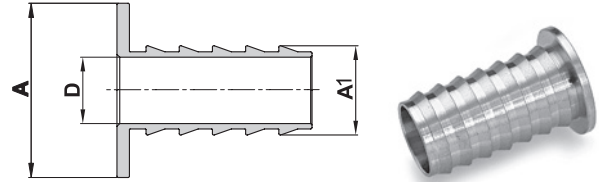

METRIC			
Ordering Information	A	A1	D
	Tube O.D.	Tube I.D.	
	mm	mm	mm
760LI _ 6 X 4	6	4	2.8
760LI _ 8 X 6	8	6	4.4
760LI _ 10 X 8	10	8	6.4
760LI _ 12 X 8	12	8	6.4
760LI _ 12 X 10	12	10	8.3

INCH						
Ordering Information	A		A1		D	
	Tube O.D.		Tube I.D.			
	inch	mm	inch	mm	inch	mm
760LI _ 3/16 X 1/8	3/16	4.76	1/8	3.17	.09	2.30
760LI _ 1/4 X 1/8	1/4	6.35	1/8	3.17	.09	2.30
760LI _ 1/4 X 0.17	1/4	6.35	.17	4.32	.11	2.70
760LI _ 1/4 X 3/16	1/4	6.35	3/16	4.76	.12	3.10
760LI _ 5/16 X 1/8	5/16	7.93	1/8	3.17	.09	2.30
760LI _ 5/16 X 3/16	5/16	7.93	3/16	4.76	.12	3.00
760LI _ 5/16 X 1/4	5/16	7.93	1/4	6.35	.18	4.65
760LI _ 3/8 X 3/16	3/8	9.52	3/16	4.76	.12	3.10
760LI _ 3/8 X 1/4	3/8	9.52	1/4	6.35	.18	4.65
760LI _ 1/2 X 1/4	1/2	12.70	1/4	6.35	.18	4.65
760LI _ 1/2 X 3/8	1/2	12.70	3/8	9.52	.31	7.80
760LI _ 5/8 X 3/8	5/8	15.87	3/8	9.52	.31	7.80
760LI _ 5/8 X 1/2	5/8	15.87	1/2	12.70	.44	11.10
760LI _ 3/4 X 1/2	3/4	19.05	1/2	12.70	.44	11.10
760LI _ 3/4 X 5/8	3/4	19.05	5/8	15.87	.56	14.20
760LI _ 1 X 3/4	1	25.40	3/4	19.05	.69	17.50

761 L NUT

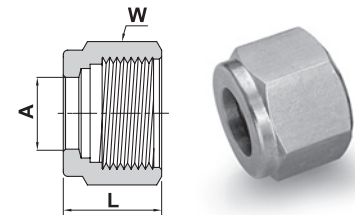

METRIC			
Ordering Information	A	W	L
	Tube O.D.	Hex. Flat	
	mm	mm	mm
761L _ 2	2	12	11.9
761L _ 3	3	12	11.9
761L _ 4	4	12	11.9
761L _ 6	6	14	12.7
761L _ 8	8	16	13.5
761L _ 10	10	19	15.1
761L _ 12	12	22	17.4
761L _ 14	14	25	17.4
761L _ 15	15	25	17.4
761L _ 16	16	25	17.4
761L _ 18	18	30	17.4
761L _ 20	20	32	17.4
761L _ 22	22	32	17.4
761L _ 25	25	38	20.6
761L _ 38	38	60	40.6
761L _ 50	50	3 inch	54.0

INCH				
Ordering Information	A		W	L
	Tube O.D.		Hex. Flat	
	inch	mm	inch	inch
761L _ 1/16	1/16	1.58	5/16	.31
761L _ 1/8	1/8	3.17	7/16	.47
761L _ 3/16	3/16	4.76	1/2	.47
761L _ 1/4	1/4	6.35	9/16	.50
761L _ 5/16	5/16	7.93	5/8	.53
761L _ 3/8	3/8	9.52	11/16	.56
761L _ 1/2	1/2	12.70	7/8	.69
761L _ 5/8	5/8	15.87	1	.69
761L _ 3/4	3/4	19.05	1 1/8	.69
761L _ 7/8	7/8	22.22	1 1/4	.69
761L _ 1	1	25.40	1 1/2	.81
761L _ 1 1/4	1 1/4	31.75	1 7/8	1.25
761L _ 1 1/2	1 1/2	38.10	2 1/4	1.50
761L _ 2	2	50.80	3	2.06

"D" - Dimension is minimum opening. Dimensions are for reference only, and are subject to change without notice.

762 L UNION

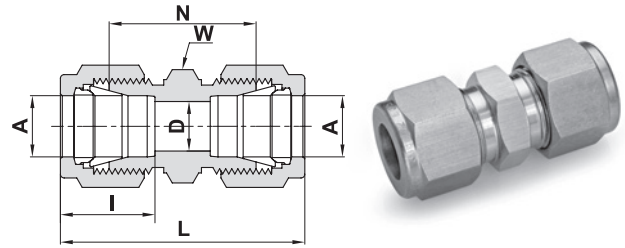

TUBE (METRIC) TO TUBE (METRIC)

Ordering Information	A Tube O.D.		D		W Hex. Flat	N		L		I	
	mm	mm	mm	mm	mm	mm	mm	mm	mm	mm	mm
762L _ 2	2	1.7			12		22.4		35.6		12.9
762L _ 3	3	2.4			12		22.1		35.3		12.9
762L _ 4	4	2.4			12		24.1		37.3		13.7
762L _ 6	6	4.8			14		26.2		41.0		15.3
762L _ 8	8	6.4			15		28.2		43.2		16.2
762L _ 10	10	7.9			18		31.0		46.2		17.2
762L _ 12	12	9.5			22		31.0		51.2		22.8
762L _ 14	14	11.1			24		31.8		52.0		24.4
762L _ 15	15	11.9			24		31.8		52.0		24.4
762L _ 16	16	12.7			24		31.8		52.0		24.4
762L _ 18	18	15.1			27		33.3		53.5		24.4
762L _ 20	20	15.9			30		34.8		55.0		26.0
762L _ 22	22	18.3			30		34.8		55.0		26.0
762L _ 25	25	21.8			35		40.4		65.0		31.3
762L _ 38	*38	33.7			55		58.4		114.0		49.4
762L _ 50	*50	45.2			3 inch		71.7		146.0		65.0

TUBE (INCH) TO TUBE (INCH)

Ordering Information	A Tube O.D.		D		W Hex. Flat	N		L		I	
	inch	mm	inch	mm	inch	inch	mm	inch	mm	inch	mm
762L _ 1/16	1/16	1.58	.05	1.27	5/16	.69	17.52	.99	25.14	.34	8.6
762L _ 1/8	1/8	3.17	.09	2.28	7/16	.88	22.35	1.40	35.56	.50	12.7
762L _ 3/16	3/16	4.76	.12	3.04	7/16	.95	24.13	1.47	37.33	.54	13.7
762L _ 1/4	1/4	6.35	.19	4.82	1/2	1.03	26.16	1.61	40.89	.60	15.2
762L _ 5/16	5/16	7.93	.25	6.35	9/16	1.11	28.19	1.69	42.92	.64	16.2
762L _ 3/8	3/8	9.52	.28	7.11	5/8	1.19	30.22	1.77	44.95	.66	16.8
762L _ 1/2	1/2	12.70	.41	10.41	13/16	1.22	30.98	2.02	51.30	.90	22.9
762L _ 5/8	5/8	15.87	.50	12.70	15/16	1.25	31.75	2.05	52.07	.96	24.4
762L _ 3/4	3/4	19.05	.62	15.75	1 1/16	1.31	33.27	2.11	53.59	.96	24.4
762L _ 7/8	7/8	22.22	.72	18.28	1 3/16	1.37	34.80	2.17	55.11	1.02	25.9
762L _ 1	1	25.40	.88	22.35	1 3/8	1.59	40.38	2.55	64.77	1.23	31.2
762L _ 1 1/4	*1 1/4	31.75	1.09	27.70	1 3/4	1.89	48.00	3.63	92.20	1.62	41.2
762L _ 1 1/2	*1 1/2	38.10	1.34	34.00	2 1/8	2.11	53.60	4.25	107.95	1.97	50.0
762L _ 2	*2	50.80	1.81	45.97	2 3/4	2.94	74.67	5.88	149.35	2.66	67.6

* Including low friction paste, See page 89

"D" - Dimension is minimum opening. Dimensions are for reference only, and are subject to change without notice.

763 L REDUCING UNION

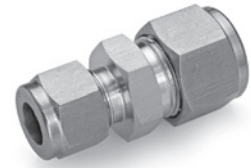
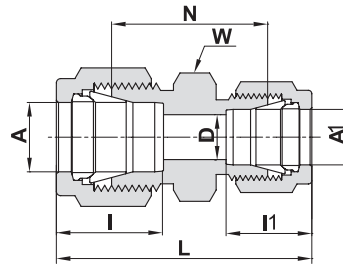

TUBE (METRIC) TO TUBE (METRIC)

Ordering Information	A	A1	D	W	N	L	I	I1
	Tube O.D.	Tube O.D.						
	mm	mm	mm	mm	mm	mm	mm	mm
763L _ 3 X 2	3	2	1.7	12	22.1	35.3	12.9	12.9
763L _ 6 X 2	6	2	1.7	14	24.6	38.6	15.3	12.9
763L _ 6 X 3	6	3	2.4	14	24.6	38.6	15.3	12.9
763L _ 6 X 4	6	4	2.4	14	25.4	39.4	15.3	13.7
763L _ 8 X 6	8	6	4.8	15	27.4	42.3	16.2	15.3
763L _ 10 X 6	10	6	4.8	18	29.5	44.5	17.2	15.3
763L _ 10 X 8	10	8	6.4	18	30.0	45.1	17.2	16.2
763L _ 12 X 6	12	6	4.8	22	29.5	47.0	22.8	15.3
763L _ 12 X 8	12	8	6.4	22	30.2	47.8	22.8	16.2
763L _ 12 X 10	12	10	7.9	22	31.0	48.7	22.8	17.2
763L _ 16 X 10	16	10	7.9	24	31.8	49.5	24.4	17.2
763L _ 16 X 12	16	12	9.5	24	31.8	52.0	24.4	22.8
763L _ 18 X 12	18	12	9.5	27	33.3	53.5	24.4	22.8
763L _ 25 X 18	25	18	15.1	35	38.6	61.0	31.3	24.4
763L _ 25 X 20	25	20	15.9	35	39.9	62.3	31.3	26.0
763L _ 38 X 20	*38	20	15.9	55	49.8	87.5	49.4	26.0
763L _ 38 X 25	*38	25	21.8	55	55.5	95.4	49.4	31.3

TUBE (METRIC) TO TUBE (INCH)

Ordering Information	A	A1	D	W	N	L	I	I1
	Tube O.D.	Tube O.D.						
	mm	inch	mm	mm	mm	mm	mm	mm
763L _ 2 X 1/4	2	1/4	1.7	14	24.0	38.6	12.9	15.2
763L _ 3 X 1/8	3	1/8	2.4	12	22.1	35.2	12.9	12.7
763L _ 4 X 1/8	4	1/8	2.4	12	23.4	36.5	13.7	12.7
763L _ 4 X 1/4	4	1/4	2.4	14	25.4	39.4	13.7	15.2
763L _ 6 X 1/8	6	1/8	2.4	14	24.6	38.5	15.3	12.7
763L _ 6 X 1/4	6	1/4	4.8	14	26.2	41.0	15.3	15.2
763L _ 6 X 5/16	6	5/16	4.8	14	27.4	42.3	15.3	16.2
763L _ 8 X 1/8	8	1/8	2.4	15	25.7	39.8	16.2	12.7
763L _ 8 X 1/4	8	1/4	4.8	15	27.4	42.3	16.2	15.2
763L _ 8 X 3/8	8	3/8	6.4	16	29.5	44.3	16.2	16.8
763L _ 10 X 1/8	10	1/8	2.4	18	27.7	41.8	17.2	12.7
763L _ 10 X 1/4	10	1/4	4.8	18	29.5	44.5	17.2	15.2
763L _ 10 X 5/16	10	5/16	6.4	18	30.0	45.1	17.2	16.2
763L _ 10 X 3/8	10	3/8	7.1	18	31.0	45.9	17.2	16.8
763L _ 12 X 5/16	12	5/16	6.4	22	30.2	47.8	22.8	16.2
763L _ 12 X 3/8	12	3/8	7.1	22	31.0	48.4	22.8	16.8
763L _ 12 X 1/2	12	1/2	9.5	22	31.0	51.2	22.8	22.9
763L _ 15 X 1/2	15	1/2	10.3	24	31.8	52.0	24.4	22.9
763L _ 16 X 5/8	16	5/8	12.7	24	31.8	52.0	24.4	24.4
763L _ 18 X 3/4	18	3/4	15.1	27	33.3	53.5	24.4	24.4

* Including low friction paste, See page 89 "D" - Dimension is minimum opening. Dimensions are for reference only, and are subject to change without notice.

Cont'd next page

763 L
REDUCING UNION (Cont'd)

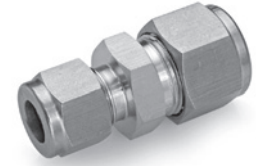
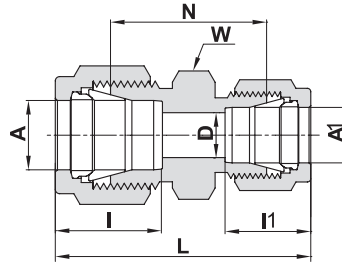

TUBE (INCH) TO TUBE (INCH)

Ordering Information	A Tube O.D.		A1 Tube O.D.		D		W Hex. Flat	N		L		I		I1	
	inch	mm	inch	mm	inch	mm	inch	inch	mm	inch	mm	inch	mm	inch	mm
763L_ 1/8 X 1/16	1/8	3.17	1/16	1.58	.05	1.27	7/16	.81	20.57	1.22	30.98	.50	12.7	.34	8.6
763L_ 3/16 X 1/16	3/16	4.76	1/16	1.58	.05	1.27	7/16	.86	21.84	1.27	32.26	.54	13.7	.34	8.6
763L_ 3/16 X 1/8	3/16	4.76	1/8	3.17	.09	2.28	7/16	.92	23.36	1.44	36.57	.54	13.7	.50	12.7
763L_ 1/4 X 1/16	1/4	6.35	1/16	1.58	.05	1.27	1/2	.91	23.11	1.35	34.29	.60	15.2	.34	8.6
763L_ 1/4 X 1/8	1/4	6.35	1/8	3.17	.09	2.28	1/2	.97	24.63	1.52	38.60	.60	15.2	.50	12.7
763L_ 1/4 X 3/16	1/4	6.35	3/16	4.76	.12	3.04	1/2	1.00	25.40	1.55	37.37	.60	15.2	.54	13.7
763L_ 5/16 X 1/8	5/16	7.93	1/8	3.17	.09	2.28	9/16	1.01	25.65	1.56	39.62	.64	16.2	.50	12.7
763L_ 5/16 X 1/4	5/16	7.93	1/4	6.35	.19	4.82	9/16	1.08	27.43	1.66	42.16	.64	16.2	.60	15.2
763L_ 3/8 X 1/16	3/8	9.52	1/16	1.58	.05	1.27	5/8	1.00	25.40	1.44	36.58	.66	16.8	.34	8.6
763L_ 3/8 X 1/8	3/8	9.52	1/8	3.17	.09	2.28	5/8	1.06	26.92	1.61	40.89	.66	16.8	.50	12.7
763L_ 3/8 X 1/4	3/8	9.52	1/4	6.35	.19	4.82	5/8	1.12	28.44	1.70	43.18	.66	16.8	.60	15.2
763L_ 3/8 X 5/16	3/8	9.52	5/16	7.93	.25	6.35	5/8	1.16	29.46	1.74	44.19	.66	16.8	.64	16.2
763L_ 1/2 X 1/8	1/2	12.70	1/8	3.17	.09	2.28	13/16	1.12	28.44	1.78	45.21	.90	22.9	.50	12.7
763L_ 1/2 X 1/4	1/2	12.70	1/4	6.35	.19	4.82	13/16	1.16	29.46	1.85	46.99	.90	22.9	.60	15.2
763L_ 1/2 X 3/8	1/2	12.70	3/8	9.52	.28	7.11	13/16	1.22	30.98	1.91	48.51	.90	22.9	.66	16.8
763L_ 5/8 X 3/8	5/8	15.87	3/8	9.52	.28	7.11	15/16	1.25	31.75	1.94	49.27	.96	24.4	.66	16.8
763L_ 5/8 X 1/2	5/8	15.87	1/2	12.70	.41	10.41	15/16	1.25	31.75	2.05	52.07	.96	24.4	.90	22.9
763L_ 3/4 X 1/4	3/4	19.05	1/4	6.35	.19	4.82	1 1/16	1.25	31.75	1.94	49.28	.96	24.4	.60	15.2
763L_ 3/4 X 3/8	3/4	19.05	3/8	9.52	.28	7.11	1 1/16	1.31	33.27	2.00	50.80	.96	24.4	.66	16.8
763L_ 3/4 X 1/2	3/4	19.05	1/2	12.70	.41	10.41	1 1/16	1.31	33.27	2.11	53.59	.96	24.4	.90	22.9
763L_ 3/4 X 5/8	3/4	19.05	5/8	15.87	.50	12.70	1 1/16	1.31	33.27	2.11	53.59	.96	24.4	.96	24.4
763L_ 1 X 1/2	1	25.4	1/2	12.70	.41	10.41	1 3/8	1.50	38.10	2.38	60.45	1.23	31.2	.90	22.9
763L_ 1 X 3/4	1	25.4	3/4	19.05	.62	15.75	1 3/8	1.50	38.10	2.38	60.45	1.23	31.2	.96	24.4

764 L UNION TEE

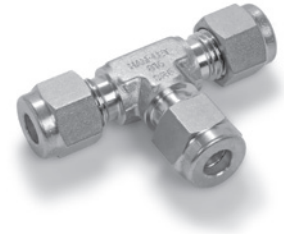
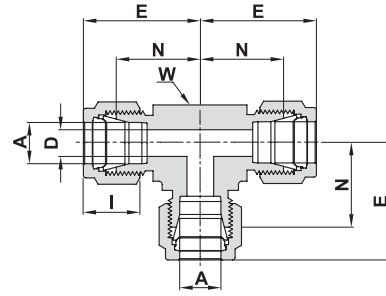

ALL TUBE (METRIC)

Ordering Information	A Tube O.D.		D		W Wrench Flat		N		E		I	
	mm	mm	mm	mm	inch	mm	mm	mm	mm	mm	mm	mm
764L _ 2	2		1.7		3/8	9.5	15.7		22.3		12.9	
764L _ 3	3		2.4		3/8	9.5	15.7		22.3		12.9	
764L _ 4	4		2.4		1/2	12.7	18.8		25.4		13.7	
764L _ 6	6		4.8		1/2	12.7	19.6		27.0		15.3	
764L _ 8	8		6.4		5/8	15.9	22.4		29.9		16.2	
764L _ 10	10		7.9		11/16	17.5	23.9		31.5		17.2	
764L _ 12	12		9.5		13/16	20.6	25.9		36.0		22.8	
764L _ 14	14		11.1		15/16	23.8	28.7		38.8		24.4	
764L _ 15	15		11.9		15/16	23.8	28.7		38.8		24.4	
764L _ 16	16		12.7		15/16	23.8	28.7		38.8		24.4	
764L _ 18	18		15.1		1 1/8	28.6	29.7		39.8		24.4	
764L _ 20	20		15.9		1 3/8	34.9	34.5		44.6		26.0	
764L _ 22	22		18.3		1 3/8	34.9	34.5		44.6		26.0	
764L _ 25	25		21.8		1 3/8	34.9	36.8		49.1		31.3	
764L _ 38	*38		33.7		-	55.0	56.4		84.0		49.4	
764L _ 50	*50		45.2		2 3/4	69.9	68.9		106.0		65.0	

ALL TUBE (INCH)

Ordering Information	A Tube O.D.		D		W Wrench Flat		N		E		I	
	inch	mm	inch	mm	inch	mm	inch	mm	inch	mm	inch	mm
764L _ 1/16	1/16	1.58	.05	1.27	3/8	9.5	.55	14.00	.70	17.80	.34	8.6
764L _ 1/8	1/8	3.17	.09	2.28	3/8	9.5	.62	15.74	.88	22.35	.50	12.7
764L _ 3/16	3/16	4.76	.12	3.04	1/2	12.7	.70	17.80	.96	24.40	.54	13.7
764L _ 1/4	1/4	6.35	.19	4.82	1/2	12.7	.77	19.55	1.06	26.90	.60	15.2
764L _ 5/16	5/16	7.93	.25	6.35	5/8	15.9	.88	22.35	1.17	29.71	.64	16.2
764L _ 3/8	3/8	9.52	.28	7.11	5/8	15.9	.91	23.11	1.20	30.48	.66	16.8
764L _ 1/2	1/2	12.70	.41	10.41	13/16	20.6	1.02	25.90	1.42	36.06	.90	22.9
764L _ 5/8	5/8	15.87	.50	12.70	15/16	23.8	1.13	28.70	1.53	38.90	.96	24.4
764L _ 3/4	3/4	19.05	.62	15.74	1 1/8	28.6	1.17	29.70	1.57	39.90	.96	24.4
764L _ 7/8	7/8	22.22	.72	18.29	1 3/8	34.9	1.36	34.54	1.76	44.70	1.02	25.9
764L _ 1	1	25.40	.88	22.35	1 3/8	34.9	1.45	36.83	1.93	49.00	1.23	31.2
764L _ 1 1/4	*1 1/4	31.75	1.09	27.7	1 11/16	42.9	1.75	44.50	2.62	66.55	1.62	41.2
764L _ 1 1/2	*1 1/2	38.10	1.34	34.0	2	50.8	2.00	50.80	3.07	77.98	1.97	50.0
764L _ 2	*2	50.80	1.81	45.97	2 3/4	69.9	2.75	69.85	4.22	107.19	2.66	67.6

* Including low friction paste, See page 89

"D" - Dimension is minimum opening. Dimensions are for reference only, and are subject to change without notice.

764 LR REDUCING TEE

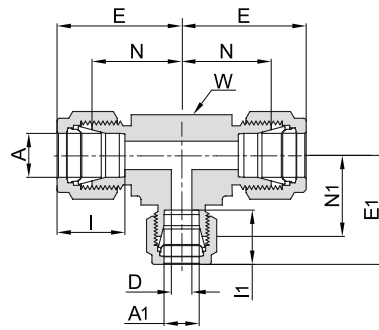
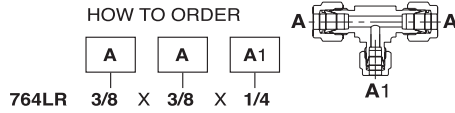

ALL TUBE (METRIC)

Ordering Information	A		A1		E		E1		I		I1		D		W		N		N1	
	Tube O.D.		Tube O.D.		mm		mm		mm		mm		mm		Wrench Flat		mm		mm	
	mm	mm	mm	mm	mm	mm	mm	mm	mm	mm	mm	mm	mm	mm	mm	mm	mm	mm	mm	mm
764LR_8MMX8MMX6MM	8	6	29.9	29.8	16.2	15.3	4.8	5/8	15.9	22.4	22.4									
764LR_10MMX10MMX6MM	10	6	31.5	31.3	17.2	15.3	4.8	11/16	17.5	23.9	23.9									
764LR_12MMX12MMX6MM	12	6	36.0	31.8	22.8	15.3	4.8	13/16	20.6	25.9	24.4									
764LR_12MMX12MMX10MM	12	10	36.0	33.5	22.8	17.2	7.9	13/16	20.6	25.9	25.9									
764LR_14MMX14MMX10MM	14	10	38.8	36.3	24.4	17.2	7.9	15/16	23.8	28.7	28.7									
764LR_18MMX18MMX12MM	18	12	39.8	39.8	24.4	22.8	9.5	1 1/8	28.6	29.7	29.7									
764LR_50MMX50MMX38MM	*50	*38	106.0	96.2	65.0	49.4	33.7	2 3/4	69.9	68.9	68.6									

ALL TUBE (INCH)

Ordering Information	A		A1		E		E1		I		I1		D		W		N		N1	
	Tube O.D.		Tube O.D.		inch		mm		inch		mm		inch		mm		inch		mm	
	inch	mm	inch	mm	inch	mm	inch	mm	inch	mm	inch	mm	inch	mm	inch	mm	inch	mm	inch	mm
764LR_1/4 X 1/4 X 1/8	1/4	6.35	1/8	3.17	1.06	26.9	1.03	26.2	.60	15.2	.50	12.7	.09	2.28	1/2	12.7	.77	19.6	.77	19.6
764LR_3/8 X 3/8 X 1/4	3/8	9.52	1/4	6.35	1.20	30.5	1.14	29.0	.66	16.8	.60	15.2	.19	4.82	5/8	15.9	.91	23.1	.85	21.6
764LR_1/2 X 1/2 X 1/4	1/2	12.70	1/4	6.35	1.42	36.1	1.25	31.8	.90	22.9	.60	15.2	.19	4.82	13/16	20.6	1.02	25.9	.96	24.4
764LR_1/2 X 1/2 X 3/8	1/2	12.70	3/8	9.52	1.42	36.1	1.31	33.3	.90	22.9	.66	16.8	.28	7.11	13/16	20.6	1.02	25.9	1.02	25.9
764LR_5/8 X 5/8 X 3/8	5/8	15.88	3/8	9.52	1.53	38.9	1.42	36.1	.96	24.4	.66	16.8	.28	7.11	15/16	23.8	1.13	28.7	1.13	28.7
764LR_3/4 X 3/4 X 1/4	3/4	19.05	1/4	6.35	1.57	39.9	1.46	37.1	.96	24.4	.60	15.2	.19	4.82	1 1/8	28.6	1.17	29.7	1.17	29.7
764LR_3/4 X 3/4 X 3/8	3/4	19.05	3/8	9.52	1.57	39.9	1.46	37.1	.96	24.4	.66	16.8	.28	7.11	1 1/8	28.6	1.17	29.7	1.17	29.7
764LR_3/4 X 3/4 X 1/2	3/4	19.05	1/2	12.70	1.57	39.9	1.57	39.9	.96	24.4	.90	22.9	.41	10.41	1 1/8	28.6	1.17	29.7	1.17	29.7
764LR_1 X 1 X 3/8	1	25.4	3/8	9.52	1.93	49.0	1.65	41.9	1.23	31.2	.66	16.8	.28	7.11	1 3/8	34.9	1.45	36.8	1.36	34.5
764LR_1 X 1 X 1/2	1	25.4	1/2	12.70	1.93	49.0	1.76	44.7	1.23	31.2	.90	22.9	.41	10.41	1 3/8	34.9	1.45	36.8	1.36	34.5
764LR_1 X 1 X 3/4	1	25.4	3/4	19.05	1.93	49.0	1.76	44.7	1.23	31.2	0.96	24.4	.62	15.75	1 3/8	34.9	1.45	36.8	1.36	34.5
764LR_1 1/4 X 1 1/4 X 1	*1 1/4	31.75	1	25.40	2.67	67.8	2.17	55.1	1.62	41.2	1.23	31.2	.88	22.35	1 11/16	42.9	1.75	44.5	1.69	42.9
764LR_1 1/2 X 1 1/2 X 1	*1 1/2	38.10	1	25.40	3.10	78.7	2.36	59.9	1.97	50.0	1.23	31.2	.88	22.35	2	50.8	2.00	50.8	1.88	47.8

* Including low friction paste, See page 89

"D" - Dimension is minimum opening. Dimensions are for reference only, and are subject to change without notice.

Cont'd next page

764 LR REDUCING TEE

(Cont'd)

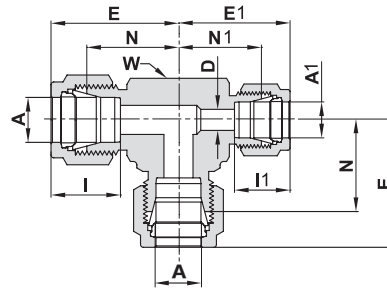
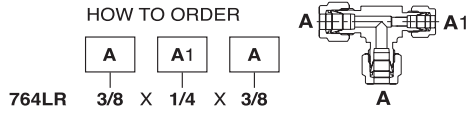

ALL TUBE (INCH)

Ordering Information	A Tube O.D.		A1 Tube O.D.		E		E1		I		I1		D		W Wrench Flat		N		N1	
	inch	mm	inch	mm	inch	mm	inch	mm	inch	mm	inch	mm	inch	mm	inch	mm	inch	mm	inch	mm
764LR_1/4 X 1/8 X 1/4	1/4	6.35	1/8	3.17	1.06	26.9	1.03	26.2	.60	15.2	.50	12.7	.09	2.28	1/2	12.7	.77	19.6	.77	19.6
764LR_3/8 X 1/4 X 3/8	3/8	9.25	1/4	6.35	1.20	30.5	1.14	29.0	.66	16.8	.60	15.2	.19	4.82	5/8	15.9	.91	23.1	.85	21.6
764LR_1/2 X 1/4 X 1/2	1/2	12.7	1/4	6.35	1.42	36.1	1.31	33.3	.90	22.9	.60	15.2	.19	4.82	13/16	20.6	1.02	25.9	1.02	25.9
764LR_1/2 X 3/8 X 1/2	1/2	12.7	3/8	9.52	1.42	36.1	1.31	33.3	.90	22.9	.66	16.8	.28	7.11	13/16	20.6	1.02	25.9	1.02	25.9
764LR_3/4 X 3/8 X 3/4	3/4	19.05	3/8	9.52	1.57	39.9	1.46	37.1	.96	24.4	.66	16.8	.28	7.11	1 1/8	28.6	1.17	29.7	1.17	29.7

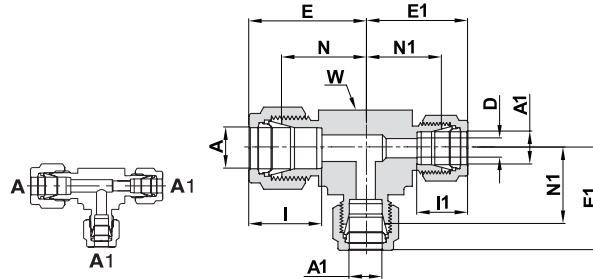
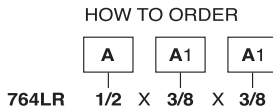

ALL TUBE (INCH)

Ordering Information	A Tube O.D.		A1 Tube O.D.		E		E1		I		I1		D		W Wrench Flat		N		N1	
	inch	mm	inch	mm	inch	mm	inch	mm	inch	mm	inch	mm	inch	mm	inch	mm	inch	mm	inch	mm
764LR_1/2 X 3/8 X 3/8	1/2	12.70	3/8	9.52	1.42	36.1	1.31	33.3	.90	22.9	.66	16.8	.28	7.1	13/16	20.6	1.02	25.9	1.02	25.9
764LR_5/8 X 3/8 X 3/8	5/8	15.87	3/8	9.52	1.53	38.9	1.42	36.1	.96	24.4	.66	16.8	.28	7.1	15/16	23.8	1.13	28.7	1.13	28.7
764LR_3/4 X 3/8 X 3/8	3/4	19.05	3/8	9.52	1.57	39.9	1.46	37.1	.96	24.4	.66	16.8	.28	7.1	1 1/8	28.6	1.17	29.7	1.17	29.7

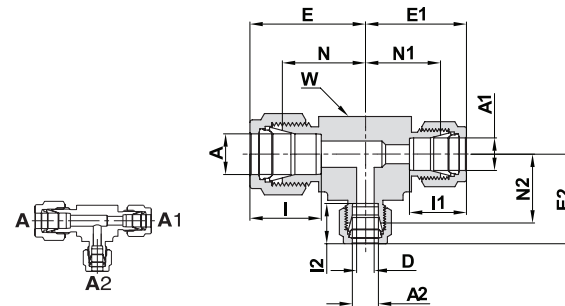
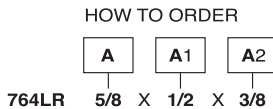

ALL TUBE (INCH)

Ordering Information	A Tube O.D.		A1 Tube O.D.		A2 Tube O.D.		E		E1		E2		I		I1		I2		D		W Wrench Flat		N		N1&N2	
	inch	mm	inch	mm	inch	mm	inch	mm	inch	mm	inch	mm	inch	mm	inch	mm	inch	mm	inch	mm	inch	mm	inch	mm	inch	mm
764LR_5/8 X 1/2 X 3/8	5/8	15.87	1/2	12.70	3/8	9.52	1.53	38.9	1.53	38.9	1.42	36.1	.96	24.4	.90	22.9	.66	16.8	.28	7.11	15/16	23.8	1.13	28.7	1.13	28.7
764LR_3/4 X 1/2 X 3/8	3/4	19.05	1/2	12.70	3/8	9.52	1.57	39.9	1.57	39.9	1.46	37.1	.96	24.4	.90	22.9	.66	16.8	.28	7.11	1 1/8	28.6	1.17	29.7	1.17	29.7
764LR_1 X 3/4 X 3/8	1	25.40	3/4	19.05	3/8	9.52	1.93	49.0	1.76	44.7	1.65	41.9	1.23	31.2	.96	24.4	.66	16.8	.28	7.11	1 3/8	34.9	1.45	36.8	1.36	34.5

"D" - Dimension is minimum opening. Dimensions are for reference only, and are subject to change without notice.

765 L UNION ELBOW

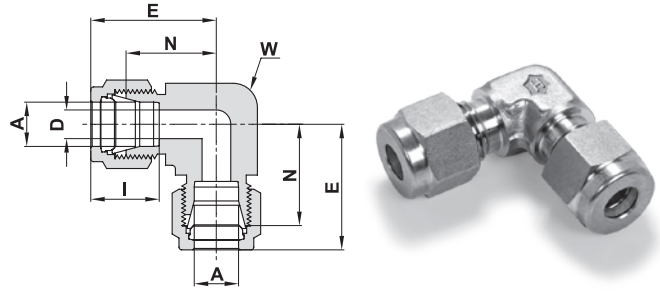

TUBE (METRIC) TO TUBE (METRIC)

Ordering Information	A Tube O.D.		D		W Wrench Flat		N		E		I	
	mm	mm	mm	mm	inch	mm	mm	mm	mm	mm	mm	mm
765L _ 3	3		2.4		3/8	9.5		15.7		22.3		12.9
765L _ 4	4		2.4		1/2	12.7		18.8		25.4		13.7
765L _ 6	6		4.8		1/2	12.7		19.6		27.0		15.3
765L _ 8	8		6.4		9/16	14.3		21.3		28.8		16.2
765L _ 10	10		7.9		11/16	17.5		23.9		31.5		17.2
765L _ 12	12		9.5		13/16	20.6		25.9		36.0		22.8
765L _ 14	14		11.1		15/16	23.8		27.9		38.0		24.4
765L _ 15	15		11.9		15/16	23.8		27.9		38.0		24.4
765L _ 16	16		12.7		15/16	23.8		27.9		38.0		24.4
765L _ 18	18		15.1		1 1/16	27.0		29.7		39.8		24.4
765L _ 20	20		15.9		1 3/8	34.9		34.5		44.6		26.0
765L _ 22	22		18.3		1 3/8	34.9		34.5		44.6		26.0
765L _ 25	25		21.8		1 3/8	34.9		36.8		49.1		31.3
765L _ 38	*38		33.7		-	55.0		56.4		84.0		49.4
765L _ 50	*50		45.2		2 3/4	69.9		68.9		106.0		65.0

TUBE (INCH) TO TUBE (INCH)

Ordering Information	A Tube O.D.		D		W Wrench Flat		N		E		I	
	inch	mm	inch	mm	inch	mm	inch	mm	inch	mm	inch	mm
765L _ 1/16	1/16	1.58	.05	1.27	3/8	9.5	.55	14.00	.70	17.80	.34	.86
765L _ 1/8	1/8	3.17	.09	2.28	3/8	9.5	.62	15.74	.88	22.35	.50	12.7
765L _ 3/16	3/16	4.76	.12	3.04	1/2	12.7	.74	18.80	1.00	25.40	.54	13.7
765L _ 1/4	1/4	6.35	.19	4.82	1/2	12.7	.77	19.55	1.06	26.92	.60	15.2
765L _ 5/16	5/16	7.93	.25	6.35	9/16	14.3	.84	21.33	1.13	28.70	.64	16.2
765L _ 3/8	3/8	9.52	.28	7.11	5/8	15.9	.91	23.11	1.20	30.48	.66	16.8
765L _ 1/2	1/2	12.70	.41	10.41	13/16	20.6	1.02	25.90	1.42	36.06	.90	22.9
765L _ 5/8	5/8	15.87	.50	12.70	15/16	23.8	1.10	27.94	1.50	38.10	.96	24.4
765L _ 3/4	3/4	19.05	.62	15.74	1 1/16	27.0	1.17	29.70	1.57	39.90	.96	24.4
765L _ 7/8	7/8	22.22	.72	18.29	1 3/8	34.9	1.36	34.54	1.76	44.70	1.02	25.9
765L _ 1	1	25.40	.88	22.35	1 3/8	34.9	1.45	36.83	1.93	49.00	1.23	31.2
765L _ 1 1/4	*1 1/4	31.75	1.09	27.70	1 11/16	42.9	1.75	44.50	2.62	66.55	1.62	41.2
765L _ 1 1/2	*1 1/2	38.10	1.34	34.00	2	50.8	2.00	50.80	3.07	77.98	1.97	50.0
765L _ 2	*2	50.80	1.81	45.97	2 3/4	69.9	2.75	69.85	4.22	107.19	2.66	67.6

* Including low friction paste, See page 89

"D" - Dimension is minimum opening. Dimensions are for reference only, and are subject to change without notice.

**765 LR
REDUCING UNION ELBOW**

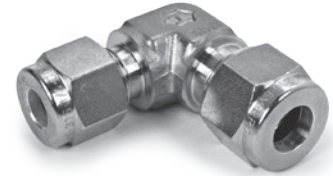
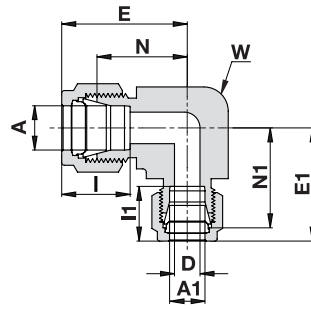

TUBE (METRIC) TO TUBE (INCH)

Ordering Information	A		A1		E		E1		I		I1		D	W Wrench Flat		N		N1	
	Tube O.D.		Tube O.D.		mm		mm		mm		mm			in	mm	mm		mm	
	mm	inch	mm	inch	mm	mm	mm	mm	mm	mm	mm	mm		mm	in	mm	mm	mm	mm
765LR _ 6 X 1/4	6	1/4	27.0	26.9	15.3	15.2	4.8	1/2	12.7	19.6	19.6								
765LR _ 8 X 1/4	8	1/4	28.8	28.7	16.2	15.2	4.8	9/16	14.3	21.3	21.3								

TUBE (INCH) TO TUBE (INCH)

Ordering Information	A		A1		E		E1		I		I1		D	W Wrench Flat		N		N1		
	Tube O.D.		Tube O.D.		in		mm		in		mm			in	mm	in	mm	in	mm	
	in	mm	in	mm	in	mm	in	mm	in	mm	in	mm		in	mm	in	mm	in	mm	
765LR _ 3/8 X 1/4	3/8	9.52	1/4	6.35	1.20	30.48	1.20	30.48	.66	16.8	.60	15.2	.19	4.82	5/8	15.9	.91	23.11	.91	23.11
765LR _ 5/8 X 3/8	5/8	15.87	3/8	9.52	1.50	38.10	1.39	35.31	.96	24.4	.66	16.8	.28	7.11	15/16	23.8	1.10	27.94	1.10	27.94

"D" - Dimension is minimum opening. Dimensions are for reference only, and are subject to change without notice.

**766 L
FEMALE CONNECTOR**

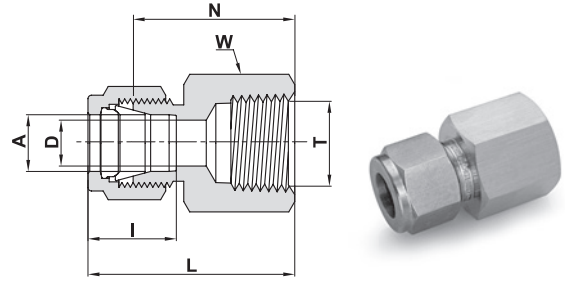

TUBE (METRIC) TO FEMALE NPT THREAD

Ordering Information	A	T	D	W	N	L	I
	Tube O.D. mm	(NPT) inch	mm	Hex. Flat mm	mm	mm	mm
766L_3 X 1/8	3	1/8	2.4	14	22.1	28.7	12.9
766L_3 X 1/4	3	1/4	2.4	19	26.9	33.5	12.9
766L_4 X 1/8	4	1/8	2.4	14	23.1	29.7	13.7
766L_6 X 1/8	6	1/8	4.8	14	23.9	31.3	15.3
766L_6 X 1/4	6	1/4	4.8	19	28.4	35.8	15.3
766L_6 X 3/8	6	3/8	4.8	22	30.2	37.6	15.3
766L_6 X 1/2	6	1/2	4.8	27	35.1	42.5	15.3
766L_8 X 1/8	8	1/8	6.4	15	24.6	32.1	16.2
766L_8 X 1/4	8	1/4	6.4	19	29.5	37.0	16.2
766L_8 X 3/8	8	3/8	6.4	22	31.0	38.5	16.2
766L_8 X 1/2	8	1/2	6.4	27	35.8	43.3	16.2
766L_10 X 1/4	10	1/4	7.9	19	30.2	37.8	17.2
766L_10 X 3/8	10	3/8	7.9	22	31.8	39.4	17.2
766L_10 X 1/2	10	1/2	7.9	27	36.6	44.2	17.2
766L_12 X 1/4	12	1/4	9.5	22	30.2	40.3	22.8
766L_12 X 3/8	12	3/8	9.5	22	31.8	41.9	22.8
766L_12 X 1/2	12	1/2	9.5	27	36.6	46.7	22.8
766L_15 X 1/2	15	1/2	11.9	27	36.6	46.7	24.4
766L_16 X 1/2	16	1/2	12.7	27	36.8	46.9	24.4
766L_20 X 1/2	20	1/2	15.9	30	37.8	47.9	26.0
766L_20 X 3/4	20	3/4	15.9	35	39.6	49.7	26.0
766L_22 X 3/4	22	3/4	18.3	35	39.6	49.7	26.0
766L_22 X 1	22	1	18.3	41	47.8	57.9	26.0
766L_25 X 3/4	25	3/4	21.8	35	41.1	53.4	31.3
766L_25 X 1	25	1	21.8	41	50.0	62.3	31.3

"D" - Dimension is minimum opening. Dimensions are for reference only, and are subject to change without notice.

Cont'd next page

766 L FEMALE CONNECTOR

(Cont'd)

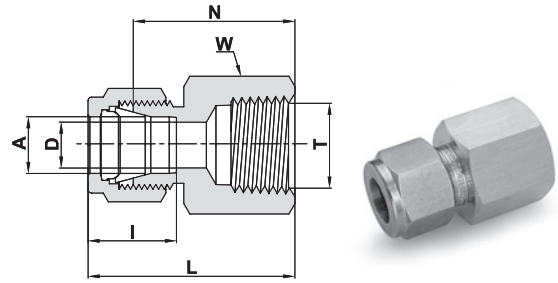

TUBE (INCH) TO FEMALE NPT THREAD

Ordering Information	A Tube O.D.		T (NPT)	D		W Hex Flat	N		L		I	
	inch	mm	inch	inch	mm	inch	inch	mm	inch	mm	inch	mm
766L_ 1/16 X 1/16	1/16	1.58	1/16	.05	1.27	7/16	.78	19.81	.93	23.62	.34	8.6
766L_ 1/16 X 1/8	1/16	1.58	1/8	.05	1.27	9/16	.81	20.57	.96	24.38	.34	8.6
766L_ 1/8 X 1/8	1/8	3.17	1/8	.09	2.28	9/16	.87	22.10	1.13	28.70	.50	12.7
766L_ 1/8 X 1/4	1/8	3.17	1/4	.09	2.28	3/4	1.06	26.92	1.32	33.52	.50	12.7
766L_ 3/16 X 1/8	3/16	4.76	1/8	.12	3.04	9/16	.91	23.11	1.17	29.71	.54	13.7
766L_ 1/4 X 1/8	1/4	6.35	1/8	.19	4.82	9/16	.94	23.87	1.23	31.24	.60	15.2
766L_ 1/4 X 1/4	1/4	6.35	1/4	.19	4.82	3/4	1.12	28.44	1.41	35.81	.60	15.2
766L_ 1/4 X 3/8	1/4	6.35	3/8	.19	4.82	7/8	1.19	30.22	1.48	37.59	.60	15.2
766L_ 1/4 X 1/2	1/4	6.35	1/2	.19	4.82	1 1/16	1.38	35.00	1.67	42.42	.60	15.2
766L_ 5/16 X 1/8	5/16	7.93	1/8	.25	6.35	9/16	.97	24.63	1.26	32.00	.64	16.2
766L_ 5/16 X 1/4	5/16	7.93	1/4	.25	6.35	3/4	1.16	29.46	1.45	36.83	.64	16.2
766L_ 3/8 X 1/8	3/8	9.52	1/8	.28	7.11	5/8	1.00	25.40	1.29	32.76	.66	16.8
766L_ 3/8 X 1/4	3/8	9.52	1/4	.28	7.11	3/4	1.19	30.22	1.48	37.59	.66	16.8
766L_ 3/8 X 3/8	3/8	9.52	3/8	.28	7.11	7/8	1.25	31.75	1.54	39.11	.66	16.8
766L_ 3/8 X 1/2	3/8	9.52	1/2	.28	7.11	1 1/16	1.44	36.57	1.73	43.94	.66	16.8
766L_ 3/8 X 3/4	3/8	9.52	3/4	.28	7.11	1 5/16	1.59	40.40	1.88	47.75	.66	16.8
766L_ 1/2 X 1/4	1/2	12.70	1/4	.41	10.41	13/16	1.19	30.22	1.59	40.38	.90	22.9
766L_ 1/2 X 3/8	1/2	12.70	3/8	.41	10.41	7/8	1.25	31.75	1.65	41.91	.90	22.9
766L_ 1/2 X 1/2	1/2	12.70	1/2	.41	10.41	1 1/16	1.44	36.57	1.84	46.73	.90	22.9
766L_ 1/2 X 3/4	1/2	12.70	3/4	.41	10.41	1 5/16	1.50	38.10	1.90	48.26	.90	22.9
766L_ 5/8 X 3/8	5/8	15.87	3/8	.50	12.70	15/16	1.25	31.75	1.65	41.91	.96	24.4
766L_ 5/8 X 1/2	5/8	15.87	1/2	.50	12.70	1 1/16	1.44	36.57	1.84	46.73	.96	24.4
766L_ 5/8 X 3/4	5/8	15.87	3/4	.50	12.70	1 5/16	1.50	38.10	1.90	48.26	.96	24.4
766L_ 3/4 X 1/2	3/4	19.05	1/2	.62	15.75	1 1/16	1.44	36.57	1.84	46.73	.96	24.4
766L_ 3/4 X 3/4	3/4	19.05	3/4	.62	15.75	1 5/16	1.50	38.10	1.90	48.26	.96	24.4
766L_ 7/8 X 3/4	7/8	22.22	3/4	.72	18.28	1 5/16	1.56	39.62	1.96	49.78	1.02	25.9
766L_ 1 X 3/4	1	25.40	3/4	.88	22.35	1 3/8	1.62	41.14	2.10	53.34	1.23	31.2
766L_ 1 X 1	1	25.40	1	.88	22.35	1 5/8	1.97	50.03	2.45	62.23	1.23	31.2
766L_ 1 1/4 X 1 1/4	*1 1/4	31.75	1 1/4	1.09	27.70	2 1/4	2.07	52.59	2.94	74.68	1.62	41.2
766L_ 1 1/2 X 1 1/2	*1 1/2	38.10	1 1/2	1.34	34.00	2 3/8	2.21	56.13	3.28	83.31	1.97	50.0
766L_ 2 X 2	*2	50.80	2	1.81	45.97	2 7/8	2.53	64.26	4.00	101.60	2.66	67.6

* Including low friction paste, See page 89

"D" - Dimension is minimum opening. Dimensions are for reference only, and are subject to change without notice.

766 LR FEMALE CONNECTOR

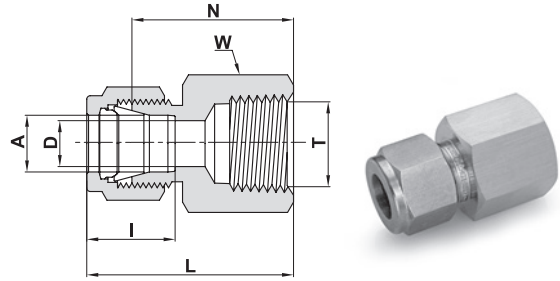

TUBE (METRIC) TO FEMALE ISO TAPERED THREAD

Ordering Information	A	T	D	W	N	L	I
	Tube O.D.	(ISO)	mm	Hex. Flat	mm	mm	mm
	mm	inch	mm	mm	mm	mm	mm
766LR_3 X 1/8	3	R-1/8	2.4	14	22.1	28.7	12.9
766LR_6 X 1/8	6	R-1/8	4.8	14	23.9	31.3	15.3
766LR_6 X 1/4	6	R-1/4	4.8	19	28.4	35.8	15.3
766LR_6 X 3/8	6	R-3/8	4.8	22	30.2	37.6	15.3
766LR_6 X 1/2	6	R-1/2	4.8	27	35.1	42.5	15.3
766LR_8 X 1/8	8	R-1/8	6.4	15	24.6	32.1	16.2
766LR_8 X 1/4	8	R-1/4	6.4	19	29.5	37.0	16.2
766LR_8 X 3/8	8	R-3/8	6.4	22	31.0	38.5	16.2
766LR_8 X 1/2	8	R-1/2	6.4	27	35.8	43.3	16.2
766LR_10 X 1/8	10	R-1/8	7.9	18	25.4	33.0	17.2
766LR_10 X 1/4	10	R-1/4	7.9	19	30.2	37.8	17.2
766LR_10 X 3/8	10	R-3/8	7.9	22	31.8	39.4	17.2
766LR_10 X 1/2	10	R-1/2	7.9	27	36.6	44.2	17.2
766LR_12 X 1/8	12	R-1/8	8.3	22	25.4	35.5	22.8
766LR_12 X 1/4	12	R-1/4	9.5	22	30.2	40.3	22.8
766LR_12 X 3/8	12	R-3/8	9.5	22	31.8	41.9	22.8
766LR_12 X 1/2	12	R-1/2	9.5	27	36.6	46.7	22.8
766LR_12 X 3/4	12	R-3/4	9.5	35	38.9	49.0	22.8
766LR_15 X 3/8	15	R-3/8	11.9	24	31.8	41.9	24.4
766LR_15 X 1/2	15	R-1/2	11.9	27	36.6	46.7	24.4
766LR_20 X 1/2	20	R-1/2	15.9	30	37.8	47.9	26.0
766LR_20 X 3/4	20	R-3/4	15.9	35	39.6	49.7	26.0
766LR_22 X 3/4	22	R-3/4	18.3	35	39.6	49.7	26.0
766LR_22 X 1	22	R-1	18.3	41	47.8	57.9	26.0
766LR_25 X 3/4	25	R-3/4	21.8	35	41.1	53.4	31.3
766LR_25 X 1	25	R-1	21.8	41	50.0	62.3	31.3

Reference Specifications:

DIN -2999
BS -21
JIS -B0203
ISO -7/1-BSP-T

Designation:

Marking LR on Hex.

"D" - Dimension is minimum opening. Dimensions are for reference only, and are subject to change without notice.

Cont'd next page

766 LR FEMALE CONNECTOR

(Cont'd)

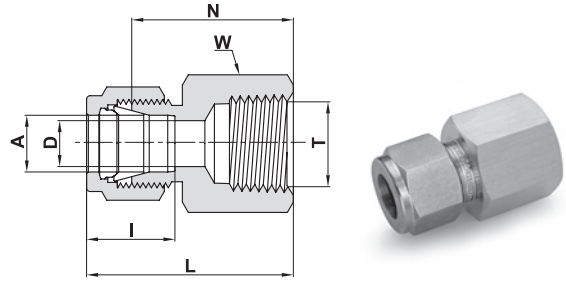

TUBE (INCH) TO FEMALE NPT THREAD

Ordering Information	A Tube O.D.		T (ISO)	D		W Hex Flat	N		L		I	
	inch	mm	inch	inch	mm	inch	inch	mm	inch	mm	inch	mm
766LR _ 1/16 X 1/16	1/16	1.58	1/16	.05	1.27	7/16	.78	19.81	.93	23.62	.34	8.6
766LR _ 1/16 X 1/8	1/16	1.58	1/8	.05	1.27	9/16	.81	20.57	.96	24.38	.34	8.6
766LR _ 1/8 X 1/8	1/8	3.17	1/8	.09	2.28	9/16	.87	22.10	1.13	28.70	.50	12.7
766LR _ 1/8 X 1/4	1/8	3.17	1/4	.09	2.28	3/4	1.06	26.92	1.32	33.52	.50	12.7
766LR _ 3/16 X 1/8	3/16	4.76	1/8	.12	3.04	9/16	.91	23.11	1.17	29.71	.54	13.7
766LR _ 1/4 X 1/8	1/4	6.35	1/8	.19	4.82	9/16	.94	23.87	1.23	31.24	.60	15.2
766LR _ 1/4 X 1/4	1/4	6.35	1/4	.19	4.82	3/4	1.12	28.44	1.41	35.81	.60	15.2
766LR _ 1/4 X 3/8	1/4	6.35	3/8	.19	4.82	7/8	1.19	30.22	1.48	37.59	.60	15.2
766LR _ 1/4 X 1/2	1/4	6.35	1/2	.19	4.82	1 1/16	1.38	35.00	1.67	42.42	.60	15.2
766LR _ 5/16 X 1/4	5/16	7.93	1/4	.25	6.35	3/4	1.16	29.46	1.45	36.83	.64	16.2
766LR _ 3/8 X 1/8	3/8	9.52	1/8	.28	7.11	5/8	1.00	25.40	1.29	32.76	.66	16.8
766LR _ 3/8 X 1/4	3/8	9.52	1/4	.28	7.11	3/4	1.19	30.22	1.48	37.59	.66	16.8
766LR _ 3/8 X 3/8	3/8	9.52	3/8	.28	7.11	7/8	1.25	31.75	1.54	39.11	.66	16.8
766LR _ 3/8 X 1/2	3/8	9.52	1/2	.28	7.11	1 1/16	1.44	36.57	1.73	43.94	.66	16.8
766LR _ 1/2 X 1/4	1/2	12.70	1/4	.41	10.41	13/16	1.19	30.20	1.59	40.38	.90	22.9
766LR _ 1/2 X 3/8	1/2	12.70	3/8	.41	10.41	7/8	1.25	31.75	1.65	41.91	.90	22.9
766LR _ 1/2 X 1/2	1/2	12.70	1/2	.41	10.41	1 1/16	1.44	36.57	1.84	46.73	.90	22.9
766LR _ 5/8 X 1/2	5/8	15.87	1/2	.50	12.70	1 1/16	1.44	36.57	1.84	46.73	.96	24.4
766LR _ 3/4 X 1/2	3/4	19.05	1/2	.62	15.75	1 1/16	1.44	36.57	1.84	46.73	.96	24.4
766LR _ 3/4 X 3/4	3/4	19.05	3/4	.62	15.75	1 5/16	1.50	38.10	1.90	48.26	.96	24.4
766LR _ 1 X 3/4	1	25.40	3/4	.88	22.35	1 3/8	1.62	41.14	2.10	53.34	1.23	31.2
766LR _ 1 X 1	1	25.40	1	.88	22.35	1 5/8	1.97	50.03	2.45	62.23	1.23	31.2

Reference Specifications:

DIN -2999
BS -21
JIS -B0203
ISO -7/1-BSP-T

Designation:

Marking LR on Hex.

"D" - Dimension is minimum opening. Dimensions are for reference only, and are subject to change without notice.

766 LG FEMALE CONNECTOR

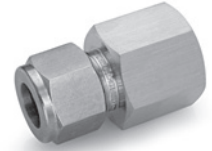
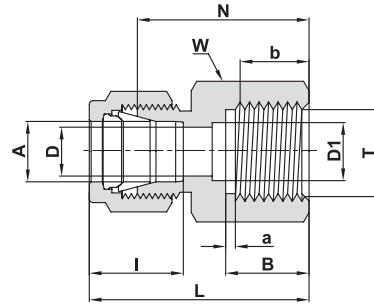

TUBE (METRIC) TO FEMALE ISO PARALLEL THREAD

Ordering Information	A Tube O.D.		T (ISO)	D	D1	W Hex. Flat	B	b Min	a Min	N	L	I
	mm	inch	inch	mm	mm	mm	mm	mm	mm	mm	mm	mm
766LG _ 3 X 1/4	3		G-1/4	2.4	5.5	19	13.0	9.5	1.6	28.7	35.3	12.9
766LG _ 6 X 1/8	6		G-1/8	4.0	4.0	14	10.0	7.0	1.6	25.0	32.4	15.3
766LG _ 6 X 1/4	6		G-1/4	4.8	5.5	19	13.0	9.5	1.6	30.2	37.6	15.3
766LG _ 6 X 3/8	6		G-3/8	4.8	6.5	24	14.1	10.0	1.6	30.2	37.6	15.3
766LG _ 6 X 1/2	6		G-1/2	4.8	7.0	27	19.0	15.0	1.6	36.1	43.5	15.3
766LG _ 8 X 1/4	8		G-1/4	5.5	5.5	19	13.0	9.5	1.6	31.0	38.5	16.2
766LG _ 8 X 3/8	8		G-3/8	6.4	6.4	24	14.1	10.0	1.6	28.7	36.2	16.2
766LG _ 8 X 1/2	8		G-1/2	7.0	7.0	27	19.0	15.0	1.6	33.5	41.0	16.2
766LG _ 10 X 1/4	10		G-1/4	5.5	5.5	19	13.0	9.5	1.6	31.8	39.4	17.2
766LG _ 10 X 3/8	10		G-3/8	6.5	6.5	24	14.1	10.0	1.6	31.2	38.8	17.2
766LG _ 10 X 1/2	10		G-1/2	7.0	7.0	27	19.0	15.0	1.6	34.5	42.1	17.2
766LG _ 12 X 1/4	12		G-1/4	5.5	5.5	22	13.0	9.5	1.6	31.8	41.9	22.8
766LG _ 12 X 3/8	12		G-3/8	6.5	6.5	24	14.1	10.0	1.6	34.3	44.4	22.8
766LG _ 12 X 1/2	12		G-1/2	7.0	7.0	27	19.0	15.0	1.6	38.1	48.2	22.8
766LG _ 20 X 1/2	20		G-1/2	7.0	7.0	30	19.0	15.0	1.6	44.2	54.3	26.0
766LG _ 22 X 1/2	22		G-1/2	7.0	7.0	30	19.0	15.0	1.6	44.2	54.3	26.0

TUBE (INCH) TO FEMALE ISO PARALLEL THREAD

Ordering Information	A Tube O.D.		T (ISO)	D		D1		W Hex. Flat	B		b Min		a Min		N		L		I	
	inch	mm	inch	inch	mm	inch	mm	inch	inch	mm	inch	mm	inch	mm	inch	mm	inch	mm	inch	mm
766LG _ 1/8 X 1/4	1/8	3.17	G-1/4	.09	2.3	.22	5.5	3/4	.51	13.0	.37	9.5	.06	1.6	1.13	28.7	1.39	35.3	.50	12.7
766LG _ 1/4 X 1/8	1/4	6.35	G-1/8	.16	4.0	.16	4.0	9/16	.40	10.0	.28	7.0	.06	1.6	.98	25.0	1.27	32.4	.60	15.2
766LG _ 1/4 X 1/4	1/4	6.35	G-1/4	.19	4.8	.22	5.5	3/4	.51	13.0	.37	9.5	.06	1.6	1.19	30.2	1.48	37.6	.60	15.2
766LG _ 1/4 X 3/8	1/4	6.35	G-3/8	.19	4.8	.26	6.5	15/16	.56	14.1	.39	10.0	.06	1.6	1.19	30.2	1.48	37.6	.60	15.2
766LG _ 1/4 X 1/2	1/4	6.35	G-1/2	.19	4.8	.28	7.0	1 1/16	.74	19.0	.59	15.0	.06	1.6	1.42	36.1	1.71	43.4	.60	15.2
766LG _ 5/16 X 1/4	5/16	7.93	G-1/4	.22	5.5	.22	5.5	3/4	.51	13.0	.37	9.5	.06	1.6	1.22	31.0	1.51	38.4	.64	16.2
766LG _ 5/16 X 1/2	5/16	7.93	G-1/2	.28	7.0	.28	7.0	1 1/16	.74	19.0	.59	15.0	.06	1.6	1.32	33.5	1.61	40.9	.64	16.2
766LG _ 3/8 X 1/4	3/8	9.52	G-1/4	.22	5.5	.22	5.5	3/4	.51	13.0	.37	9.5	.06	1.6	1.25	31.8	1.54	39.1	.66	16.8
766LG _ 3/8 X 3/8	3/8	9.52	G-3/8	.26	6.6	.26	6.6	15/16	.56	14.1	.39	10.0	.06	1.6	1.23	31.2	1.52	38.6	.66	16.8
766LG _ 3/8 X 1/2	3/8	9.52	G-1/2	.28	7.0	.28	7.0	1 1/16	.74	19.0	.59	15.0	.06	1.6	1.36	34.5	1.65	41.9	.66	16.8
766LG _ 1/2 X 3/8	1/2	12.7	G-3/8	.26	6.5	.26	6.5	15/16	.56	14.1	.39	10.0	.06	1.6	1.35	34.3	1.75	44.5	.90	22.9
766LG _ 1/2 X 1/2	1/2	12.7	G-1/2	.28	7.0	.28	7.0	1 1/16	.74	19.0	.59	15.0	.06	1.6	1.50	38.1	1.90	48.2	.90	22.9

Reference Specifications:

DIN -ISO 228/1
BS -2779
JIS -B0202
ISO -228/1-BSP-P

Designation:

Marking LG on Hex.

"D" - Dimension is minimum opening. Dimensions are for reference only, and are subject to change without notice.

767 LT REDUCER

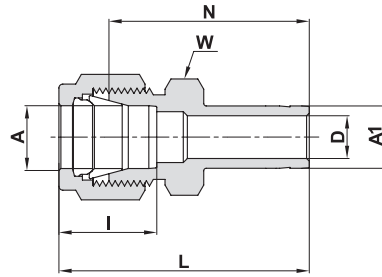

TUBE (METRIC) TO STUB (METRIC)

Ordering Information	A	A1	D	W	N	L	I
	Tube O.D.	Tube O.D.		Hex. Flat			
	mm	mm	mm	mm	mm	mm	mm
767LT_2 X 3	2	3	1.7	12	26.9	33.5	12.9
767LT_3 X 4	3	4	2.4	12	28.4	35.0	12.9
767LT_3 X 6	3	6	2.4	12	29.5	36.1	12.9
767LT_3 X 10	3	10	2.4	14	31.8	38.4	12.9
767LT_4 X 6	4	6	2.4	12	30.5	37.1	13.7
767LT_6 X 3	6	3	2.1	14	29.5	36.9	15.3
767LT_6 X 8	6	8	4.8	14	32.5	39.9	15.3
767LT_6 X 10	6	10	4.8	14	33.3	40.7	15.3
767LT_6 X 12	6	12	4.8	14	38.9	46.3	15.3
767LT_6 X 18	6	18	4.8	22	42.2	49.6	15.3
767LT_8 X 6	8	6	4.0	15	32.8	40.3	16.2
767LT_8 X 10	8	10	6.4	15	34.5	42.0	16.2
767LT_8 X 12	8	12	6.4	15	40.1	47.6	16.2
767LT_10 X 6	10	6	4.0	18	34.8	42.4	17.2
767LT_10 X 8	10	8	5.6	18	35.8	43.4	17.2
767LT_10 X 12	10	12	7.9	18	42.2	49.8	17.2
767LT_10 X 15	10	15	7.9	18	43.7	51.3	17.2
767LT_10 X 18	10	18	7.9	22	43.7	51.3	17.2
767LT_12 X 6	12	6	4.0	22	34.8	44.9	22.8
767LT_12 X 8	12	8	5.6	22	35.8	45.9	22.8
767LT_12 X 10	12	10	7.1	22	36.6	46.7	22.8
767LT_12 X 16	12	16	9.5	22	43.7	53.8	22.8
767LT_12 X 18	12	18	9.5	22	43.7	53.8	22.8
767LT_12 X 20	12	20	9.5	22	46.0	56.1	22.8
767LT_12 X 22	12	22	9.5	24	46.0	56.1	22.8
767LT_12 X 25	12	25	9.5	27	52.3	62.4	22.8
767LT_16 X 12	16	12	8.8	24	42.9	53.0	24.4
767LT_18 X 12	18	12	8.8	27	44.5	54.6	24.4
767LT_18 X 16	18	16	12.7	27	46.0	56.1	24.4
767LT_18 X 20	18	20	15.1	27	47.5	57.6	24.4
767LT_18 X 22	18	22	15.1	27	47.5	57.6	24.4
767LT_18 X 25	18	25	15.1	27	52.3	62.4	24.4
767LT_20 X 16	20	16	12.7	30	47.8	57.9	26.0
767LT_20 X 18	20	18	13.9	30	47.8	57.9	26.0
767LT_20 X 22	20	22	15.9	30	49.3	59.4	26.0
767LT_20 X 25	20	25	15.9	30	54.1	64.2	26.0
767LT_22 X 18	22	18	13.9	30	47.8	57.9	26.0
767LT_22 X 20	22	20	15.1	30	49.3	59.4	26.0
767LT_22 X 25	22	25	18.3	30	54.1	64.2	26.0
767LT_25 X 18	25	18	13.9	35	50.8	63.1	31.3
767LT_25 X 20	25	20	15.1	35	52.3	64.6	31.3

"D" - Dimension is minimum opening. Dimensions are for reference only, and are subject to change without notice.

Cont'd next page

**767 LT
REDUCER** (cont'd)

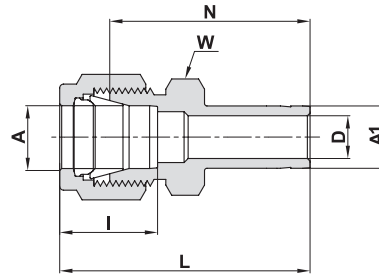

TUBE (METRIC) TO STUB (INCH)

Ordering Information	A	A1	D	W	N	L	I
	Tube O.D.	Tube O.D.	mm	Hex. Flat	mm	mm	mm
	mm	inch	mm	mm	mm	mm	mm
767LT _2 X 1/8	2	1/8	1.7	12	26.9	33.5	12.9
767LT _3 X 1/8	3	1/8	2.2	12	26.9	33.5	12.9
767LT _3 X 1/4	3	1/4	2.4	12	29.5	36.1	12.9
767LT _4 X 1/4	4	1/4	2.4	12	30.5	37.1	13.7
767LT _6 X 1/8	6	1/8	2.2	14	29.5	36.9	15.3
767LT _6 X 5/16	6	5/16	4.8	14	32.5	39.9	15.3
767LT _6 X 3/8	6	3/8	4.8	14	33.3	40.7	15.3
767LT _6 X 1/2	6	1/2	4.8	14	38.9	46.3	15.3
767LT _8 X 3/8	8	3/8	6.4	15	34.5	42.0	16.2
767LT _8 X 1/2	8	1/2	6.4	15	40.1	47.6	16.2
767LT _10 X 3/8	10	3/8	6.8	18	36.6	44.2	17.2
767LT _10 X 1/2	10	1/2	7.9	18	42.2	49.8	17.2
767LT _12 X 1/2	12	1/2	9.4	22	42.2	52.3	22.8
767LT _12 X 3/4	12	3/4	9.4	22	43.7	53.8	22.8
767LT _18 X 3/4	18	3/4	15.0	27	46.0	56.1	24.4
767LT _18 X 1	18	1	15.1	27	52.3	62.4	24.4
767LT _25 X 1	25	1	20.3	35	57.2	69.5	31.3

HEAT EXCHANGER TEE; INFORMATION

UNION TEE - 764 L

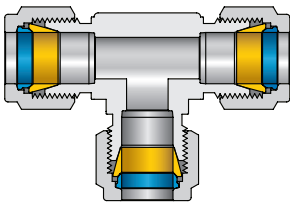

REDUCER - 767 LT

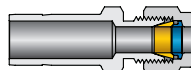

Heat exchanger tee made with Let-Lok tube fittings:

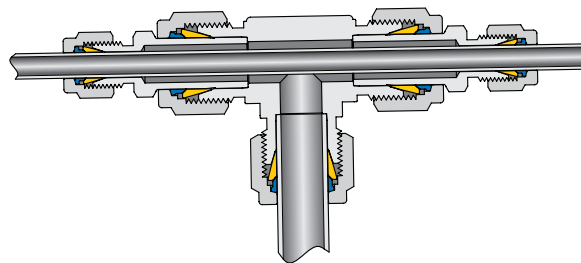

"D" - Dimension is minimum opening. Dimensions are for reference only, and are subject to change without notice.

Cont'd next page

767 LT
REDUCER (Cont'd)

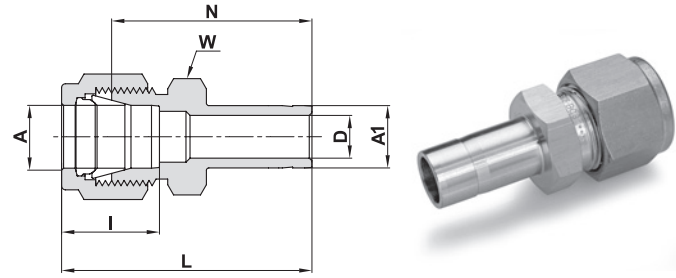

TUBE (INCH) TO STUB (INCH)

Ordering Information	A Tube O.D.		A1 Tube O.D.		D		W Hex Flat	N		L		I	
	inch	mm	inch	mm	inch	mm	inch	inch	mm	inch	mm	inch	mm
767LT _ 1/16 X 1/8	1/16	1.58	1/8	3.17	.05	1.27	5/16	1.00	25.40	1.15	29.21	.34	8.6
767LT _ 1/16 X 1/4	1/16	1.58	1/4	6.35	.05	1.27	5/16	1.09	27.68	1.24	31.50	.34	8.6
767LT _ 1/8 X 1/16	1/8	3.17	1/16	1.58	.03	.76	7/16	.88	22.35	1.14	28.96	.50	12.7
767LT _ 1/8 X 1/8	1/8	3.17	1/8	3.17	.08	2.03	7/16	1.06	26.92	1.32	33.52	.50	12.7
767LT _ 1/8 X 3/16	1/8	3.17	3/16	4.76	.09	2.28	7/16	1.09	27.68	1.35	34.29	.50	12.7
767LT _ 1/8 X 1/4	1/8	3.17	1/4	6.35	.09	2.28	7/16	1.16	29.46	1.42	36.06	.50	12.7
767LT _ 1/8 X 3/8	1/8	3.17	3/8	9.52	.09	2.28	7/16	1.22	30.98	1.48	37.59	.50	12.7
767LT _ 1/8 X 1/2	1/8	3.17	1/2	12.70	.09	2.28	9/16	1.48	37.59	1.74	44.20	.50	12.7
767LT _ 3/16 X 1/8	3/16	4.76	1/8	3.17	.08	2.03	7/16	1.11	28.19	1.37	34.80	.54	13.7
767LT _ 3/16 X 1/4	3/16	4.76	1/4	6.35	.12	3.04	7/16	1.20	30.48	1.46	37.08	.54	13.7
767LT _ 1/4 X 1/8	1/4	6.35	1/8	3.17	.08	2.03	1/2	1.16	29.46	1.45	36.83	.60	15.2
767LT _ 1/4 X 3/16	1/4	6.35	3/16	4.76	.12	3.04	1/2	1.19	30.22	1.48	37.59	.60	15.2
767LT _ 1/4 X 1/4	1/4	6.35	1/4	6.35	.17	4.20	1/2	1.25	31.75	1.54	39.11	.60	15.2
767LT _ 1/4 X 5/16	1/4	6.35	5/16	7.93	.19	4.82	1/2	1.28	32.51	1.57	39.87	.60	15.2
767LT _ 1/4 X 3/8	1/4	6.35	3/8	9.52	.19	4.82	1/2	1.31	33.27	1.60	40.64	.60	15.2
767LT _ 1/4 X 1/2	1/4	6.35	1/2	12.70	.19	4.82	9/16	1.53	38.86	1.82	46.22	.60	15.2
767LT _ 1/4 X 5/8	1/4	6.35	5/8	15.87	.19	4.82	11/16	1.60	40.64	1.89	48.00	.60	15.2
767LT _ 1/4 X 3/4	1/4	6.35	3/4	19.05	.19	4.82	13/16	1.59	40.39	1.88	47.75	.60	15.2
767LT _ 5/16 X 3/8	5/16	7.93	3/8	9.52	.25	6.35	9/16	1.36	34.54	1.65	41.91	.64	16.2
767LT _ 5/16 X 1/2	5/16	7.93	1/2	12.70	.25	6.35	9/16	1.58	40.13	1.87	47.49	.64	16.2
767LT _ 3/8 X 1/4	3/8	9.52	1/4	6.35	.17	4.20	5/8	1.34	34.03	1.63	41.40	.66	16.8
767LT _ 3/8 X 3/8	3/8	9.52	3/8	9.52	.27	6.85	5/8	1.41	35.81	1.70	43.18	.66	16.8
767LT _ 3/8 X 1/2	3/8	9.52	1/2	12.70	.28	7.11	5/8	1.62	41.14	1.91	48.51	.66	16.8
767LT _ 3/8 X 5/8	3/8	9.52	5/8	15.87	.28	7.11	11/16	1.69	42.92	1.98	50.29	.66	16.8
767LT _ 3/8 X 3/4	3/8	9.52	3/4	19.05	.28	7.11	13/16	1.69	42.92	1.98	50.29	.66	16.8
767LT _ 1/2 X 1/4	1/2	12.70	1/4	6.35	.17	4.20	13/16	1.37	34.80	1.77	44.96	.90	22.9
767LT _ 1/2 X 3/8	1/2	12.70	3/8	9.52	.27	6.85	13/16	1.44	36.58	1.84	46.74	.90	22.9
767LT _ 1/2 X 1/2	1/2	12.70	1/2	12.70	.37	9.40	13/16	1.66	42.16	2.06	52.32	.90	22.9
767LT _ 1/2 X 5/8	1/2	12.70	5/8	15.87	.41	10.41	13/16	1.72	43.68	2.12	53.84	.90	22.9
767LT _ 1/2 X 3/4	1/2	12.70	3/4	19.05	.41	10.41	13/16	1.72	43.68	2.12	53.84	.90	22.9
767LT _ 1/2 X 1	1/2	12.70	1	25.40	.41	10.41	1 1/16	1.97	50.03	2.37	60.19	.90	22.9
767LT _ 5/8 X 3/4	5/8	15.87	3/4	19.05	.50	12.70	15/16	1.75	44.45	2.15	54.61	.96	24.4
767LT _ 5/8 X 7/8	5/8	15.87	7/8	22.22	.50	12.70	15/16	1.81	45.97	2.21	56.13	.96	24.4
767LT _ 5/8 X 1	5/8	15.87	1	25.40	.50	12.70	1 1/16	2.00	50.80	2.40	60.96	.96	24.4
767LT _ 3/4 X 1/2	3/4	19.05	1/2	12.70	.37	9.40	1 1/16	1.75	44.45	2.15	54.61	.96	24.4
767LT _ 3/4 X 1	3/4	19.05	1	25.40	.62	15.75	1 1/16	2.06	52.32	2.46	62.48	.96	24.4
767LT _ 1 X 1 1/4	1	25.40	*1 1/4	31.75	.88	22.35	1 3/8	2.69	68.33	3.17	80.52	1.23	31.2
767LT _ 1 X 1 1/2	1	25.40	*1 1/2	38.10	.88	22.35	1 5/8	3.03	76.96	3.51	89.15	1.23	31.2
767LT _ 1 1/4 X 1 1/2	1 1/4	31.75	*1 1/2	38.10	1.09	27.7	1 3/4	3.23	82.00	4.10	104.1	1.62	41.2

ASSEMBLY INSTRUCTIONS: Reducer tube to stub 767 LT

*Supplied assembled on tube stub end (A1) nut+front & back ferrule. Tighten the nut on the body 1/2 a turn with a wrench. Low friction paste, See page 89.
"D" - Dimension is minimum opening. Dimensions are for reference only, and are subject to change without notice.

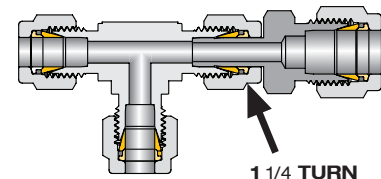

**767 LT
REDUCER** (Cont'd)

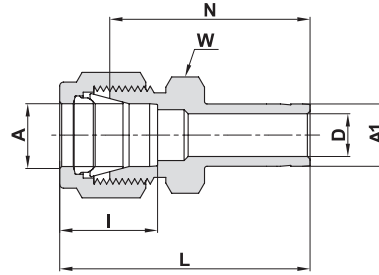

TUBE (INCH) TO STUB (METRIC)

Ordering Information	A Tube O.D.		A1 Tube O.D.	D		W Hex. Flat	N		L		I	
	inch	mm	mm	inch	mm	inch	inch	mm	inch	mm	inch	mm
	767LT _ 1/8 X 6	1/8	3.17	6	.09	2.30	7/16	1.16	29.46	1.42	36.06	.50
767LT _ 1/4 X 6	1/4	6.35	6	.16	4.00	1/2	1.25	31.75	1.54	39.11	.60	15.2
767LT _ 3/8 X 8	3/8	9.52	8	.22	5.60	5/8	1.42	36.06	1.71	43.43	.66	16.8
767LT _ 3/8 X 12	3/8	9.52	12	.28	7.11	5/8	1.62	41.15	1.91	48.51	.66	16.8

**767 LM
REDUCING PORT
CONNECTOR**

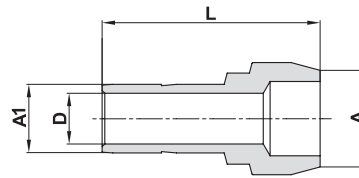

CONNECTS TWO LET-LOK® PORTS (METRIC)

Ordering Information	A Tube O.D.		A1 Tube O.D.	D	L
	mm	mm	mm	mm	mm
767LM _ 6 X 3	6	3	2.1	22.9	
767LM _ 8 X 6	8	6	4.0	24.7	
767LM _ 10 X 6	10	6	4.0	25.8	
767LM _ 10 X 8	10	8	5.6	26.1	
767LM _ 12 X 6	12	6	4.0	29.1	
767LM _ 12 X 8	12	8	5.6	29.8	
767LM _ 12 X 10	12	10	7.1	30.6	
767LM _ 16 X 12	16	12	8.8	37.5	
767LM _ 38 X 25	*38	25	19.8	65.8	

CONNECTS TWO LET-LOK® PORTS (INCH)

Ordering Information	A Tube O.D.		A1 Tube O.D.		D		L	
	inch	mm	inch	mm	inch	mm	inch	mm
767LM _ 1/8 X 1/16	1/8	3.17	1/16	1.58	.03	0.75	.68	17.3
767LM _ 1/4 X 1/16	1/4	6.35	1/16	1.58	.03	0.75	.71	18.0
767LM _ 1/4 X 1/8	1/4	6.35	1/8	3.17	.09	2.20	.89	22.6
767LM _ 3/8 X 1/8	3/8	9.52	1/8	3.17	.09	2.20	.91	23.2
767LM _ 3/8 X 1/4	3/8	9.52	1/4	6.35	.17	4.20	.98	24.9
767LM _ 1/2 X 1/4	1/2	12.70	1/4	6.35	.17	4.20	1.15	29.2
767LM _ 1/2 X 3/8	1/2	12.70	3/8	9.52	.28	7.10	1.20	30.5
767LM _ 3/4 X 1/2	3/4	19.05	1/2	12.70	.39	9.90	1.49	37.9

ASSEMBLY INSTRUCTIONS
Reducer Port Connector 767 LM

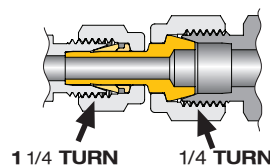

* Supplied assembled with Nut. Low friction paste, See page 89
"D" - Dimension is minimum opening. Dimensions are for reference only, and are subject to change without notice.

767 LP PORT CONNECTOR

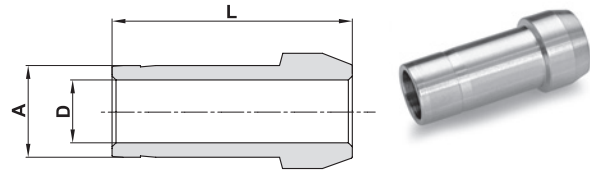

CONNECTS TWO LET-LOK® PORTS (METRIC)

Ordering Information	A Tube O.D.		D		L	
	inch	mm	inch	mm	inch	mm
767LP_3		3		2.1		22.2
767LP_6		6		4.0		25.0
767LP_8		8		5.6		25.9
767LP_10		10		7.1		27.1
767LP_12		12		8.8		36.2
767LP_16		16		12.7		37.4
767LP_18		18		13.9		37.4
767LP_38		*38		31.6		81.9
767LP_50		*50		42.8		114.0

CONNECTS TWO LET-LOK® PORTS (INCH)

Ordering Information	A Tube O.D.		D		L	
	inch	mm	inch	mm	inch	mm
767LP_1/16	1/16	1.58	.03	0.75	.54	13.7
767LP_1/8	1/8	3.17	.09	2.20	.88	22.4
767LP_1/4	1/4	6.35	.17	4.20	.98	24.9
767LP_5/16	5/16	7.93	.24	6.00	1.02	25.9
767LP_3/8	3/8	9.52	.27	6.85	1.03	26.2
767LP_1/2	1/2	12.70	.37	9.40	1.41	35.8
767LP_3/4	3/4	19.05	.59	15.00	1.47	37.3
767LP_1	1	25.40	.80	20.30	1.90	48.1
767LP_1 1/4	*1 1/4	31.75	1.02	26.00	2.72	69.1
767LP_1 1/2	*1 1/2	38.10	1.25	31.60	3.31	84.1
767LP_2	*2	50.80	1.72	43.67	4.56	115.8

Port Connector 767LP

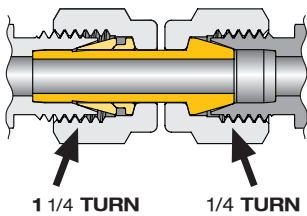

* Supplied assembled with Nuts and Ferrules. Low friction paste, See page 89
 D - Dimension is minimum opening. Dimensions are for reference only, and are subject to change without notice.

768 L MALE CONNECTOR

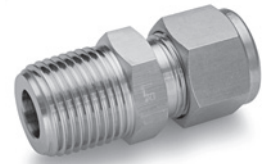
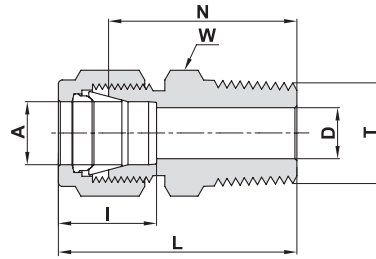

TUBE (METRIC) MALE NPT THREAD

Ordering Information	A	T	D	W	N	L	I
	Tube O.D.	(NPT)		Hex. Flat			
	mm	inch	mm	mm	mm	mm	mm
768L _ 2 X 1/8	2	1/8	1.7	12	23.9	30.5	12.9
768L _ 3 X 1/8	3	1/8	2.4	12	23.9	30.5	12.9
768L _ 3 X 1/4	3	1/4	2.4	14	29.0	35.6	12.9
768L _ 4 X 1/8	4	1/8	2.4	12	24.6	31.2	13.7
768L _ 4 X 1/4	4	1/4	2.4	14	29.7	36.3	13.7
768L _ 6 X 1/8	6	1/8	4.8	14	25.4	32.8	15.3
768L _ 6 X 1/4	6	1/4	4.8	14	30.5	37.9	15.3
768L _ 6 X 3/8	6	3/8	4.8	18	31.0	38.4	15.3
768L _ 6 X 1/2	6	1/2	4.8	22	37.3	44.7	15.3
768L _ 8 X 1/8	8	1/8	4.8	15	26.7	34.2	16.2
768L _ 8 X 1/4	8	1/4	6.4	15	31.2	38.7	16.2
768L _ 8 X 3/8	8	3/8	6.4	18	31.8	39.3	16.2
768L _ 8 X 1/2	8	1/2	6.4	22	38.1	45.6	16.2
768L _ 10 X 1/8	10	1/8	4.8	18	28.7	36.3	17.2
768L _ 10 X 1/4	10	1/4	7.9	18	33.3	40.9	17.2
768L _ 10 X 3/8	10	3/8	7.9	18	33.3	40.9	17.2
768L _ 10 X 1/2	10	1/2	7.9	22	38.9	46.5	17.2
768L _ 10 X 3/4	10	3/4	7.9	27	40.4	48.0	17.2
768L _ 12 X 1/8	12	1/8	4.8	22	28.7	38.8	22.8
768L _ 12 X 1/4	12	1/4	7.1	22	33.3	43.4	22.8
768L _ 12 X 3/8	12	3/8	9.5	22	33.3	43.4	22.8
768L _ 12 X 1/2	12	1/2	9.5	22	38.9	49.0	22.8
768L _ 12 X 3/4	12	3/4	9.5	27	40.4	50.5	22.8
768L _ 14 X 1/4	14	1/4	7.1	24	34.0	44.1	24.4
768L _ 14 X 3/8	14	3/8	9.5	24	34.0	44.1	24.4
768L _ 14 X 1/2	14	1/2	11.1	24	38.9	49.0	24.4
768L _ 15 X 1/2	15	1/2	11.9	24	38.9	49.0	24.4
768L _ 16 X 3/8	16	3/8	9.5	24	34.0	44.1	24.4
768L _ 16 X 1/2	16	1/2	11.9	24	38.9	49.0	24.4
768L _ 16 X 3/4	16	3/4	12.7	27	40.4	50.5	24.4
768L _ 18 X 1/2	18	1/2	11.9	27	40.4	50.5	24.4
768L _ 18 X 3/4	18	3/4	15.1	27	40.4	50.5	24.4
768L _ 20 X 1/2	20	1/2	11.9	30	42.2	52.3	26.0
768L _ 20 X 3/4	20	3/4	15.9	30	42.2	52.3	26.0
768L _ 22 X 3/4	22	3/4	15.9	30	42.2	52.3	26.0
768L _ 22 X 1	22	1	18.3	35	47.0	57.1	26.0
768L _ 25 X 1/2	25	1/2	11.9	35	45.2	57.5	31.3
768L _ 25 X 3/4	25	3/4	15.9	35	45.2	57.5	31.3
768L _ 25 X 1	25	1	21.8	35	50.0	62.3	31.3
768L _ 38 X 1 1/2	*38	1 1/2	33.7	55	64.0	91.6	49.4
768L _ 50 X 2"	*50	2	45.2	3 inch	76.2	113.3	65.0

* Supplied assembled with Nuts and Ferrules. Low friction paste, See page 89
 "D" - Dimension is minimum opening. Dimensions are for reference only, and are subject to change without notice.

Cont'd next page

768 L
MALE CONNECTOR (Cont'd)

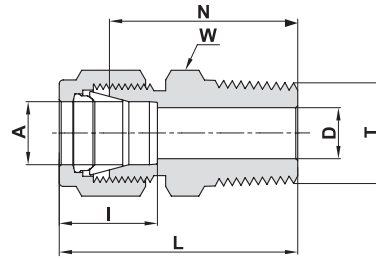

TUBE (INCH) MALE NPT THREAD

Ordering Information	A Tube O.D.		T (NPT)	D		W Hex. Flat	N		L		I	
	inch	mm	inch	inch	mm	inch	inch	mm	inch	mm	inch	mm
768L_ 1/16 X 1/16	1/16	1.58	1/16	.05	1.27	5/16	.79	20.10	.94	23.88	.34	8.6
768L_ 1/16 X 1/8	1/16	1.58	1/8	.05	1.27	7/16	.88	22.35	1.03	26.10	.34	8.6
768L_ 1/16 X 1/4	1/16	1.58	1/4	.05	1.27	9/16	1.07	27.17	1.22	30.98	.34	8.6
768L_ 1/8 X 1/16	1/8	3.17	1/16	.09	2.28	7/16	.91	23.11	1.17	29.71	.50	12.7
768L_ 1/8 X 1/8	1/8	3.17	1/8	.09	2.28	7/16	.94	23.90	1.20	30.48	.50	12.7
768L_ 1/8 X 1/4	1/8	3.17	1/4	.09	2.28	9/16	1.14	28.95	1.40	35.56	.50	12.7
768L_ 1/8 X 3/8	1/8	3.17	3/8	.09	2.28	11/16	1.15	29.21	1.41	35.81	.50	12.7
768L_ 1/8 X 1/2	1/8	3.17	1/2	.09	2.28	7/8	1.40	35.56	1.66	42.16	.50	12.7
768L_ 3/16 X 1/8	3/16	4.76	1/8	.12	3.04	7/16	.97	24.63	1.23	31.24	.54	13.7
768L_ 3/16 X 1/4	3/16	4.76	1/4	.12	3.04	9/16	1.17	29.72	1.43	36.32	.54	13.7
768L_ 1/4 X 1/16	1/4	6.35	1/16	.12	3.04	1/2	1.00	25.40	1.29	32.76	.60	15.2
768L_ 1/4 X 1/8	1/4	6.35	1/8	.19	4.82	1/2	1.00	25.40	1.29	32.76	.60	15.2
768L_ 1/4 X 1/4	1/4	6.35	1/4	.19	4.82	9/16	1.20	30.50	1.49	37.85	.60	15.2
768L_ 1/4 X 3/8	1/4	6.35	3/8	.19	4.82	11/16	1.22	30.98	1.51	38.35	.60	15.2
768L_ 1/4 X 1/2	1/4	6.35	1/2	.19	4.82	7/8	1.47	37.34	1.76	44.70	.60	15.2
768L_ 1/4 X 3/4	1/4	6.35	3/4	.19	4.82	1 1/16	1.53	38.86	1.82	46.22	.60	15.2
768L_ 5/16 X 1/8	5/16	7.93	1/8	.19	4.82	9/16	1.05	26.67	1.34	34.03	.64	16.2
768L_ 5/16 X 1/4	5/16	7.93	1/4	.25	6.35	9/16	1.23	31.24	1.52	38.60	.64	16.2
768L_ 5/16 X 3/8	5/16	7.93	3/8	.25	6.35	11/16	1.25	31.75	1.54	39.11	.64	16.2
768L_ 3/8 X 1/8	3/8	9.52	1/8	.19	4.82	5/8	1.10	27.90	1.39	35.30	.66	16.8
768L_ 3/8 X 1/4	3/8	9.52	1/4	.28	7.11	5/8	1.28	32.51	1.57	39.87	.66	16.8
768L_ 3/8 X 3/8	3/8	9.52	3/8	.28	7.11	11/16	1.28	32.51	1.57	39.87	.66	16.8
768L_ 3/8 X 1/2	3/8	9.52	1/2	.28	7.11	7/8	1.53	38.90	1.82	46.23	.66	16.8
768L_ 3/8 X 3/4	3/8	9.52	3/4	.28	7.11	1 1/16	1.59	40.38	1.88	47.75	.66	16.8
768L_ 3/8 X 1	3/8	9.52	1	.28	7.11	1 3/8	1.85	46.99	2.14	54.35	.66	16.8
768L_ 1/2 X 1/8	1/2	12.70	1/8	.19	4.82	13/16	1.13	28.70	1.53	38.86	.90	22.9
768L_ 1/2 X 1/4	1/2	12.70	1/4	.28	7.11	13/16	1.31	33.27	1.71	43.43	.90	22.9
768L_ 1/2 X 3/8	1/2	12.70	3/8	.38	9.65	13/16	1.31	33.27	1.71	43.43	.90	22.9
768L_ 1/2 X 1/2	1/2	12.70	1/2	.41	10.41	7/8	1.53	38.90	1.93	49.02	.90	22.9
768L_ 1/2 X 3/4	1/2	12.70	3/4	.41	10.41	1 1/16	1.59	40.38	1.99	50.54	.90	22.9
768L_ 1/2 X 1	1/2	12.70	1	.41	10.41	1 3/8	1.85	47.00	2.25	57.15	.90	22.9

Reference Specifications:

- 60° Thread angle
- Pitch measured in inches
- Truncation of root and crest is flat
- Taper angle 1° 47'

American Standard Pipe Thread (NPT).
 NPT (National Pipe Tapered) is made to specifications outlined in ANSI B1.20.1.

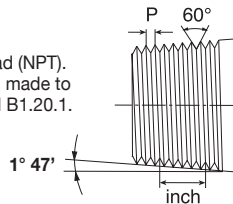

Thermoelement (See Page 38)

"D" - Dimension is minimum opening. Dimensions are for reference only, and are subject to change without notice.

Cont'd next page

768 L
MALE CONNECTOR (Cont'd)

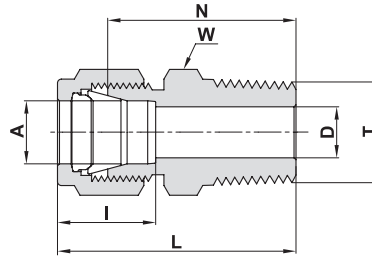

TUBE (INCH) MALE NPT THREAD

Ordering Information	A Tube O.D.		T (NPT)	D		W Hex. Flat	N		L		I	
	inch	mm	inch	inch	mm	inch	inch	mm	inch	mm	inch	mm
768L _ 5/8 X 1/4	5/8	15.87	1/4	.28	7.11	15/16	1.34	34.03	1.74	44.19	.96	24.4
768L _ 5/8 X 3/8	5/8	15.87	3/8	.38	9.65	15/16	1.34	34.03	1.74	44.19	.96	24.4
768L _ 5/8 X 1/2	5/8	15.87	1/2	.47	11.90	15/16	1.53	38.86	1.93	49.02	.96	24.4
768L _ 5/8 X 3/4	5/8	15.87	3/4	.50	12.70	1 1/16	1.59	40.38	1.99	50.54	.96	24.4
768L _ 3/4 X 3/8	3/4	19.05	3/8	.38	9.50	1 1/16	1.38	35.05	1.78	45.21	.96	24.4
768L _ 3/4 X 1/2	3/4	19.05	1/2	.47	11.90	1 1/16	1.59	40.38	1.99	50.54	.96	24.4
768L _ 3/4 X 3/4	3/4	19.05	3/4	.62	15.75	1 1/16	1.59	40.38	1.99	50.54	.96	24.4
768L _ 3/4 X 1	3/4	19.05	1	.62	15.75	1 3/8	1.85	47.00	2.25	57.15	.96	24.4
768L _ 7/8 X 1/2	7/8	22.22	1/2	.47	11.90	1 3/16	1.59	40.38	1.99	50.54	1.02	25.9
768L _ 7/8 X 3/4	7/8	22.22	3/4	.62	15.75	1 3/16	1.59	40.38	1.99	50.54	1.02	25.9
768L _ 7/8 X 1	7/8	22.22	1	.72	18.28	1 3/8	1.85	46.99	2.25	57.15	1.02	25.9
768L _ 1 X 1/2	1	25.40	1/2	.47	11.90	1 3/8	1.78	45.21	2.26	57.40	1.23	31.2
768L _ 1 X 3/4	1	25.40	3/4	.62	15.75	1 3/8	1.78	45.21	2.26	57.40	1.23	31.2
768L _ 1 X 1	1	25.40	1	.88	22.35	1 3/8	1.97	50.03	2.45	62.23	1.23	31.2
768L _ 1 1/4 X 1	*1 1/4	31.75	1	.86	21.80	1 3/4	2.17	55.12	3.04	77.22	1.62	41.2
768L _ 1 1/4 X 1 1/4	*1 1/4	31.75	1 1/4	1.09	27.70	1 3/4	2.17	55.12	3.04	77.22	1.62	41.2
768L _ 1 1/2 X 1 1/2	*1 1/2	38.10	1 1/2	1.34	34.00	2 1/8	2.43	61.72	3.50	88.90	1.97	50.0
768L _ 2 X 2	*2	50.80	2	1.81	45.97	2 3/4	3.00	76.20	4.47	113.54	2.66	67.6

* Including low friction paste, See page 89

Reference Specifications:

- 60° Thread angle
- Pitch measured in inches
- Truncation of root and crest is flat
- Taper angle 1° 47'

American Standard Pipe Thread (NPT).
 NPT (National Pipe Tapered) is made to specifications outlined in ANSI B1.20.1.

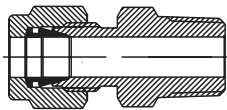
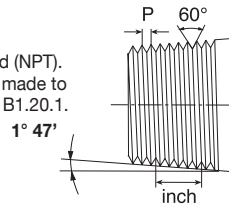

Thermoelement

For ordering: use catalog number of the selected fitting and add the suffix TC.
 Example: 768 L SS 1/4 x 1/4 TC

"D" - Dimension is minimum opening. Dimensions are for reference only, and are subject to change without notice.

768 LR MALE CONNECTOR

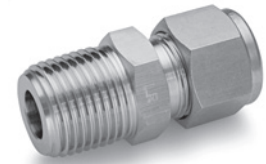
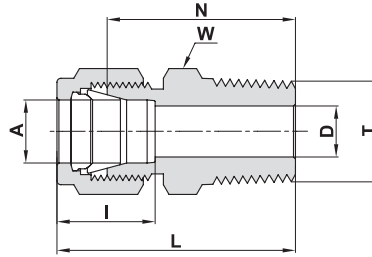

TUBE (METRIC) ISO TAPERED THREAD

Ordering Information	A Tube O.D.	T (ISO)	D	W Hex. Flat	N	L	I
	mm	inch	mm	mm	mm	mm	mm
768LR _ 2 X 1/8	2	R-1/8	1.7	12	23.9	30.5	12.9
768LR _ 3 X 1/8	3	R-1/8	2.4	12	23.9	30.5	12.9
768LR _ 3 X 1/4	3	R-1/4	2.4	14	29.0	35.6	12.9
768LR _ 4 X 1/8	4	R-1/8	2.4	12	24.6	31.2	13.7
768LR _ 4 X 1/4	4	R-1/4	2.4	14	29.7	36.3	13.7
768LR _ 6 X 1/8	6	R-1/8	4.8	14	25.4	32.8	15.3
768LR _ 6 X 1/4	6	R-1/4	4.8	14	30.5	37.9	15.3
768LR _ 6 X 3/8	6	R-3/8	4.8	18	31.0	38.4	15.3
768LR _ 8 X 1/2	6	R-1/2	4.8	22	37.3	44.7	15.3
768LR _ 8 X 1/8	8	R-1/8	4.8	15	26.7	34.2	16.2
768LR _ 8 X 1/4	8	R-1/4	6.4	15	31.2	38.7	16.2
768LR _ 8 X 3/8	8	R-3/8	6.4	18	31.8	39.2	16.2
768LR _ 8 X 1/2	8	R-1/2	6.4	22	38.1	45.6	16.2
768LR _ 10 X 1/8	10	R-1/8	4.8	18	28.7	36.3	17.2
768LR _ 10 X 1/4	10	R-1/4	7.9	18	33.3	40.9	17.2
768LR _ 10 X 3/8	10	R-3/8	7.9	18	33.3	40.9	17.2
768LR _ 10 X 1/2	10	R-1/2	7.9	22	38.9	46.5	17.2
768LR _ 10 X 3/4	10	R-3/4	7.9	27	40.4	48.0	17.2
768LR _ 12 X 1/4	12	R-1/4	7.1	22	33.3	43.4	22.8
768LR _ 12 X 3/8	12	R-3/8	9.5	22	33.3	43.4	22.8
768LR _ 12 X 1/2	12	R-1/2	9.5	22	38.9	49.0	22.8
768LR _ 12 X 3/4	12	R-3/4	9.5	27	40.4	50.5	22.8
768LR _ 14 X 1/4	14	R-1/4	7.1	24	34.0	44.1	24.4
768LR _ 14 X 3/8	14	R-3/8	9.5	24	34.0	44.1	24.4
768LR _ 15 X 1/2	15	R-1/2	11.9	24	38.9	49.0	24.4
768LR _ 16 X 1/4	16	R-1/4	7.1	24	34.0	44.1	24.4
768LR _ 16 X 3/8	16	R-3/8	9.5	24	34.0	44.1	24.4
768LR _ 16 X 1/2	16	R-1/2	11.9	24	38.9	49.0	24.4
768LR _ 16 X 3/4	16	R-3/4	12.7	27	40.4	50.5	24.4
768LR _ 18 X 1/2	18	R-1/2	11.9	27	40.4	50.5	24.4
768LR _ 18 X 3/4	18	R-3/4	15.1	27	40.4	50.5	24.4
768LR _ 20 X 1/2	20	R-1/2	11.9	30	42.2	52.3	26.0
768LR _ 20 X 3/4	20	R-3/4	15.9	30	42.2	52.3	26.0
768LR _ 22 X 3/4	22	R-3/4	15.9	30	42.2	52.3	26.0
768LR _ 22 X 1	22	R-1	18.3	35	47.0	57.1	26.0
768LR _ 25 X 1/2	25	R-1/2	11.9	35	45.2	57.5	31.3
768LR _ 25 X 3/4	25	R-3/4	15.9	35	45.2	57.5	31.3
768LR _ 25 X 1	25	R-1	11.9	35	45.2	57.5	31.3
768LR _ 38 X 1 1/2	*38	R-1 1/2	33.7	55	64.0	91.6	49.4
768LR _ 50 X 2"	*50	R-2	45.2	3 inch	76.2	113.3	65.0

Designation:
Marking LR on Hex

Reference Specifications: DIN -ISO 2999
BS - 21
JIS - B0203
ISO - 7/1-BSP-T

Thermoelement
(See Page 38)

* Including low friction paste, See page 89
"D" - Dimension is minimum opening.
Dimensions are for reference only, and are
subject to change without notice.

768 LR
MALE CONNECTOR (cont'd)

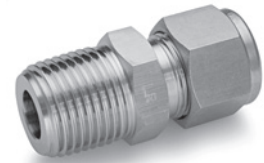
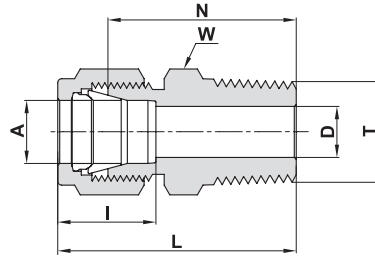

TUBE (INCH) ISO TAPERED THREAD

Ordering Information	A Tube O.D.		T (ISO)	D		W Hex. Flat	N		L		I	
	inch	mm	inch	inch	mm	inch	inch	mm	inch	mm	inch	mm
768LR_ 1/8 X 1/8	1/8	3.17	R-1/8	.09	2.28	7/16	.94	23.90	1.20	30.48	.50	12.70
768LR_ 1/8 X 1/4	1/8	3.17	R-1/4	.09	2.28	9/16	1.14	28.95	1.40	35.56	.50	12.70
768LR_ 1/4 X 1/8	1/4	6.35	R-1/8	.19	4.82	1/2	1.00	25.40	1.29	32.76	.60	15.20
768LR_ 1/4 X 1/4	1/4	6.35	R-1/4	.19	4.82	9/16	1.20	30.50	1.49	37.85	.60	15.20
768LR_ 1/4 X 3/8	1/4	6.35	R-3/8	.19	4.82	11/16	1.22	30.98	1.51	38.35	.60	15.20
768LR_ 1/4 X 1/2	1/4	6.35	R-1/2	.19	4.82	7/8	1.47	37.34	1.76	44.70	.60	15.20
768LR_ 5/16 X 1/8	5/16	7.93	R-1/8	.19	4.82	9/16	1.05	26.67	1.34	34.03	.64	16.20
768LR_ 5/16 X 1/4	5/16	7.93	R-1/4	.25	6.35	9/16	1.23	31.24	1.52	38.60	.64	16.20
768LR_ 3/8 X 1/8	3/8	9.52	R-1/8	.19	4.82	5/8	1.10	27.90	1.39	35.30	.66	16.80
768LR_ 3/8 X 1/4	3/8	9.52	R-1/4	.28	7.11	5/8	1.28	32.51	1.57	39.87	.66	16.80
768LR_ 3/8 X 3/8	3/8	9.52	R-3/8	.28	7.11	11/16	1.28	32.51	1.57	39.87	.66	16.80
768LR_ 3/8 X 1/2	3/8	9.52	R-1/2	.28	7.11	7/8	1.53	38.90	1.82	46.23	.66	16.80
768LR_ 3/8 X 3/4	3/8	9.52	R-3/4	.28	7.11	1 1/16	1.59	40.38	1.88	47.75	.66	16.80
768LR_ 1/2 X 1/4	1/2	12.70	R-1/4	.28	7.11	13/16	1.31	33.27	1.71	43.43	.90	22.90
768LR_ 1/2 X 3/8	1/2	12.70	R-3/8	.38	9.65	13/16	1.31	33.27	1.71	43.43	.90	22.90
768LR_ 1/2 X 1/2	1/2	12.70	R-1/2	.41	10.41	7/8	1.53	38.90	1.93	49.02	.90	22.90
768LR_ 1/2 X 3/4	1/2	12.70	R-3/4	.41	10.41	1 1/16	1.59	40.38	1.99	50.54	.90	22.90
768LR_ 5/8 X 1/2	5/8	15.87	R-1/2	.47	11.90	15/16	1.53	38.86	1.93	49.02	.96	24.40
768LR_ 3/4 X 3/4	3/4	19.05	R-3/4	.62	15.74	1 1/16	1.59	40.38	1.99	50.54	.96	24.40
768LR_ 3/4 X 1	3/4	19.05	R-1	.62	15.74	1 3/8	1.85	47.00	2.25	57.15	.96	24.40
768LR_ 1 X 3/4	1	25.40	R-3/4	.63	15.90	1 3/8	1.78	45.21	2.26	57.40	1.23	31.20
768LR_ 1 X 1	1	25.40	R-1	.88	22.35	1 3/8	1.97	50.03	2.45	62.23	1.23	31.20
768LR_ 1 1/4 X 1 1/4	*1 1/4	31.75	R-1 1/4	1.09	27.70	1 3/4	2.17	55.12	3.04	77.22	1.62	41.20

* Including low friction paste, See page 89

Reference Specifications:

DIN -ISO 2999
 BS - 21
 JIS - B0203
 ISO - 7/1-BSP-T

55° Thread angle
 Truncation of root and crest is round
 Taper angle 1°47'

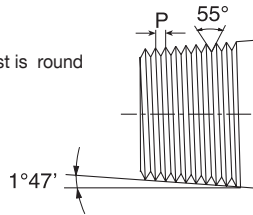

Designation:
 Marking LR on Hex

Thermoelement (See Page 38)

"D" - Dimension is minimum opening. Dimensions are for reference only, and are subject to change without notice.

768 LG MALE CONNECTOR

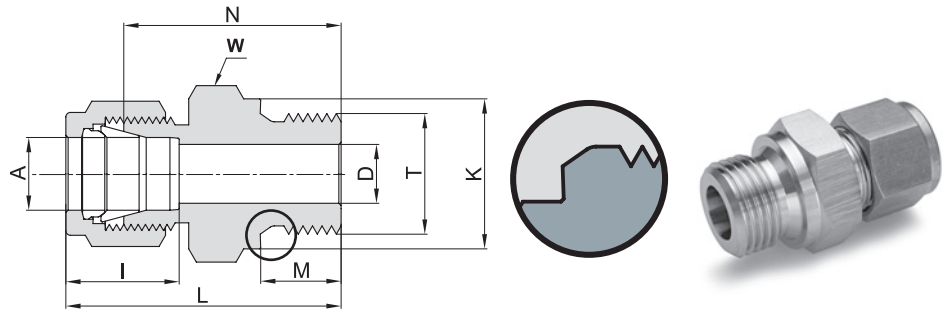

TUBE (METRIC) ISO PARALLEL THREAD

Ordering Information	A	T	D	K	W	N	M	L	I
	Tube O.D. mm	(P-ISO) inch	mm	mm	Hex. Flat mm	mm	mm	mm	mm
768LG _ 2 X 1/8	2	G-1/8	1.7	13.8	14	23.4	7.1	30.0	12.9
768LG _ 3 X 1/8	3	G-1/8	2.4	13.8	14	23.4	7.1	30.0	12.9
768LG _ 3 X 1/4	3	G-1/4	2.4	18.0	19	28.7	11.2	35.3	12.9
768LG _ 4 X 1/8	4	G-1/8	2.4	13.8	14	24.1	7.1	30.7	13.7
768LG _ 6 X 1/8	6	G-1/8	4.0	13.8	14	24.9	7.1	32.3	15.3
768LG _ 6 X 1/4	6	G-1/4	4.8	18.0	19	30.2	11.2	37.6	15.3
768LG _ 6 X 3/8	6	G-3/8	4.8	21.8	22	31.5	11.2	38.9	15.3
768LG _ 6 X 1/2	6	G-1/2	4.8	26.0	27	37.3	14.2	44.7	15.3
768LG _ 8 X 1/8	8	G-1/8	4.0	13.8	15	25.7	7.1	33.2	16.2
768LG _ 8 X 1/4	8	G-1/4	6.4	18.0	19	31.0	11.2	38.5	16.2
768LG _ 8 X 3/8	8	G-3/8	6.4	21.8	22	32.3	11.2	39.8	16.2
768LG _ 8 X 1/2	8	G-1/2	6.4	26.0	27	38.1	14.2	45.6	16.2
768LG _ 10 X 1/4	10	G-1/4	6.4	18.0	19	31.8	11.2	39.4	17.2
768LG _ 10 X 3/8	10	G-3/8	7.9	21.8	22	33.0	11.2	40.6	17.2
768LG _ 10 X 1/2	10	G-1/2	7.9	26.0	27	38.9	14.2	46.5	17.2
768LG _ 12 X 1/4	12	G-1/4	5.9	18.0	22	32.5	11.2	42.6	22.8
768LG _ 12 X 3/8	12	G-3/8	7.9	21.8	22	33.0	11.2	43.1	22.8
768LG _ 12 X 1/2	12	G-1/2	9.5	26.0	27	37.4	14.2	47.5	22.8
768LG _ 12 X 3/4	12	G-3/4	9.5	32.0	35	42.7	15.7	52.8	22.8
768LG _ 14 X 3/8	14	G-3/8	7.9	21.8	24	33.8	11.2	43.9	24.4
768LG _ 14 X 1/2	14	G-1/2	11.1	26.0	27	38.9	14.2	49.0	24.4
768LG _ 15 X 3/8	15	G-3/8	7.9	21.8	24	33.8	11.2	43.9	24.4
768LG _ 15 X 1/2	15	G-1/2	11.9	26.0	27	37.4	14.2	47.5	24.4
768LG _ 15 X 3/4	15	G-3/4	11.9	32.0	35	42.1	15.7	52.8	24.4
768LG _ 16 X 3/8	16	G-3/8	7.9	21.8	24	33.8	11.2	43.9	24.4
768LG _ 16 X 1/2	16	G-1/2	11.9	26.0	27	38.9	14.2	49.0	24.4
768LG _ 16 X 3/4	16	G-3/4	12.7	32.0	35	42.1	15.7	52.8	24.4
768LG _ 18 X 1/2	18	G-1/2	11.9	26.0	27	38.9	14.2	49.0	24.4
768LG _ 18 X 3/4	18	G-3/4	15.1	32.0	35	42.7	15.7	52.8	24.4
768LG _ 20 X 1/2	20	G-1/2	11.9	26.0	30	40.4	14.2	50.5	26.0
768LG _ 20 X 3/4	20	G-3/4	15.9	32.0	35	42.7	15.7	52.8	26.0
768LG _ 22 X 3/4	22	G-3/4	15.9	32.0	35	42.7	15.7	52.8	26.0
768LG _ 22 X 1	22	G-1	18.3	39.0	41	45.2	18.3	55.3	26.0
768LG _ 25 X 3/4	25	G-3/4	15.9	32.0	35	45.2	15.7	57.5	31.3
768LG _ 25 X 1	25	G-1	19.8	39.0	41	47.8	18.3	60.1	31.3
768LG _ 38 X1 1/2	*38	G-1 1/2	31.8	54.7	55	63.2	22.1	90.9	49.4

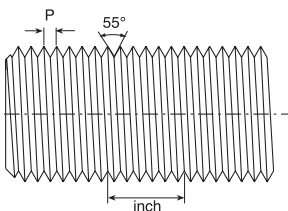

Reference Specifications:

DIN - ISO 228/1
BS - 2779
JIS - B0202
ISO - 228/1-BSP-P

- 55° Thread angle
- Pitch measured in inches
- Truncation of root and crest is round
- Diameter measured in inches

Designation:

Marking LG on Hex.

* Including low friction paste, See page 89.
"D" - Dimension is minimum opening.
Dimensions are for reference only, and are subject to change without notice.

768 LG MALE CONNECTOR

(Cont'd)

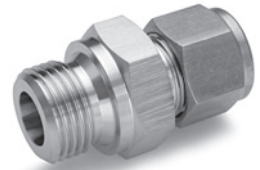
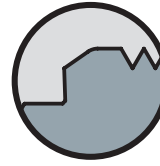
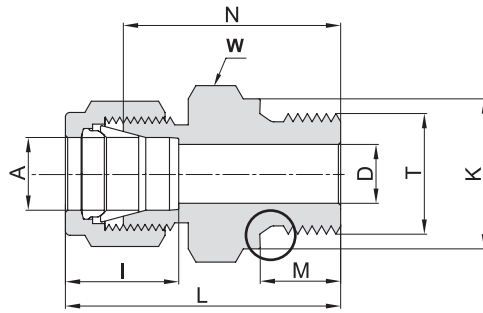

TUBE (INCH) TO ISO PARALLEL THREAD

Ordering Information	A Tube O.D.		T (P-ISO)		D		K		W Hex. Flat	N		M		L		I	
	inch	mm	inch	mm	inch	mm	inch	mm	inch	inch	mm	inch	mm	inch	mm	inch	mm
768LG _ 1/8 X 1/8	1/8	3.17	G-1/8	3.17	0.09	2.30	0.54	13.80	9/16	0.92	23.40	0.28	7.10	1.18	30.00	0.50	12.7
768LG _ 1/8 X 1/4	1/8	3.17	G-1/4	6.35	0.09	2.30	0.71	18.00	3/4	1.13	28.70	0.44	11.20	1.39	35.30	0.50	12.7
768LG _ 1/8 X 3/8	1/8	3.17	G-3/8	9.52	0.09	2.30	0.86	21.80	7/8	1.17	29.72	0.44	11.20	1.43	36.32	0.50	12.7
768LG _ 1/8 X 1/2	1/8	3.17	G-1/2	12.70	0.09	2.30	1.02	26.00	1 1/16	1.40	35.70	0.56	14.20	1.66	42.16	0.50	12.7
768LG _ 3/16 X 1/8	3/16	4.76	G-1/8	3.17	0.12	3.10	0.54	13.80	9/16	0.95	24.10	0.28	7.10	1.21	30.70	0.54	13.7
768LG _ 1/4 X 1/8	1/4	6.35	G-1/8	3.17	0.16	4.10	0.54	13.80	9/16	0.98	24.90	0.28	7.10	1.27	32.26	0.60	15.2
768LG _ 1/4 X 1/4	1/4	6.35	G-1/4	6.35	0.19	4.80	0.71	18.00	3/4	1.19	30.20	0.44	11.20	1.48	37.60	0.60	15.2
768LG _ 1/4 X 3/8	1/4	6.35	G-3/8	9.52	0.19	4.80	0.86	21.80	7/8	1.24	31.50	0.44	11.20	1.50	38.10	0.60	15.2
768LG _ 1/4 X 1/2	1/4	6.35	G-1/2	12.70	0.19	4.80	1.02	26.00	1 1/16	1.47	37.30	0.56	14.20	1.76	44.70	0.60	15.2
768LG _ 5/16 X 1/4	5/16	7.93	G-1/4	6.35	0.25	6.40	0.71	18.00	3/4	1.22	31.00	0.44	11.20	1.51	38.36	0.64	16.2
768LG _ 5/16 X 3/8	5/16	7.93	G-3/8	9.52	0.25	6.40	0.86	21.80	7/8	1.27	32.30	0.44	11.20	1.56	39.66	0.64	16.2
768LG _ 3/8 X 1/8	3/8	9.52	G-1/8	3.17	0.16	4.00	1.26	32.0	5/8	1.05	26.7	0.28	7.10	1.34	34.03	0.66	16.8
768LG _ 3/8 X 1/4	3/8	9.52	G-1/4	6.35	0.23	5.80	0.71	18.00	3/4	1.25	31.75	0.44	11.20	1.54	39.11	0.66	16.8
768LG _ 3/8 X 3/8	3/8	9.52	G-3/8	9.52	0.28	7.10	0.86	21.80	7/8	1.30	33.00	0.44	11.20	1.59	40.40	0.66	16.8
768LG _ 3/8 X 1/2	3/8	9.52	G-1/2	12.70	0.28	7.10	1.02	26.00	1 1/16	1.53	38.86	0.56	14.20	1.82	46.22	0.66	16.8
768LG _ 1/2 X 1/4	1/2	12.70	G-1/4	6.35	0.23	5.80	0.71	18.00	13/16	1.28	32.50	0.44	11.20	1.68	42.67	0.90	22.9
768LG _ 1/2 X 3/8	1/2	12.70	G-3/8	9.52	0.31	7.90	0.86	21.80	7/8	1.30	33.00	0.44	11.20	1.70	43.18	0.90	22.9
768LG _ 1/2 X 1/2	1/2	12.70	G-1/2	12.70	0.41	10.40	1.02	26.00	1 1/16	1.47	37.40	0.56	14.20	1.87	47.56	0.90	22.9
768LG _ 1/2 X 3/4	1/2	12.70	G-3/4	19.05	0.41	10.40	1.26	32.00	1 5/16	1.68	42.70	0.62	15.70	2.08	52.86	0.90	22.9
768LG _ 5/8 X 3/8	5/8	15.87	G-3/8	9.52	0.31	7.90	0.86	21.80	24mm	1.33	33.80	0.44	11.20	1.73	43.96	0.96	24.4
768LG _ 5/8 X 1/2	5/8	15.87	G-1/2	12.70	0.47	11.90	1.02	26.00	1 1/16	1.53	38.90	0.56	14.20	1.93	49.10	0.96	24.4
768LG _ 3/4 X 1/2	3/4	19.05	G-1/2	12.70	0.47	11.90	1.02	26.00	1 1/16	1.53	38.86	0.56	14.20	1.93	49.00	0.96	24.4
768LG _ 3/4 X 3/4	3/4	19.05	G-3/4	19.05	0.62	15.80	1.26	32.00	1 5/16	1.68	42.70	0.62	15.70	2.08	52.83	0.96	24.4
768LG _ 1 X 1/2	1	25.40	G-1/2	12.70	0.47	11.90	1.02	26.00	1 3/8	1.72	43.70	0.56	14.20	2.20	55.80	1.23	31.2
768LG _ 1 X 3/4	1	25.40	G-3/4	19.05	0.62	15.90	1.26	32.00	1 3/8	1.78	45.20	0.62	15.70	2.26	57.40	1.23	31.2
768LG _ 1 X 1	1	25.40	G-1	25.40	0.78	19.80	1.54	39.00	1 5/8	1.88	47.80	0.72	18.30	2.36	59.94	1.23	31.2

Designation:

Marking LG on Hex.

Reference Specifications:

DIN - ISO 228/1
BS - 2779
JIS - B0202
ISO - 228/1-BSP-P

- 55° Thread angle
- Pitch measured in inches
- Truncation of root and crest is round
- Diameter measured in inches

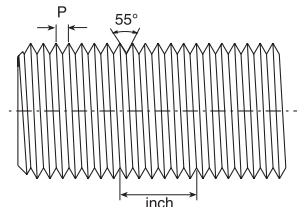

"D" - Dimension is minimum opening. Dimensions are for reference only, and are subject to change without notice.

768 LOK MALE CONNECTOR

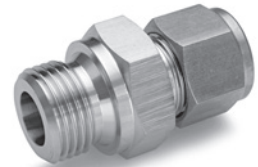
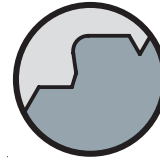
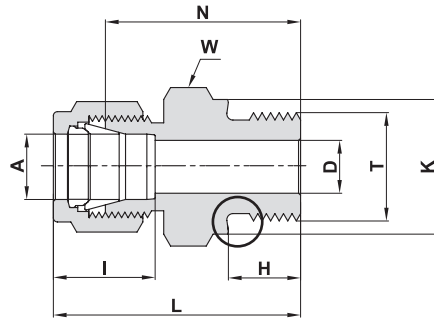

TUBE (METRIC) ISO PARALLEL THREAD

Ordering Information	A	T	D	K	W	N	H	L	I
	Tube O.D. mm	(P-ISO) inch	mm	mm	Hex. Flat mm	mm	mm	mm	mm
768LOK_3 X 1/8	3	G-1/8A	2.4	13.8	14	26.7	7.1	33.3	12.9
768LOK_3 X 1/4	3	G-1/4A	2.4	18.0	19	28.7	11.2	35.3	12.9
768LOK_4 X 1/8	4	G-1/8A	2.4	13.8	14	24.1	7.1	30.7	13.7
768LOK_6 X 1/8	6	G-1/8A	4.0	13.8	14	24.9	7.1	32.3	15.3
768LOK_6 X 1/4	6	G-1/4A	4.8	18.0	19	30.2	11.2	37.6	15.3
768LOK_6 X 3/8	6	G-3/8A	4.8	21.8	22	31.5	11.2	38.9	15.3
768LOK_6 X 1/2	6	G-1/2A	4.8	26.0	27	37.3	14.2	44.7	15.3
768LOK_8 X 1/8	8	G-1/8A	4.0	13.8	15	25.7	7.1	33.2	16.2
768LOK_8 X 1/4	8	G-1/4A	6.4	18.0	19	31.0	11.2	38.5	16.2
768LOK_8 X 3/8	8	G-3/8A	6.4	21.8	22	32.3	11.2	39.8	16.2
768LOK_8 X 1/2	8	G-1/2A	6.4	26.0	27	38.1	14.2	45.6	16.2
768LOK_10 X 1/4	10	G-1/4A	6.4	18.0	19	31.8	11.2	39.4	17.2
768LOK_10 X 3/8	10	G-3/8A	7.9	21.8	22	33.0	11.2	40.6	17.2
768LOK_10 X 1/2	10	G-1/2A	7.9	26.0	27	38.9	14.2	46.5	17.2
768LOK_12 X 1/4	12	G-1/4A	5.9	18.0	22	32.5	11.2	42.6	22.8
768LOK_12 X 3/8	12	G-3/8A	7.9	21.8	22	33.0	11.2	43.1	22.8
768LOK_12 X 1/2	12	G-1/2A	9.5	26.0	27	38.9	14.2	49.0	22.8
768LOK_12 X 3/4	12	G-3/4A	9.5	32.0	35	42.7	15.7	52.8	22.8
768LOK_15 X 1/2	15	G-1/2A	11.9	26.0	27	38.9	14.2	49.0	24.4
768LOK_16 X 3/8	16	G-3/8A	7.9	21.8	24	33.8	11.2	43.9	22.4
768LOK_16 X 1/2	16	G-1/2A	11.9	26.0	27	38.9	14.2	49.0	22.4
768LOK_18 X 1/2	18	G-1/2A	11.9	26.0	27	38.9	14.2	49.0	22.4
768LOK_18 X 3/4	18	G-3/4A	15.1	32.0	35	42.2	15.7	52.3	22.4
768LOK_20 X 1/2	20	G-1/2A	11.9	26.0	30	40.4	14.2	50.5	26.0
768LOK_20 X 3/4	20	G-3/4A	15.9	32.0	35	42.7	15.7	52.8	26.0
768LOK_22 X 3/4	22	G-3/4A	15.9	32.0	35	42.7	15.7	52.8	26.0
768LOK_22 X 1	22	G-1A	18.3	39.0	41	45.2	18.3	55.3	26.0
768LOK_25 X 3/4	25	G-3/4A	15.9	32.0	35	45.2	15.7	57.5	31.3
768LOK_25 X 1	25	G-1A	19.8	39.0	41	47.8	18.3	60.1	31.3
768LOK_38X1/2	*38	G-1 1/2A	31.8	54.7	55	64.9	20.6	92.1	49.4

* Including low friction paste, See page 89

Reference Specifications:

DIN - ISO 228/1
BS - 2779
JIS - B0202
ISO - 228/1-BSP-P

Designation:

Marking LOK on Hex.

"D" - Dimension is minimum opening. Dimensions are for reference only, and are subject to change without notice.

768 LOB MALE CONNECTOR

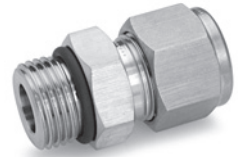
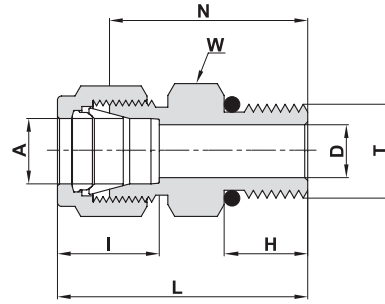

SAE/MS STRAIGHT THREAD BOSS***

Ordering Information	A	T	D	W	N	H	L	I	O-Ring**
	Tube O.D.	Straight Thread UN		Hex. Flat					
	mm	inch	mm	mm	mm	mm	mm	mm	
768LOB_3 X 5/16-24	3	5/16-24	2.4	7/16"	23.4	7.6	30.0	12.9	-902
768LOB_3 X 9/16-18	3	9/16-18	2.4	18	26.7	9.9	33.3	12.9	-906
768LOB_6 X 1/2-20	6	1/2-20	4.8	17	27.4	9.1	34.8	15.3	-905
768LOB_6 X 9/16-18	6	9/16-18	4.8	18	28.2	9.9	35.6	15.3	-906
768LOB_6 X 7/8-14	6	7/8-14	4.8	27	33.3	12.7	40.7	15.3	-910
768LOB_8 X 1/2-20	8	1/2-20	6.4	17	27.4	9.1	34.9	16.2	-905
768LOB_8 X 9/16-18	8	9/16-18	6.4	18	29.1	9.9	36.6	16.2	-906
768LOB_10 X 9/16-18	10	9/16-18	7.1	18	29.7	9.9	37.3	17.2	-906
768LOB_10 X 3/4-16	10	3/4-16	7.9	22	31.8	11.2	39.4	17.2	-908
768LOB_12 X 7/16-20	12	7/16-20	5.2	22	30.5	9.1	40.6	22.8	-904
768LOB_12 X 9/16-18	12	9/16-18	7.1	22	29.0	9.9	39.1	22.8	-906
768LOB_12 X 3/4-16	12	3/4-16	9.5	22	31.8	11.2	41.9	22.8	-908
768LOB_16 X 9/16-18	16	9/16-18	7.1	24	21.2	9.9	31.3	24.4	-906
768LOB_25 X 1 1/16-12	25	1 1/16-12	16.7	35	41.2	15.0	53.5	31.3	-912

Designation: Marking LOB on Hex.

*** Per SAE J1926 and MS 16142. See page 78 for mounting dimensions.

** O-rings used are Viton 90 Durometer. Other O-ring materials are available on request.

"D" - Dimension is minimum opening. Dimensions are for reference only, and are subject to change without notice.

Cont'd next page

768 LOB MALE CONNECTOR

(Cont'd)

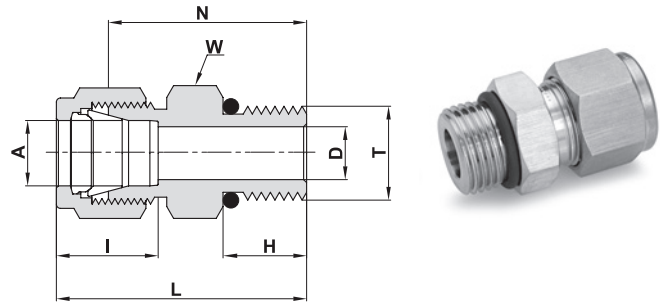

SAE/MS STRAIGHT THREAD BOSS***

Ordering Information	A Tube O.D.		T Straight Thread UN	D		W Hex. Flat	N		H		L		I		O-RING**
	inch	mm	inch	inch	mm	inch	inch	mm	inch	mm	inch	mm	inch	mm	
768LOB_ 1/8 X 5/16-24	1/8	3.17	5/16-24	.09	2.28	7/16	.92	23.37	.30	7.62	1.18	29.97	.50	12.7	-902
768LOB_ 1/8 X 7/16-20	1/8	3.17	7/16-20	.09	2.28	9/16	.98	24.89	.36	9.14	1.24	31.50	.50	12.7	-904
768LOB_ 1/8 X 9/16-18	1/8	3.17	9/16-18	.09	2.28	11/16	1.05	26.67	.39	9.90	1.31	33.27	.50	12.7	-906
768LOB_ 1/4 X 5/16-24	1/4	6.35	5/16-24	.09	2.28	9/16	.92	23.37	.30	7.62	1.21	30.73	.60	15.2	-902
768LOB_ 1/4 X 7/16-20	1/4	6.35	7/16-20	.19	4.82	9/16	1.05	26.67	.36	9.14	1.34	34.03	.60	15.2	-904
768LOB_ 1/4 X 9/16-18	1/4	6.35	9/16-18	.19	4.82	11/16	1.11	28.19	.39	9.90	1.40	35.56	.60	15.2	-906
768LOB_ 1/4 X 3/4 -16	1/4	6.35	3/4 -16	.19	4.82	7/8	1.19	30.20	.44	11.17	1.48	37.59	.60	15.2	-908
768LOB_ 1/4 X 7/8-14	1/4	6.35	7/8-14	.19	4.82	1	1.31	33.27	.50	12.70	1.60	40.64	.60	15.2	-910
768LOB_ 5/16 X 1/2-20	5/16	7.93	1/2-20	.25	6.40	5/8	1.08	27.43	.36	9.14	1.37	34.80	.64	16.2	-905
768LOB_ 3/8 X 7/16-20	3/8	9.52	7/16-20	.20	5.10	5/8	1.11	28.19	.36	9.14	1.40	35.56	.66	16.8	-904
768LOB_ 3/8 X 9/16-18	3/8	9.52	9/16-18	.28	7.11	11/16	1.17	29.71	.39	9.90	1.46	37.02	.66	16.8	-906
768LOB_ 3/8 X 3/4 -16	3/8	9.52	3/4 -16	.28	7.11	7/8	1.25	31.75	.44	11.17	1.54	39.11	.66	16.8	-908
768LOB_ 3/8 X 7/8-14	3/8	9.52	7/8-14	.28	7.11	1	1.37	34.80	.50	12.70	1.66	42.16	.66	16.8	-910
768LOB_ 1/2 X 9/16-18	1/2	12.70	9/16-18	.28	7.11	13/16	1.14	28.95	.39	9.90	1.54	39.11	.90	22.9	-906
768LOB_ 1/2 X 3/4 -16	1/2	12.70	3/4 -16	.41	10.41	7/8	1.25	31.75	.44	11.17	1.65	41.91	.90	22.9	-908
768LOB_ 1/2 X 7/8-14	1/2	12.70	7/8-14	.41	10.41	1	1.37	34.80	.50	12.70	1.77	44.96	.90	22.9	-910
768LOB_ 1/2 X 1 1/16-12	1/2	12.70	1 1/16-12	.41	10.41	1 1/4	1.53	38.86	.59	14.98	1.93	49.02	.90	22.9	-912
768LOB_ 5/8 X 3/4 -16	5/8	15.87	3/4 -16	.42	10.66	15/16	1.25	31.75	.44	11.17	1.65	41.91	.96	22.4	-908
768LOB_ 5/8 X 7/8 -14	5/8	15.87	7/8 -14	.50	12.70	1	1.38	35.05	.50	12.70	1.78	45.21	.96	22.4	-910
768LOB_ 3/4 X 3/4 -16	3/4	19.05	3/4 -16	.42	10.66	1 1/16	1.41	35.81	.44	11.17	1.81	46.0	.96	22.4	-908
768LOB_ 3/4 X 1 1/16 -12	3/4	19.05	1 1/16 -12	.62	15.74	1 1/4	1.53	38.86	.59	14.98	1.93	49.02	.96	22.4	-912
768LOB_ 3/4 X 1 5/16-12	3/4	19.05	1 5/16-12	.62	15.74	1 1/2	1.66	42.16	.59	14.98	2.06	52.32	1.02	25.9	-916
768LOB_ 7/8 X 1 3/16 -12	7/8	22.22	1 3/16 -12	.72	18.29	1 3/8	1.53	38.86	.59	14.98	1.93	49.02	1.02	25.9	-914
768LOB_ 1 X 1 1/16 -12	1	25.40	1 1/16 -12	.66	16.76	1 3/8	1.62	41.20	.59	14.98	2.10	53.34	1.23	31.2	-912
768LOB_ 1 X 1 5/16 -12	1	25.40	1 5/16 -12	.88	22.35	1 1/2	1.66	42.16	.59	14.98	2.14	54.35	1.23	31.2	-916
768LOB_ 1 1/4 X 1 5/8 -12	*1 1/4	31.75	1 5/8 -12	1.09	27.70	1 7/8	1.82	46.23	.59	15.10	2.69	68.33	1.62	41.2	-920
768LOB_ 1 1/2 X 1 7/8 -12	*1 1/2	38.10	1 7/8 -12	1.34	34.00	2 1/8	1.99	50.55	.59	15.10	3.06	77.72	1.97	50.0	-924
768LOB_ 2 X 2 1/2 -12	*2	50.80	2 1/2 -12	1.81	45.97	2 3/4	2.53	64.26	.59	15.10	4.00	101.60	2.66	67.6	-932

Designation: Marking LOB on Hex.

*** Per SAE J1926 and MS 16142. See page 78 for mounting dimensions.

** O-rings used are Viton 90 Durometer. Other O-ring materials are available on request.

* Including low friction paste, See page 89

"D" - Dimension is minimum opening. Dimensions are for reference only, and are subject to change without notice.

768 LOP MALE CONNECTOR

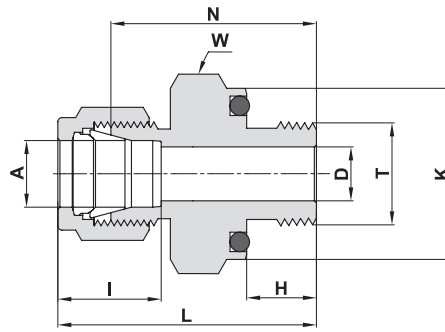

O-SEAL NPT TAPERED THREAD

Ordering Information	A Tube O.D.		T (NPT) Short	D Hex. Flat		K		W Hex. Flat		N		H		L		I	O-RING**
	inch	mm	inch	inch	mm	inch	mm	inch	mm	inch	mm	inch	mm	inch	mm	inch	
768LOP_ 1/8 X 1/8	1/8	3.17	1/8	.09	2.28	.74	18.79	3/4	1.03	26.16	.28	7.11	1.29	32.76	.50	12.7	-111
768LOP_ 1/4 X 1/8	1/4	6.35	1/8	.19	4.82	.74	18.79	3/4	1.09	27.70	.28	7.11	1.38	35.05	.60	15.2	-111
768LOP_ 1/4 X 1/4	1/4	6.35	1/4	.19	4.82	.93	23.62	15/16	1.22	31.00	.38	9.65	1.51	38.40	.60	15.2	-113
768LOP_ 3/8 X 1/4	3/8	9.52	1/4	.28	7.11	.93	23.62	15/16	1.28	32.51	.38	9.65	1.57	39.88	.66	16.8	-113
768LOP_ 3/8 X 3/8	3/8	9.52	3/8	.28	7.11	1.12	28.45	1 1/8	1.34	34.04	.41	10.41	1.63	41.40	.66	16.8	-116
768LOP_ 3/8 X 1/2	3/8	9.52	1/2	.28	7.11	1.30	33.02	1 5/16	1.56	39.62	.53	13.46	1.85	46.99	.66	16.8	-212
768LOP_ 1/2 X 1/2	1/2	12.70	1/2	.41	10.41	1.30	33.02	1 5/16	1.56	39.62	.53	13.46	1.96	49.78	.90	22.9	-212

Designation: Marking LOP on Hex.

** O-rings used are BUNA 70 Durometer.

768 LO MALE CONNECTOR

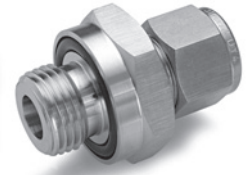
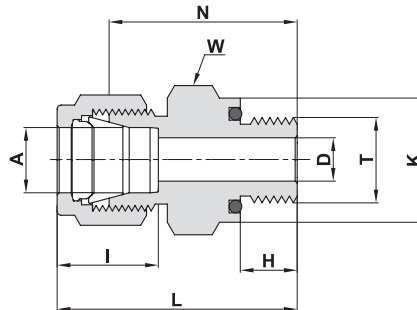

O-SEAL MALE UN THREAD

Ordering Information	A Tube O.D.		T Straight Thread UN	D		K		W Hex. Flat		N		H		L		I	O-RING**
	inch	mm	inch	inch	mm	inch	mm	inch	mm	inch	mm	inch	mm	inch	mm	inch	
768LO_ 1/16 X 5/16-24	1/16	1.58	5/16-24	.05	1.27	.55	14.0	9/16	.90	22.86	.34	8.63	1.05	26.67	.34	8.6	-011
768LO_ 1/8 X 5/16-24	1/8	3.17	5/16-24	.09	2.28	.55	14.0	9/16	1.03	26.20	.34	8.63	1.29	32.77	.50	12.7	-011
768LO_ 3/16 X 3/8 -24	3/16	4.76	3/8 -24	.12	3.04	.62	15.75	5/8	1.09	27.70	.38	9.65	1.35	34.29	.54	12.7	-012
768LO_ 1/4 X 7/16-20	1/4	6.35	7/16-20	.19	4.82	.74	18.80	3/4	1.22	31.00	.41	10.41	1.51	38.35	.60	15.2	-111
768LO_ 5/16 X 1/2 -20	5/16	7.93	1/2 -20	.25	6.35	.86	21.84	7/8	1.31	33.30	.44	11.17	1.60	40.64	.64	16.2	-112
768LO_ 3/8 X 9/16-18	3/8	9.52	9/16-18	.28	7.11	.93	23.62	15/16	1.38	35.05	.47	11.93	1.67	40.89	.66	16.8	-113
768LO_ 1/2 X 3/4 -16	1/2	12.70	3/4 -16	.41	10.41	1.12	28.45	1 1/8	1.41	35.81	.47	11.93	1.81	45.77	.90	22.9	-116
768LO_ 3/4 X 1 1/16-12	3/4	19.05	1 1/16-12	.62	15.74	1.49	37.85	1 1/2	1.66	42.20	.56	14.22	2.06	52.32	.96	24.4	-215
768LO_ 1 X 1 5/16-12	1	25.40	1 5/16-12	.88	22.35	1.74	44.20	1 3/4	1.81	45.97	.56	14.22	2.29	58.17	1.23	32.2	-219

Designation: Marking LO on Hex.

** O-rings used are BUNA 70 Durometer.

"D" - Dimension is minimum opening. Dimensions are for reference only, and are subject to change without notice.

768 LN
MALE PIPE WELD
CONNECTOR

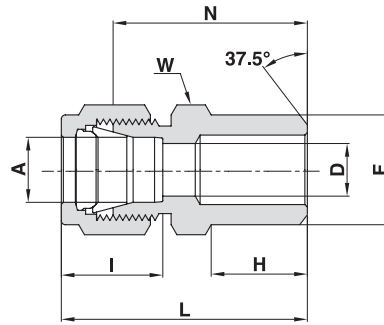

TUBE (METRIC)

Ordering Information	A		F		D	W	N	H	L	I
	Tube O.D.		Pipe Size							
	mm	inch	mm	mm	mm	mm	mm	mm	mm	mm
768LN_ 3 X 1/8	3	1/8	10.30	2.4	12	23.9	9.7	30.5	12.9	
768LN_ 4 X 1/8	4	1/8	10.30	2.4	12	24.6	9.7	31.2	13.7	
768LN_ 6 X 1/8	6	1/8	10.30	4.8	14	25.4	9.7	32.8	15.3	
768LN_ 6 X 1/4	6	1/4	13.70	4.8	14	30.5	14.2	37.9	15.3	
768LN_ 8 X 1/8	8	1/8	10.30	5.1	15	26.7	9.7	34.2	16.2	
768LN_ 8 X 1/4	8	1/4	13.70	6.4	15	31.2	14.2	38.7	16.2	
768LN_ 8 X 1/2	8	1/2	21.34	6.4	22	38.1	19.0	45.6	16.2	
768LN_ 10 X 1/4	10	1/4	13.70	7.1	18	33.3	14.2	40.9	17.2	
768LN_ 10 X 3/8	10	3/8	17.10	7.9	18	33.3	14.2	40.9	17.2	
768LN_ 10 X 1/2	10	1/2	21.34	7.9	22	38.9	19.0	46.5	17.2	
768LN_ 12 X 1/4	12	1/4	13.70	7.1	22	33.3	14.2	43.4	22.8	
768LN_ 12 X 3/8	12	3/8	17.10	9.5	22	33.3	14.2	43.4	22.8	
768LN_ 12 X 1/2	12	1/2	21.34	9.5	22	38.9	19.0	49.0	22.8	
768LN_ 12 X 3/4	12	3/4	26.67	9.5	27	40.4	19.0	50.5	22.8	
768LN_ 14 X 3/8	14	3/8	17.10	10.4	24	34.0	14.2	44.1	24.4	
768LN_ 15 X 1/2	15	1/2	21.34	11.9	24	38.9	19.0	49.0	24.4	
768LN_ 16 X 1/2	16	1/2	21.34	12.7	24	38.9	19.0	49.0	24.4	
768LN_ 18 X 1/2	18	1/2	21.34	13.5	27	40.4	19.0	50.5	24.4	
768LN_ 38 X 1 1/2	*38	1 1/2	48.30	33.7	55	64.0	26.2	91.2	49.4	

Designation: Marking LN on Hex.
 * Including low friction paste, See page 89

"D" - Dimension is minimum opening. Dimensions are for reference only, and are subject to change without notice.

Cont'd next page

768 LN MALE PIPE WELD CONNECTOR

(Cont'd)

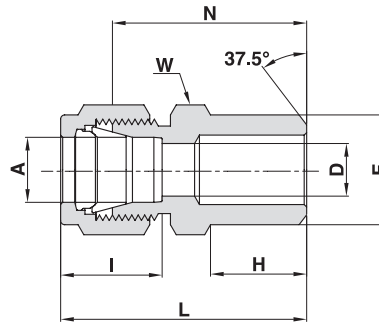

TUBE (INCH)

Ordering Information	A Tube O.D.		F Pipe Size		D		W Hex. Flat	N		H		L		I	
	inch	mm	inch	mm	inch	mm	inch	inch	mm	inch	mm	inch	mm	inch	mm
768LN _ 1/8 X 1/8	1/8	3.17	1/8	10.30	.09	2.28	7/16	.94	23.88	.38	9.65	1.20	30.48	.50	12.7
768LN _ 3/16 X 1/8	3/16	4.76	1/8	10.30	.12	3.04	7/16	.97	24.60	.38	9.65	1.23	31.25	.54	13.7
768LN _ 1/4 X 1/8	1/4	6.35	1/8	10.30	.19	4.82	1/2	1.00	25.40	.38	9.65	1.29	32.77	.60	15.2
768LN _ 1/4 X 1/4	1/4	6.35	1/4	13.70	.19	4.82	9/16	1.20	30.48	.56	14.22	1.49	37.85	.60	15.2
768LN _ 5/16 X 1/8	5/16	7.93	1/8	10.30	.20	5.08	9/16	1.05	26.67	.38	9.65	1.34	34.04	.64	16.2
768LN _ 5/16 X 1/4	5/16	7.93	1/4	13.70	.25	6.35	9/16	1.23	31.24	.56	14.22	1.52	38.61	.64	16.2
768LN _ 3/8 X 1/4	3/8	9.52	1/4	13.70	.28	7.11	5/8	1.28	32.51	.56	14.22	1.57	39.87	.66	16.8
768LN _ 3/8 X 3/8	3/8	9.52	3/8	17.10	.28	7.11	11/16	1.28	32.51	.56	14.22	1.57	39.87	.66	16.8
768LN _ 3/8 X 1/2	3/8	9.52	1/2	21.34	.28	7.11	7/8	1.53	38.86	.75	19.05	1.82	46.22	.66	16.8
768LN _ 3/8 X 3/4	3/8	9.52	3/4	26.67	.28	7.11	1 1/16	1.59	40.38	.75	19.05	1.88	47.75	.66	16.8
768LN _ 1/2 X 3/8	1/2	12.70	3/8	17.10	.41	10.41	13/16	1.31	33.27	.56	14.22	1.71	44.43	.90	22.9
768LN _ 1/2 X 1/2	1/2	12.70	1/2	21.34	.41	10.41	7/8	1.53	38.86	.75	19.05	1.93	49.00	.90	22.9
768LN _ 1/2 X 3/4	1/2	12.70	3/4	26.67	.41	10.41	1 1/16	1.59	40.40	.75	19.05	1.99	50.55	.90	22.9
768LN _ 1/2 X 1	1/2	12.70	1	33.40	.41	10.41	1 3/8	1.87	47.50	.94	23.87	2.27	57.65	.90	22.9
768LN _ 5/8 X 1/2	5/8	15.87	1/2	21.34	.50	12.70	15/16	1.53	38.86	.75	19.05	1.93	49.02	.96	24.4
768LN _ 3/4 X 1/2	3/4	19.05	1/2	21.34	.53	13.46	1 1/16	1.53	38.86	.75	19.05	1.93	49.00	.96	24.4
768LN _ 3/4 X 3/4	3/4	19.05	3/4	26.67	.62	15.74	1 1/16	1.59	40.40	.75	19.05	1.99	50.55	.96	24.4
768LN _ 1 X 1	1	25.40	1	33.40	.88	22.35	1 3/8	1.97	50.03	.94	23.87	2.45	62.23	1.23	31.2
768LN _ 1 1/4 X 1 1/4	*1 1/4	31.75	1 1/4	42.16	1.09	27.70	1 3/4	2.17	55.12	.94	23.88	3.04	77.22	1.62	41.2
768LN _ 1 1/2 X 1 1/2	*1 1/2	38.10	1 1/2	48.26	1.34	34.00	2 1/8	2.43	61.72	1.03	26.16	3.50	88.90	1.97	50.0
768LN _ 2 X 2	*2	50.80	2	60.33	1.81	45.97	2 3/4	3.00	76.20	1.06	26.92	4.47	113.34	2.66	67.6

Designation: Marking LN on Hex.

768 LW TUBE SOCKET WELD UNION

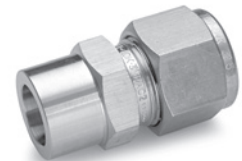
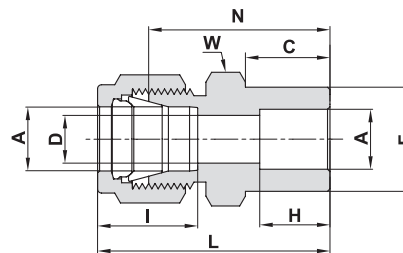

TUBE (INCH)

Ordering Information	A Tube O.D.		C		D		W Hex. Flat	F		H		I		L		N	
	inch	mm	inch	mm	inch	mm	inch	inch	mm	inch	mm	inch	mm	inch	mm	inch	mm
768LW _ 1/8 X 1/8	1/8	3.17	.34	8.64	.09	2.28	7/16	.31	7.87	.25	6.35	.50	12.70	1.14	28.96	.88	22.35
768LW _ 1/4 X 1/4	1/4	6.35	.41	10.41	.19	4.80	1/2	.44	11.18	.31	7.90	.60	15.20	1.32	33.53	1.03	26.16
768LW _ 3/8 X 3/8	3/8	9.52	.47	11.94	.28	7.10	5/8	.62	15.75	.38	9.65	.66	16.80	1.48	37.60	1.19	30.23
768LW _ 1/2 X 1/2	1/2	12.70	.47	11.94	.41	10.40	13/16	.75	19.05	.50	12.70	.90	22.90	1.62	41.15	1.22	31.00
768LW _ 3/4 X 3/4	3/4	19.05	.47	11.94	.62	15.80	1 1/16	1.05	26.67	.56	14.20	.96	24.40	1.71	43.43	1.31	33.28
768LW _ 1 X 1	1	25.40	.56	14.22	.88	22.35	1 3/8	1.36	34.54	.75	19.05	1.23	31.20	2.07	52.58	1.59	40.40

Designation: Marking LW on Hex.

"D" - Dimension is minimum opening. Dimensions are for reference only, and are subject to change without notice.

**769 L
MALE ELBOW**

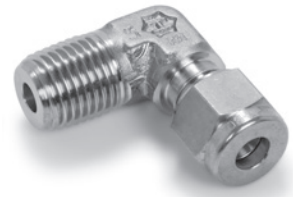
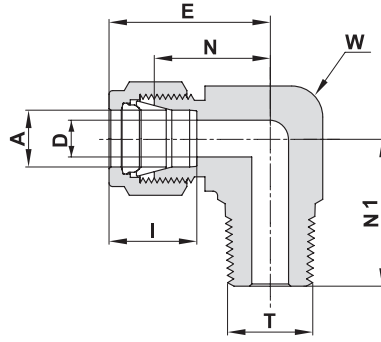

TUBE (METRIC) MALE NPT THREAD

Ordering Information	A	T	D	W		N	E	N1	I
	Tube O.D.	(NPT)		Wrench Flat					
	mm	inch	mm	inch	mm	mm	mm	mm	mm
769L_3 X 1/8	3	1/8	2.4	7/16	11.1	17.0	23.6	17.8	12.9
769L_3 X 1/4	3	1/4	2.4	1/2	12.7	18.0	24.6	23.4	12.9
769L_4 X 1/8	4	1/8	2.4	1/2	12.7	18.8	25.4	18.8	13.7
769L_4 X 1/4	4	1/4	2.4	1/2	12.7	18.8	25.4	23.4	13.7
769L_6 X 1/8	6	1/8	4.8	1/2	12.7	19.6	27.0	18.8	15.3
769L_6 X 1/4	6	1/4	4.8	1/2	12.7	19.6	27.0	23.4	15.3
769L_6 X 3/8	6	3/8	4.8	11/16	17.5	22.4	29.8	26.2	15.3
769L_6 X 1/2	6	1/2	4.8	13/16	20.6	24.4	31.8	33.0	15.3
769L_8 X 1/8	8	1/8	4.8	9/16	14.3	21.3	28.8	19.8	16.2
769L_8 X 1/4	8	1/4	6.4	9/16	14.3	21.3	28.8	24.4	16.2
769L_8 X 3/8	8	3/8	6.4	11/16	17.5	23.1	30.6	26.2	16.2
769L_8 X 1/2	8	1/2	6.4	13/16	20.6	25.1	32.6	33.0	16.2
769L_10 X 1/8	10	1/8	4.8	11/16	17.5	23.9	31.5	21.6	17.2
769L_10 X 1/4	10	1/4	7.1	11/16	17.5	23.9	31.5	26.2	17.2
769L_10 X 3/8	10	3/8	7.9	11/16	17.5	23.9	31.5	26.2	17.2
769L_10 X 1/2	10	1/2	7.9	13/16	20.6	25.9	33.5	33.0	17.2
769L_12 X 1/8	12	1/8	4.8	13/16	20.6	25.9	36.0	23.6	22.8
769L_12 X 1/4	12	1/4	7.1	13/16	20.6	25.9	36.0	28.2	22.8
769L_12 X 3/8	12	3/8	9.5	13/16	20.6	25.9	36.0	28.2	22.8
769L_12 X 1/2	12	1/2	9.5	13/16	20.6	25.9	36.0	33.0	22.8
769L_12 X 3/4	12	3/4	9.5	1 1/16	27.0	29.7	39.8	36.8	22.8
769L_15 X 1/2	15	1/2	11.9	15/16	23.8	27.9	38.0	35.1	24.4
769L_16 X 3/8	16	3/8	9.5	15/16	23.8	27.9	38.0	30.2	24.4
769L_16 X 1/2	16	1/2	11.9	15/16	23.8	27.9	38.0	35.1	24.4
769L_16 X 3/4	16	3/4	12.7	1 1/16	27.0	29.7	39.8	36.8	24.4
769L_18 X 1/2	18	1/2	11.9	1 1/16	27.0	29.7	39.8	36.8	24.4
769L_18 X 3/4	18	3/4	15.1	1 1/16	27.0	29.7	39.8	36.8	24.4
769L_20 X 1/2	20	1/2	11.9	1 3/8	34.9	34.5	44.6	41.7	26.0
769L_20 X 3/4	20	3/4	15.9	1 3/8	34.9	34.5	44.6	41.7	26.0
769L_22 X 3/4	22	3/4	15.9	1 3/8	34.9	34.5	44.6	41.7	26.0
769L_22 X 1	22	1	18.3	1 3/8	34.9	34.5	44.6	46.5	26.0
769L_25 X 3/4	25	3/4	15.9	1 3/8	34.9	36.8	49.1	41.7	31.3
769L_25 X 1	25	1	21.8	1 3/8	34.9	36.8	49.1	46.5	31.3
769L_38 X 1 1/2	*38	1 1/2	33.7	-	55.0	56.4	84.0	60.4	49.4

* Including low friction paste, See page 89

"D" - Dimension is minimum opening. Dimensions are for reference only, and are subject to change without notice.

769 L MALE ELBOW

(Cont'd)

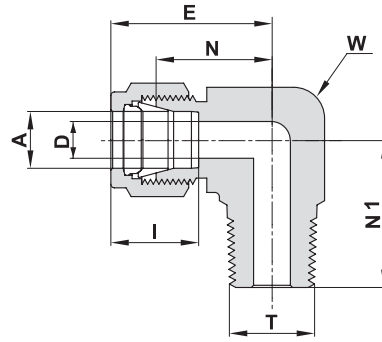

TUBE (INCH) MALE NPT THREAD

Ordering Information	A Tube O.D.		T (NPT)	D		W Wrench Flat		N		E		N1		I	
	inch	mm	inch	inch	mm	inch	mm	inch	mm	inch	mm	inch	mm	inch	mm
769L_ 1/16 X 1/16	1/16	1.58	1/16	.05	1.27	7/16	11.1	.60	15.24	.75	19.05	.70	17.78	.34	8.6
769L_ 1/16 X 1/8	1/16	1.58	1/8	.05	1.27	7/16	11.1	.60	15.24	.75	19.05	.70	17.78	.34	8.6
769L_ 1/8 X 1/16	1/8	3.17	1/16	.09	2.28	7/16	11.1	.67	17.02	.93	23.62	.70	17.78	.50	12.7
769L_ 1/8 X 1/8	1/8	3.17	1/8	.09	2.28	7/16	11.1	.67	17.02	.93	23.62	.70	17.78	.50	12.7
769L_ 1/8 X 1/4	1/8	3.17	1/4	.09	2.28	1/2	12.7	.71	18.03	.97	24.64	.92	23.37	.50	12.7
769L_ 3/16 X 1/8	3/16	4.76	1/8	.12	3.04	1/2	12.7	.74	18.80	1.00	25.40	.74	18.80	.54	13.7
769L_ 3/16 X 1/4	3/16	4.76	1/4	.12	3.04	1/2	12.7	.74	18.80	1.00	25.40	.92	23.37	.54	13.7
769L_ 1/4 X 1/16	1/4	6.35	1/16	.12	3.04	1/2	12.7	.77	19.56	1.06	26.92	.74	18.80	.60	15.2
769L_ 1/4 X 1/8	1/4	6.35	1/8	.19	4.82	1/2	12.7	.77	19.56	1.06	26.92	.74	18.80	.60	15.2
769L_ 1/4 X 1/4	1/4	6.35	1/4	.19	4.82	1/2	12.7	.77	19.56	1.06	26.92	.92	23.37	.60	15.2
769L_ 1/4 X 3/8	1/4	6.35	3/8	.19	4.82	11/16	17.5	.88	22.35	1.17	29.71	1.03	26.16	.60	15.2
769L_ 1/4 X 1/2	1/4	6.35	1/2	.19	4.82	13/16	20.6	.96	24.38	1.25	31.75	1.30	33.02	.60	15.2
769L_ 5/16 X 1/8	5/16	7.93	1/8	.19	4.82	9/16	14.3	.84	21.34	1.13	28.70	.78	19.81	.64	16.2
769L_ 5/16 X 1/4	5/16	7.93	1/4	.25	6.35	9/16	14.3	.84	21.34	1.13	28.70	.96	24.38	.64	16.2
769L_ 5/16 X 3/8	5/16	7.93	3/8	.25	6.35	11/16	17.5	.91	23.11	1.20	30.48	1.03	26.16	.64	16.2
769L_ 3/8 X 1/8	3/8	9.52	1/8	.19	4.82	5/8	15.9	.91	23.11	1.20	30.48	.82	20.83	.66	16.8
769L_ 3/8 X 1/4	3/8	9.52	1/4	.28	7.11	5/8	15.9	.91	23.11	1.20	30.48	1.00	25.40	.66	16.8
769L_ 3/8 X 3/8	3/8	9.52	3/8	.28	7.11	11/16	17.5	.94	23.87	1.23	31.24	1.03	26.16	.66	16.8
769L_ 3/8 X 1/2	3/8	9.52	1/2	.28	7.11	13/16	20.6	1.02	25.90	1.31	33.28	1.30	33.02	.66	16.8
769L_ 3/8 X 3/4	3/8	9.52	3/4	.28	7.11	1 1/16	27.0	1.17	29.71	1.46	37.08	1.45	36.83	.66	16.8
769L_ 1/2 X 1/4	1/2	12.70	1/4	.28	7.11	13/16	20.6	1.02	25.90	1.42	36.07	1.11	28.19	.90	22.9
769L_ 1/2 X 3/8	1/2	12.70	3/8	.38	9.50	13/16	20.6	1.02	25.90	1.42	36.07	1.11	28.19	.90	22.9
769L_ 1/2 X 1/2	1/2	12.70	1/2	.41	10.41	13/16	20.6	1.02	25.90	1.42	36.07	1.30	33.02	.90	22.9
769L_ 1/2 X 3/4	1/2	12.70	3/4	.41	10.41	1 1/16	27.0	1.17	29.71	1.57	39.88	1.45	36.83	.90	22.9
769L_ 5/8 X 3/8	5/8	15.87	3/8	.38	9.61	15/16	23.8	1.10	27.94	1.50	38.10	1.19	30.23	.96	24.4
769L_ 5/8 X 1/2	5/8	15.87	1/2	.47	11.94	15/16	23.8	1.10	27.94	1.50	38.10	1.38	35.05	.96	24.4
769L_ 5/8 X 3/4	5/8	15.87	3/4	.50	12.70	1 1/16	27.0	1.17	29.71	1.57	39.88	1.45	36.83	.96	24.4
769L_ 3/4 X 1/2	3/4	19.05	1/2	.47	11.94	1 1/16	27.0	1.17	29.71	1.57	39.88	1.45	36.83	.96	24.4
769L_ 3/4 X 3/4	3/4	19.05	3/4	.62	15.74	1 1/16	27.0	1.17	29.71	1.57	39.88	1.45	36.83	.96	24.4
769L_ 7/8 X 3/4	7/8	22.22	3/4	.62	15.74	1 3/8	34.9	1.36	34.54	1.76	44.70	1.64	41.66	1.02	25.9
769L_ 1 X 3/4	1	25.40	3/4	.62	15.74	1 3/8	34.9	1.45	36.83	1.93	49.02	1.64	41.66	1.23	31.2
769L_ 1 X 1	1	25.40	1	.86	21.84	1 3/8	34.9	1.45	36.83	1.93	49.02	1.83	46.48	1.23	31.2
769L_ 1 1/4 X 1 1/4	*1 1/4	31.75	1 1/4	1.09	27.70	1 11/16	42.9	1.75	44.45	2.62	66.50	1.88	47.75	1.62	41.2
769L_ 1 1/2 X 1 1/2	*1 1/2	38.10	1 1/2	1.34	34.00	2	50.8	2.00	50.80	3.07	78.00	2.38	60.45	1.97	50.0
769L_ 2 X 2	*2	50.80	2	1.81	45.97	2 3/4	69.9	2.75	69.85	4.22	107.19	2.78	70.61	2.66	67.6

* Including low friction paste, See page 89

"D" - Dimension is minimum opening. Dimensions are for reference only, and are subject to change without notice.

**769 LR
MALE ELBOW**

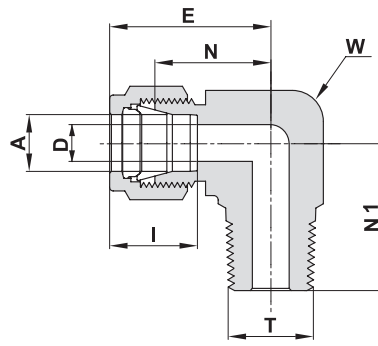

TUBE (METRIC) ISO TAPERED THREAD

Ordering Information	A	T	D	W		N	E	N1	I
	Tube O.D.	(ISO)		Wrench Flat					
	mm	inch	mm	inch	mm	mm	mm	mm	mm
769LR_ 3 X 1/8	3	R-1/8	2.4	7/16	11.1	17.0	23.6	17.8	12.9
769LR_ 3 X 1/4	3	R-1/4	2.4	1/2	12.7	18.0	24.6	23.4	12.9
769LR_ 4 X 1/8	4	R-1/8	2.4	1/2	12.7	18.8	25.4	18.8	13.7
769LR_ 4 X 1/4	4	R-1/4	2.4	1/2	12.7	18.8	25.4	23.4	13.7
769LR_ 6 X 1/8	6	R-1/8	4.8	1/2	12.7	19.6	27.0	18.8	15.3
769LR_ 6 X 1/4	6	R-1/4	4.8	1/2	12.7	19.6	27.0	23.4	15.3
769LR_ 6 X 3/8	6	R-3/8	4.8	11/16	17.5	22.4	29.8	26.2	15.3
769LR_ 6 X 1/2	6	R-1/2	4.8	13/16	20.6	24.4	31.8	33.0	15.3
769LR_ 8 X 1/8	8	R-1/8	4.8	9/16	14.3	21.3	28.8	19.8	16.2
769LR_ 8 X 1/4	8	R-1/4	6.4	9/16	14.3	21.3	28.8	24.4	16.2
769LR_ 8 X 3/8	8	R-3/8	6.4	11/16	17.5	23.1	30.6	26.2	16.2
769LR_ 8 X 1/2	8	R-1/2	6.4	13/16	20.6	25.1	32.6	33.0	16.2
769LR_ 10 X 1/8	10	R-1/8	4.8	11/16	17.5	23.9	31.5	21.6	17.2
769LR_ 10 X 1/4	10	R-1/4	7.1	11/16	17.5	23.9	31.5	26.2	17.2
769LR_ 10 X 3/8	10	R-3/8	7.9	11/16	17.5	23.9	31.5	26.2	17.2
769LR_ 10 X 1/2	10	R-1/2	7.9	13/16	20.6	25.9	33.5	33.0	17.2
769LR_ 12 X 1/8	12	R-1/8	4.8	13/16	20.6	25.9	36.0	23.6	22.8
769LR_ 12 X 1/4	12	R-1/4	7.1	13/16	20.6	25.9	36.0	28.2	22.8
769LR_ 12 X 3/8	12	R-3/8	9.5	13/16	20.6	25.9	36.0	28.2	22.8
769LR_ 12 X 1/2	12	R-1/2	9.5	13/16	20.6	25.9	36.0	33.0	22.8
769LR_ 12 X 3/4	12	R-3/4	9.5	1 1/16	27.0	29.7	39.8	36.8	22.8
769LR_ 14 X 1/2	14	R-1/2	11.0	15/16	23.8	27.9	38.0	35.0	24.4
769LR_ 15 X 1/2	15	R-1/2	11.9	15/16	23.8	27.9	38.0	35.1	24.4
769LR_ 16 X 3/8	16	R-3/8	9.5	15/16	23.8	27.9	38.0	30.2	24.4
769LR_ 16 X 1/2	16	R-1/2	11.9	15/16	23.8	27.9	38.0	35.1	24.4
769LR_ 18 X 1/2	18	R-1/2	11.9	1 1/16	27.0	29.7	39.8	36.8	24.4
769LR_ 18 X 3/4	18	R-3/4	15.1	1 1/16	27.0	29.7	39.8	36.8	24.4
769LR_ 20 X 1/2	20	R-1/2	11.9	1 3/8	34.9	34.5	44.6	41.7	26.0
769LR_ 20 X 3/4	20	R-3/4	15.9	1 3/8	34.9	34.5	44.6	41.7	26.0
769LR_ 22 X 3/4	22	R-3/4	15.9	1 3/8	34.9	34.5	44.6	41.7	26.0
769LR_ 22 X 1	22	R - 1	18.3	1 3/8	34.9	34.5	44.6	46.5	26.0
769LR_ 25 X 3/4	25	R-3/4	15.9	1 3/8	34.9	36.8	49.1	41.7	31.3
769LR_ 25 X 1	25	R - 1	21.8	1 3/8	34.9	36.8	49.1	46.5	31.3

Reference Specifications:

- DIN - 2999
- BS - 21
- JIS - B0203
- ISO - 7/1-BSP-T

Designation:

Marking LR on Flat

"D" - Dimension is minimum opening. Dimensions are for reference only, and are subject to change without notice.

Cont'd next page

769 LR
MALE ELBOW (Cont'd)

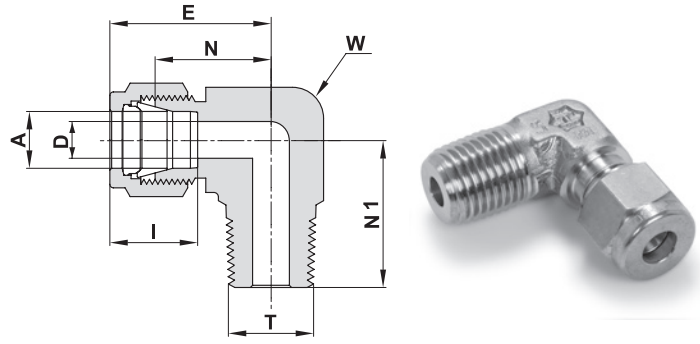

TUBE (INCH) ISO TAPERED THREAD

Ordering Information	A Tube O.D.		T (ISO)	D		W Wrench Flat		N		E		N1		I	
	inch	mm	inch	inch	mm	inch	mm	inch	mm	inch	mm	inch	mm	inch	mm
769LR_ 1/8 X 1/8	1/8	3.17	R-1/8	.09	2.28	7/16	11.1	.67	17.02	.93	23.62	.70	17.78	.50	12.7
769LR_ 1/8 X 1/4	1/8	3.17	R-1/4	.09	2.28	1/2	12.7	.71	18.03	.97	24.64	.92	23.37	.50	12.7
769LR_ 1/4 X 1/8	1/4	6.35	R-1/8	.19	4.82	1/2	12.7	.77	19.56	1.06	26.92	.74	18.80	.60	15.2
769LR_ 1/4 X 1/4	1/4	6.35	R-1/4	.19	4.82	1/2	12.7	.77	19.56	1.06	26.92	.92	23.37	.60	15.2
769LR_ 1/4 X 3/8	1/4	6.35	R-3/8	.19	4.82	11/16	17.5	.88	22.35	1.17	29.71	1.03	26.16	.60	15.2
769LR_ 1/4 X 1/2	1/4	6.35	R-1/2	.19	4.82	13/16	20.6	.96	24.38	1.25	31.75	1.30	33.02	.60	15.2
769LR_ 5/16 X 1/4	5/16	7.93	R-1/4	.25	6.35	9/16	14.3	.84	21.34	1.13	28.70	.96	24.38	.64	16.2
769LR_ 3/8 X 1/8	3/8	9.52	R-1/8	.19	4.82	5/8	15.9	.91	23.11	1.20	30.48	.82	20.83	.66	16.8
769LR_ 3/8 X 1/4	3/8	9.52	R-1/4	.28	7.11	5/8	15.9	.91	23.11	1.20	30.48	1.00	25.40	.66	16.8
769LR_ 3/8 X 3/8	3/8	9.52	R-3/8	.28	7.11	11/16	17.5	.94	23.87	1.23	31.24	1.03	26.16	.66	16.8
769LR_ 1/2 X 1/4	1/2	12.70	R-1/4	.28	7.11	13/16	20.6	1.02	25.90	1.42	36.07	1.11	28.19	.90	22.9
769LR_ 1/2 X 3/8	1/2	12.70	R-3/8	.38	9.50	13/16	20.6	1.02	25.90	1.42	36.07	1.11	28.19	.90	22.9
769LR_ 1/2 X 1/2	1/2	12.70	R-1/2	.41	10.41	13/16	20.6	1.02	25.90	1.42	36.07	1.30	33.02	.90	22.9
769LR_ 3/4 X 1/2	3/4	19.05	R-1/2	.47	11.94	1 1/16	27.0	1.17	29.71	1.57	39.88	1.45	36.83	.96	24.4
769LR_ 1 X 1	1	25.40	R-1	.86	21.84	1 3/8	34.9	1.45	36.83	1.93	49.02	1.83	46.48	1.23	31.2

Reference Specifications:
DIN - 2999
BS - 21
JIS - B0203
ISO - 7/1-BSP-T

Designation:
Marking LR on Flat

769 LN
MALE PIPE WELD
ELBOW

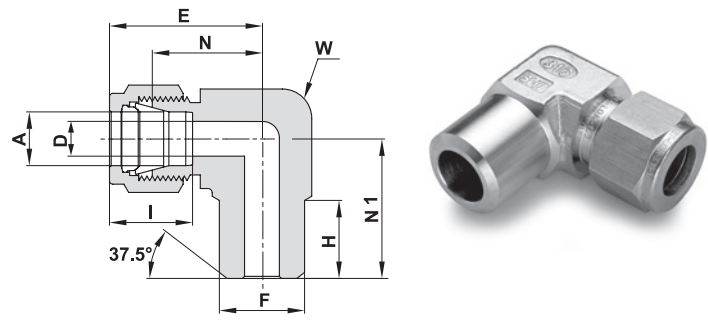

TUBE (INCH)

Ordering Information	A Tube O.D.		F Pipe Size		D		W Wrench Flat		N		H		E		N1		I	
	inch	mm	inch	mm	inch	mm	inch	mm	inch	mm	inch	mm	inch	mm	inch	mm	inch	mm
769LN_ 1/4 X 1/8	1/4	6.35	1/8	10.30	.19	4.82	1/2	12.7	.77	19.56	.38	9.65	1.06	26.92	.74	18.8	.60	15.2
769LN_ 1/4 X 1/4	1/4	6.35	1/4	13.70	.19	4.82	1/2	12.7	.77	19.56	.56	14.22	1.06	26.92	.92	23.37	.60	15.2
769LN_ 3/8 X 1/4	3/8	9.52	1/4	13.70	.28	7.11	5/8	15.9	.91	23.11	.56	14.22	1.20	30.48	1.00	25.40	.66	16.8
769LN_ 1/2 X 1/2	1/2	12.70	1/2	21.34	.41	10.41	13/16	20.6	1.02	25.90	.75	19.05	1.42	36.06	1.30	33.02	.90	22.9
769LN_ 3/4 X 3/4	3/4	19.05	3/4	26.67	.62	15.75	1 1/16	27.0	1.17	29.72	.75	19.05	1.57	39.88	1.45	36.83	.96	24.4

Designation:
Marking LN on Flat

"D" - Dimension is minimum opening. Dimensions are for reference only, and are subject to change without notice.

769 LW
TUBE SOCKET WELD
ELBOW

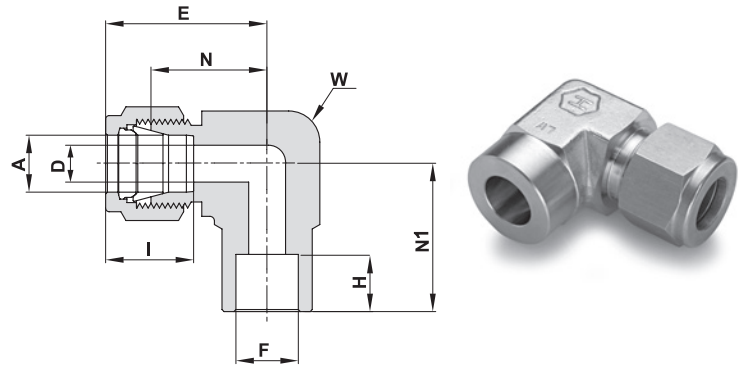

TUBE (INCH)

Ordering Information	A		F		D		W		N		H		E		N1		I	
	Tube O.D.		Tube O.D.				Wrench Flat											
	inch	mm	inch	mm	inch	mm	inch	mm	inch	mm	inch	mm	inch	mm	inch	mm	inch	mm
769LW _ 1/4 X 1/4	1/4	6.35	1/4	6.35	.19	4.82	1/2	12.7	.77	19.60	.31	7.87	1.06	26.98	.77	19.60	.60	15.2
769LW _ 3/8 X 3/8	3/8	9.52	3/8	9.52	.28	7.11	5/8	15.9	.91	23.11	.38	9.65	1.20	30.98	.91	23.11	.66	16.8
769LW _ 1/2 X 1/2	1/2	12.70	1/2	12.70	.41	10.41	15/16	23.8	1.02	25.90	.50	12.70	1.42	36.06	1.02	25.90	.90	22.9
769LW _ 3/4 X 3/4	3/4	19.05	3/4	19.05	.62	15.74	1 1/16	27.0	1.17	29.71	.56	14.22	1.57	39.87	1.17	29.71	.96	24.4
769LW _ 1 X 1	1	25.40	1	25.40	.88	22.35	1 3/8	34.9	1.45	36.83	.75	19.05	1.93	49.02	1.45	36.83	1.23	31.2

Designation:
 Marking LW on Flat

769 LT
REDUCING ELBOW

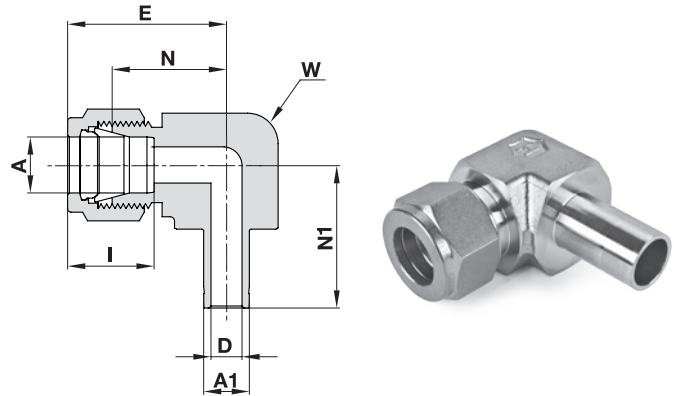

TUBE (METRIC) TO STUB (METRIC)

Ordering Information	A		A1		D		W		N		E		N1		I	
	Tube O.D.		Tube O.D.				Wrench Flat									
	mm	mm	mm	mm	mm	mm	inch	mm	mm	mm	mm	mm	mm	mm	mm	mm
769LT _ 6 X 6	6	6	6	6	4.0	4.0	1/2	12.7	19.6	19.6	27.0	23.8	23.8	15.3	15.3	15.3
769LT _ 12 X 12	12	12	12	12	8.8	8.8	1 1/8	28.6	27.9	27.9	38.0	40.4	40.4	22.8	22.8	22.8
769LT _ 15 X 15	15	15	15	15	12.0	12.0	1 1/8	28.6	27.9	27.9	38.0	41.0	41.0	24.4	24.4	24.4
769LT _ 22 X 22	22	22	22	22	18.3	18.3	1 3/8	34.9	34.5	34.5	44.6	50.0	50.0	26.0	26.0	26.0

TUBE (INCH) TO STUB (INCH)

Ordering Information	A		A1		D		W		N		E		N1		I	
	Tube O.D.		Tube O.D.				Wrench Flat									
	inch	mm	inch	mm	inch	mm	inch	mm	inch	mm	inch	mm	inch	mm	inch	mm
769LT _ 1/4 X 3/8	1/4	6.35	3/8	9.52	.19	4.82	5/8	15.9	.91	23.1	1.20	30.5	1.24	31.5	.60	15.2
769LT _ 1/4 X 1/2	1/4	6.35	1/2	12.7	.19	4.82	5/8	15.9	.91	23.1	1.20	30.5	1.28	32.5	.60	15.2

"D" - Dimension is minimum opening. Dimensions are for reference only, and are subject to change without notice.

770 L FEMALE ELBOW

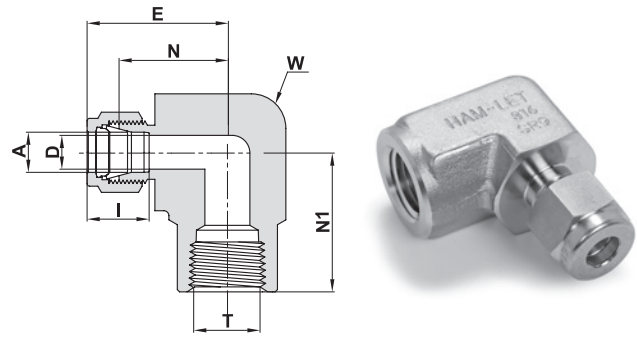

TUBE (METRIC) TO FEMALE NPT THREAD

Ordering Information	A Tube O.D.		T (NPT)	D		W Wrench Flat		N		E		N1		I
	mm	inch	inch	mm	inch	mm	inch	mm	inch	mm	inch	mm	inch	mm
770L_6 X 1/8	6		1/8	4.8	1/2	12.7		19.6		27.0		19.0		15.3
770L_6 X 1/4	6		1/4	4.8	11/16	17.5		22.4		29.8		22.4		15.3
770L_6 X 1/2	6		1/2	4.8	1 1/16	27.0		27.2		34.6		28.4		15.3
770L_8 X 1/4	8		1/4	6.4	11/16	17.5		23.1		30.6		22.4		16.2
770L_10 X 1/8	10		1/8	7.9	11/16	17.5		23.9		31.5		19.0		17.2
770L_10 X 1/4	10		1/4	7.9	13/16	20.6		25.9		33.5		22.4		17.2
770L_12 X 1/4	12		1/4	9.5	13/16	20.6		25.9		36.0		22.4		22.8
770L_12 X 1/2	12		1/2	9.5	1 1/16	27.0		28.7		38.8		28.4		22.8
770L_16 X 1/2	16		1/2	12.7	1 1/16	27.0		29.7		39.8		28.4		24.4

TUBE (INCH) TO FEMALE NPT THREAD

Ordering Information	A Tube O.D.		T (NPT)	D		W Wrench Flat		N		E		N1		I	
	inch	mm	inch	inch	mm	inch	mm	inch	mm	inch	mm	inch	mm	inch	
770L_1/8 X 1/8	1/8	3.17	1/8	.09	2.28	1/2	12.7	.71	18.03	.97	24.64	.75	19.05	.50	12.7
770L_1/8 X 1/4	1/8	3.17	1/4	.09	2.28	11/16	17.5	.82	20.80	1.08	27.43	.88	22.40	.50	12.7
770L_3/16 X 1/8	3/16	4.76	1/8	.12	3.04	1/2	12.7	.74	18.80	1.00	25.40	.75	19.05	.54	13.7
770L_1/4 X 1/8	1/4	6.35	1/8	.19	4.82	1/2	12.7	.77	19.55	1.06	26.92	.75	19.05	.60	15.2
770L_1/4 X 1/4	1/4	6.35	1/4	.19	4.82	11/16	17.5	.88	22.40	1.17	29.72	.88	22.40	.60	15.2
770L_1/4 X 3/8	1/4	6.35	3/8	.19	4.82	15/16	23.8	.96	24.38	1.25	31.75	.88	22.40	.60	15.2
770L_1/4 X 1/2	1/4	6.35	1/2	.19	4.82	1 1/16	27.0	1.07	27.18	1.36	34.54	1.12	28.45	.60	15.2
770L_5/16 X 1/8	5/16	7.93	1/8	.25	6.35	9/16	14.3	.84	21.30	1.13	28.70	.75	19.05	.64	16.2
770L_5/16 X 1/4	5/16	7.93	1/4	.25	6.35	11/16	17.5	.91	23.11	1.20	30.48	.88	22.40	.64	16.2
770L_3/8 X 1/8	3/8	9.52	1/8	.28	7.11	5/8	15.9	.91	23.11	1.20	30.48	.75	19.05	.66	16.8
770L_3/8 X 1/4	3/8	9.52	1/4	.28	7.11	11/16	17.5	0.94	23.87	1.23	31.24	.88	22.40	.66	16.8
770L_3/8 X 3/8	3/8	9.52	3/8	.28	7.11	15/16	23.8	1.02	25.90	1.31	33.27	.88	22.40	.66	16.8
770L_3/8 X 1/2	3/8	9.52	1/2	.28	7.11	1 1/16	27.0	1.13	28.70	1.42	36.07	1.12	28.45	.66	16.8
770L_1/2 X 1/4	1/2	12.70	1/4	.41	10.41	13/16	20.6	1.02	25.90	1.42	36.07	.88	22.40	.90	22.9
770L_1/2 X 3/8	1/2	12.70	3/8	.41	10.41	15/16	23.8	1.02	25.90	1.42	36.07	.88	22.40	.90	22.9
770L_1/2 X 1/2	1/2	12.70	1/2	.41	10.41	1 1/16	27.0	1.13	28.70	1.53	36.86	1.12	28.45	.90	22.9
770L_5/8 X 3/8	5/8	15.87	3/8	.50	12.70	15/16	23.8	1.10	27.90	1.50	38.10	.88	22.40	.96	24.4
770L_5/8 X 1/2	5/8	15.87	1/2	.50	12.70	1 1/16	27.0	1.17	29.70	1.57	39.86	1.12	28.45	.96	24.4
770L_3/4 X 1/2	3/4	19.05	1/2	.62	15.74	1 1/16	27.0	1.17	29.70	1.57	39.86	1.12	28.45	.96	24.4
770L_3/4 X 3/4	3/4	19.05	3/4	.62	15.74	1 3/8	34.9	1.36	34.54	1.76	44.70	1.25	31.75	.96	24.4
770L_7/8 X 3/4	7/8	22.22	3/4	.72	18.28	1 3/8	34.9	1.36	34.54	1.76	44.70	1.25	31.75	1.02	25.9
770L_1 X 3/4	1	25.40	3/4	.88	22.35	1 3/8	34.9	1.45	36.83	1.93	49.02	1.25	31.75	1.23	31.2
770L_1 X 1	1	25.40	1	.88	22.35	1 1/16	42.9	1.63	41.40	2.11	53.59	1.50	38.10	1.23	31.2

"D" - Dimension is minimum opening. Dimensions are for reference only, and are subject to change without notice.

771 L
MALE RUN TEE

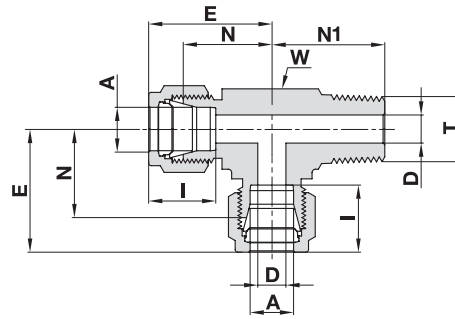

TUBE (METRIC) TO MALE NPT THREAD

Ordering Information	A Tube O.D.		T (NPT)	D		W Wrench Flat		N	E	N1	I
	mm	inch	inch	mm	inch	mm	mm	mm	mm	mm	mm
771L_6 X 1/8	6		1/8	4.8		1/2	12.7	19.6	27.0	18.8	15.3
771L_6 X 1/4	6		1/4	4.8		1/2	12.7	19.6	27.0	23.4	15.3
771L_8 X 1/8	8		1/8	4.8		5/8	15.9	22.4	29.9	20.8	16.2
771L_8 X 1/4	8		1/4	6.4		5/8	15.9	22.4	29.9	25.4	16.2
771L_10 X 1/4	10		1/4	7.1		13/16	20.6	25.9	33.5	28.2	17.2
771L_12 X 1/4	12		1/4	7.1		13/16	20.6	25.9	36.0	28.2	22.8
771L_12 X 3/8	12		3/8	9.5		13/16	20.6	25.9	36.0	28.2	22.8
771L_12 X 1/2	12		1/2	9.5		13/16	20.6	25.9	36.0	33.0	22.8
771L_16 X 1/2	16		1/2	11.9		15/16	23.8	27.9	38.0	35.0	24.4

TUBE (INCH) TO MALE NPT THREAD

Ordering Information	A Tube O.D.		T (NPT)	D		W Wrench Flat		N	E	N1	I				
	inch	mm	inch	inch	mm	inch	mm	inch	mm	inch	mm	inch	mm		
771L_1/8 X 1/8	1/8	3.17	1/8	.09	2.28	7/16	11.1	.67	17.02	.93	23.62	.70	17.78	.50	12.7
771L_1/8 X 1/4	1/8	3.17	1/4	.09	2.28	1/2	12.7	.71	18.03	.97	24.64	.92	23.40	.50	12.7
771L_3/16 X 1/8	3/16	4.76	1/8	.12	3.05	7/16	11.1	.70	17.78	.96	24.38	.70	17.78	.54	13.7
771L_1/4 X 1/8	1/4	6.35	1/8	.19	4.82	1/2	12.7	.77	19.56	1.06	26.92	.74	18.8	.60	15.2
771L_1/4 X 1/4	1/4	6.35	1/4	.19	4.82	1/2	12.7	.77	19.56	1.06	26.92	.92	23.37	.60	15.2
771L_5/16 X 1/8	5/16	7.93	1/8	.19	4.82	5/8	15.9	.88	22.35	1.17	29.71	.82	20.83	.64	16.2
771L_3/8 X 1/4	3/8	9.52	1/4	.28	7.11	5/8	15.9	.91	23.11	1.20	30.48	1.00	25.40	.66	16.8
771L_3/8 X 3/8	3/8	9.52	3/8	.28	7.11	13/16	20.6	1.02	25.91	1.31	33.27	1.11	28.19	.66	16.8
771L_1/2 X 3/8	1/2	12.70	3/8	.38	9.5	13/16	20.6	1.02	25.91	1.42	36.07	1.11	28.19	.90	22.9
771L_1/2 X 1/2	1/2	12.70	1/2	.41	10.41	13/16	20.6	1.02	25.91	1.42	36.07	1.30	33.00	.90	22.9
771L_5/8 X 1/2	5/8	15.87	1/2	.47	11.94	15/16	23.8	1.10	27.94	1.50	38.1	1.38	35.05	.96	24.4
771L_3/4 X 3/4	3/4	19.05	3/4	.62	15.75	1 1/8	28.6	1.17	29.72	1.57	39.88	1.45	36.83	.96	24.4

"D" - Dimension is minimum opening. Dimensions are for reference only, and are subject to change without notice.

**771LF
FEMALE RUN TEE**

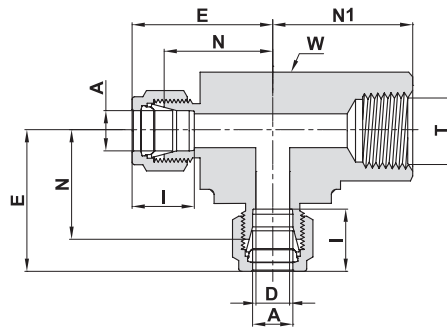

TUBE (METRIC) TO FEMALE NPT THREAD

Ordering Information	A	T (NPT)	D	W Wrench Flat		N	E	N1	I
	mm	inch	mm	inch	mm	mm	mm	mm	mm
771LF _ 6 X 1/8	6	1/8	4.8	5/8	15.9	19.6	27.0	19.0	15.3
771LF _ 6 X 1/4	6	1/4	4.8	13/16	20.6	22.4	29.8	22.4	15.3
771LF _ 8 X 1/8	8	1/8	6.4	5/8	15.9	22.4	29.9	22.4	16.2
771LF _ 8 X 1/4	8	1/4	6.4	13/16	20.6	23.1	30.6	26.0	16.2
771LF _ 10 X 1/4	10	1/4	7.9	13/16	20.6	25.9	33.5	22.4	17.2
771LF _ 12 X 1/4	12	1/4	9.5	13/16	20.6	25.9	36.0	22.4	22.8
771LF _ 12 X 3/8	12	3/8	9.5	15/16	23.8	25.9	36.0	28.2	22.8
771LF _ 12 X 1/2	12	1/2	9.5	1 1/8	28.6	29.7	39.8	28.4	22.8
771LF _ 16 X 1/2	16	1/2	12.7	1 1/8	28.6	29.7	39.8	28.4	24.4

TUBE (INCH) TO FEMALE NPT THREAD

Ordering Information	A Tube O.D.		T (NPT)	D		W Wrench Flat		N		E		N1		I	
	inch	mm	inch	inch	mm	inch	mm	inch	mm	inch	mm	inch	mm	inch	mm
771LF _ 1/8 X 1/8	1/8	3.17	1/8	.09	2.28	5/8	15.9	.71	18.00	.97	24.63	.75	19.05	.50	12.7
771LF _ 1/4 X 1/8	1/4	6.35	1/8	.19	4.82	5/8	15.9	.77	19.55	1.06	26.92	.75	19.05	.60	15.2
771LF _ 1/4 X 1/4	1/4	6.35	1/4	.19	4.82	13/16	20.6	.88	22.35	1.17	29.71	.88	22.35	.60	15.2
771LF _ 3/8 X 1/4	3/8	9.52	1/4	.28	7.11	13/16	20.6	.94	23.87	1.23	31.24	.88	22.35	.66	16.8
771LF _ 1/2 X 3/8	1/2	12.70	3/8	.41	10.41	15/16	23.8	1.02	25.9	1.42	36.07	.88	22.35	.90	22.9
771LF _ 1/2 X 1/2	1/2	12.70	1/2	.41	10.41	1 1/8	28.6	1.17	29.72	1.57	39.88	1.12	28.45	.90	22.9
771LF _ 3/4 X 3/4	3/4	19.05	3/4	.62	15.75	1 3/8	34.9	1.36	34.54	1.76	44.70	1.25	31.75	.96	24.4
771LF _ 1 X 3/4	1	25.4	3/4	.88	22.35	1 3/8	34.9	1.45	36.83	1.93	49.02	1.25	31.75	1.23	31.2
771LF _ 1 X 1	1	25.4	1	.88	22.35	1 11/16	42.9	1.63	41.40	2.11	53.59	1.50	38.10	1.23	31.2

"D" - Dimension is minimum opening. Dimensions are for reference only, and are subject to change without notice.

772 L
MALE BRANCH TEE

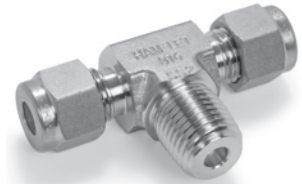
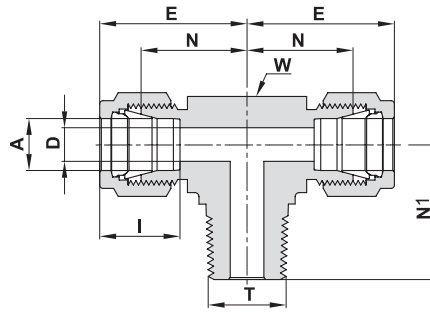

TUBE (METRIC) TO MALE NPT THREAD

Ordering Information	A Tube O.D.		T (NPT)	D		W Wrench Flat		N		E		N1		I	
	mm	mm	inch	mm	mm	inch	mm	mm	mm	mm	mm	mm	mm	mm	mm
772L_6 X 1/8	6	6	1/8	4.8	4.8	1/2	12.7	12.7	19.6	19.6	27.0	18.8	18.8	15.3	15.3
772L_6 X 1/4	6	6	1/4	4.8	4.8	1/2	12.7	12.7	19.6	19.6	27.0	23.4	23.4	15.3	15.3
772L_8 X 1/8	8	8	1/8	4.8	4.8	5/8	15.9	15.9	22.4	22.4	29.9	20.8	20.8	16.2	16.2
772L_8 X 1/4	8	8	1/4	6.4	6.4	5/8	15.9	15.9	22.4	22.4	29.9	25.4	25.4	16.2	16.2
772L_10 X 1/4	10	10	1/4	7.1	7.1	13/16	20.6	20.6	25.9	25.9	33.5	28.2	28.2	17.2	17.2
772L_12 X 1/4	12	12	1/4	7.1	7.1	13/16	20.6	20.6	25.9	25.9	36.0	28.2	28.2	22.8	22.8
772L_12 X 3/8	12	12	3/8	9.5	9.5	13/16	20.6	20.6	25.9	25.9	36.0	28.2	28.2	22.8	22.8
772L_12 X 1/2	12	12	1/2	9.5	9.5	13/16	20.6	20.6	25.9	25.9	36.0	33.0	33.0	22.8	22.8
772L_16 X 1/2	16	16	1/2	11.9	11.9	15/16	23.8	23.8	28.7	28.7	38.8	35.8	35.8	24.4	24.4

TUBE (INCH) TO MALE NPT THREAD

Ordering Information	A Tube O.D.		T (NPT)	D		W Wrench Flat		N		E		N1		I	
	inch	mm	inch	inch	mm	inch	mm	inch	mm	inch	mm	inch	mm	inch	mm
772L_1/8 X 1/8	1/8	3.17	1/8	.09	2.28	7/16	11.1	.67	17.02	.93	23.62	.70	17.78	.50	12.7
772L_1/8 X 1/4	1/8	3.17	1/4	.09	2.28	1/2	12.7	.71	18.03	.97	24.64	.92	23.37	.50	12.7
772L_3/16 X 1/8	3/16	4.76	1/8	.12	3.04	7/16	11.1	.70	17.78	.96	24.38	.70	17.78	.54	13.7
772L_1/4 X 1/8	1/4	6.35	1/8	.19	4.82	1/2	12.7	.77	19.56	1.06	26.92	.74	18.80	.60	15.2
772L_1/4 X 1/4	1/4	6.35	1/4	.19	4.82	1/2	12.7	.77	19.56	1.06	26.92	.92	23.37	.60	15.2
772L_5/16 X 1/8	5/16	7.93	1/8	.19	4.82	5/8	15.9	.88	22.35	1.17	29.71	.82	20.83	.64	16.2
772L_3/8 X 1/4	3/8	9.52	1/4	.28	7.11	5/8	15.9	.91	23.11	1.20	30.48	1.00	25.40	.66	16.8
772L_3/8 X 3/8	3/8	9.52	3/8	.28	7.11	13/16	20.6	1.02	25.91	1.31	33.27	1.11	28.19	.66	16.8
772L_1/2 X 3/8	1/2	12.70	3/8	.38	9.65	13/16	20.6	1.02	25.91	1.42	36.07	1.11	28.19	.90	22.9
772L_1/2 X 1/2	1/2	12.70	1/2	.41	10.41	13/16	20.6	1.02	25.91	1.42	36.07	1.30	33.02	.90	22.9
772L_5/8 X 1/2	5/8	15.87	1/2	.47	11.94	15/16	23.8	1.13	28.7	1.53	38.86	1.41	35.81	.96	24.4
772L_3/4 X 3/4	3/4	19.05	3/4	.62	15.75	1 1/8	28.6	1.17	29.72	1.57	39.88	1.45	36.83	.96	24.4

"D" - Dimension is minimum opening. Dimensions are for reference only, and are subject to change without notice.

772 LF
FEMALE BRANCH TEE

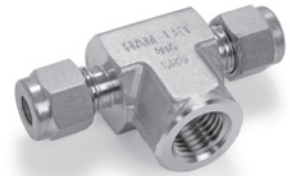
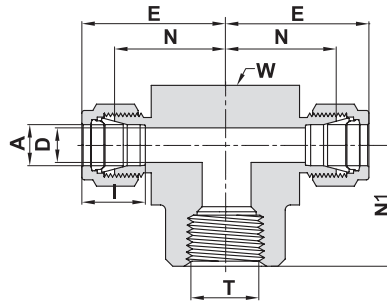

TUBE (METRIC) TO FEMALE NPT THREAD

Ordering Information	A Tube O.D.		T (NPT)	D		W Wrench Flat		N		E		N1		I	
	mm	inch	inch	mm	inch	mm	inch	mm	inch	mm	inch	mm	inch	mm	inch
772LF_ 6 X 1/8	6		1/8	4.8		5/8	15.9	19.6		27.0		19.0		15.3	
772LF_ 6 X 1/4	6		1/4	4.8		13/16	20.6	22.4		29.8		22.4		15.3	
772LF_ 8 X 1/8	8		1/8	6.4		5/8	15.9	22.4		29.9		19.0		16.2	
772LF_ 8 X 1/4	8		1/4	6.4		13/16	20.6	23.1		30.6		22.4		16.2	
772LF_ 10 X 1/4	10		1/4	7.9		13/16	20.6	25.9		33.5		22.4		17.2	
772LF_ 10 X 3/8	10		3/8	7.9		15/16	23.8	25.9		33.5		22.4		17.2	
772LF_ 12 X 1/4	12		1/4	9.5		13/16	20.6	25.9		36.0		22.4		22.8	
772LF_ 12 X 3/8	12		3/8	9.5		15/16	23.8	25.9		36.0		22.4		22.8	
772LF_ 12 X 1/2	12		1/2	9.5		1 1/8	28.6	28.7		38.8		28.4		22.8	
772LF_ 16 X 1/2	16		1/2	12.7		1 1/8	28.6	28.7		38.8		28.4		24.4	

TUBE (INCH) TO FEMALE NPT THREAD

Ordering Information	A Tube O.D.		T (NPT)	D		W Wrench Flat		N		E		N1		I	
	inch	mm	inch	inch	mm	inch	mm	inch	mm	inch	mm	inch	mm	inch	mm
772LF_ 1/8 X 1/8	1/8	3.17	1/8	.09	2.28	5/8	15.9	.70	18.00	.97	24.64	.75	19.05	.50	12.7
772LF_ 1/4 X 1/8	1/4	6.35	1/8	.19	4.82	5/8	15.9	.77	19.56	1.06	26.96	.75	19.05	.60	15.2
772LF_ 1/4 X 1/4	1/4	6.35	1/4	.19	4.82	13/16	20.6	.88	22.35	1.17	29.71	.88	22.35	.60	15.2
772LF_ 3/8 X 1/4	3/8	9.52	1/4	.28	7.11	13/16	20.6	.94	23.88	1.23	31.24	.88	22.35	.66	16.8
772LF_ 3/8 X 3/8	3/8	9.52	3/8	.28	7.11	15/16	23.8	1.02	25.90	1.31	33.27	.88	22.35	.66	16.8
772LF_ 3/8 X 1/2	3/8	9.52	1/2	.28	7.11	1 1/8	28.6	1.13	28.70	1.42	36.07	1.12	28.45	.66	16.8
772LF_ 1/2 X 1/4	1/2	12.70	1/4	.41	10.41	13/16	20.6	1.02	25.90	1.42	36.07	.88	22.35	.90	22.9
772LF_ 1/2 X 3/8	1/2	12.70	3/8	.41	10.41	15/16	23.8	1.02	25.90	1.42	36.07	.88	22.35	.90	22.9
772LF_ 1/2 X 1/2	1/2	12.70	1/2	.41	10.41	1 1/8	28.6	1.13	28.70	1.53	38.86	1.12	28.45	.90	22.9
772LF_ 5/8 X 1/2	5/8	15.87	1/2	.50	12.70	1 1/8	28.6	1.13	28.70	1.53	38.86	1.12	28.44	.96	24.4
772LF_ 3/4 X 3/4	3/4	19.05	3/4	.62	15.74	1 3/8	34.9	1.36	34.50	1.76	44.70	1.25	31.75	.96	24.4
772LF_ 1 X 3/4	1	25.4	3/4	.88	22.35	1 3/8	34.9	1.45	36.83	1.93	49.02	1.25	31.75	1.23	31.2
772LF_ 1 X 1	1	25.4	1	.88	22.35	1 11/16	42.9	1.63	41.40	2.11	53.60	1.50	38.10	1.23	31.2

"D" - Dimension is minimum opening. Dimensions are for reference only, and are subject to change without notice.

774 L BULKHEAD UNION

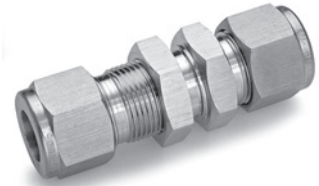
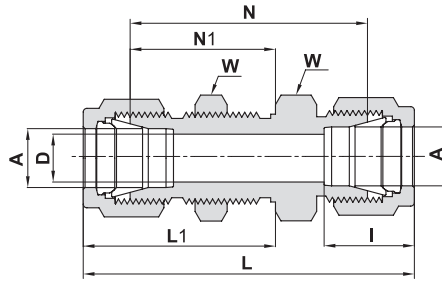

TUBE (METRIC) TO TUBE (METRIC)

Ordering Information	A Tube O.D.		D		W Hex. Flat		N		N1		L		L1		I		Panel hole drill size		Max. Panel thickness	
	mm	mm	mm	mm	mm	mm	mm	mm	mm	mm	mm	mm	mm	mm	mm	mm	mm	mm	mm	mm
774L_3	3		2.4		14		38.1		24.6		51.3		31.2		12.9		8.30		12.7	
774L_4	4		2.4		14		40.4		25.4		53.6		32.0		13.7		9.90		12.7	
774L_6	6		4.8		16		42.9		26.2		57.7		33.6		15.3		11.50		10.2	
774L_8	8		6.4		18		46.0		28.6		61.0		36.1		16.2		13.10		11.2	
774L_10	10		7.9		22		48.5		29.4		63.7		37.0		17.2		16.25		11.2	
774L_12	12		9.5		24		50.8		31.8		71.0		41.9		22.8		19.50		12.7	
774L_14	14		11.0		27		52.3		32.5		72.5		42.6		24.4		22.80		12.7	
774L_15	15		11.9		27		52.3		32.5		72.5		42.6		24.4		22.80		12.7	
774L_16	16		12.7		27		52.3		32.5		72.5		42.6		24.4		22.80		12.7	
774L_18	18		15.1		30		58.7		37.3		78.9		47.4		24.4		26.00		16.8	
774L_20	20		15.9		35		64.3		42.9		84.5		53.0		26.0		29.00		19.0	
774L_25	25		21.8		41		71.4		45.2		96.0		57.5		31.3		33.70		19.0	
774L_38	*38		33.7		60		89.8		51.9		145.0		79.5		49.4		50.50		19.0	

TUBE (INCH) TO TUBE (INCH)

Ordering Information	A Tube O.D.		D		W Hex. Flat		N		N1		L		L1		I		Panel hole drill size		Max. Panel thickness	
	inch	mm	inch	mm	inch	mm	inch	mm	inch	mm	inch	mm	inch	mm	inch	mm	inch	mm	inch	mm
774L_1/16	1/16	1.58	.05	1.27	5/16		.94	23.88	.53	13.46	1.24	31.5	.68	17.3	.34	8.6	13/64	5.16	.12	3.05
774L_1/8	1/8	3.17	.09	2.28	1/2		1.50	38.10	.97	24.63	2.02	51.30	1.23	31.24	.50	12.7	21/64	8.33	.50	12.70
774L_3/16	3/16	4.76	.12	3.04	9/16		1.59	40.38	1.00	25.40	2.11	53.59	1.26	32.00	.54	13.7	25/64	9.92	.50	12.70
774L_1/4	1/4	6.35	.19	4.82	5/8		1.69	42.92	1.03	26.16	2.27	57.65	1.32	33.52	.60	15.2	29/64	11.50	.40	10.16
774L_5/16	5/16	7.93	.25	6.35	11/16		1.81	45.97	1.12	28.44	2.39	60.70	1.41	35.81	.64	16.2	33/64	13.09	.44	11.17
774L_3/8	3/8	9.52	.28	7.11	3/4		1.87	47.5	1.16	29.46	2.45	62.2	1.45	36.83	.66	16.8	37/64	14.68	.44	11.17
774L_1/2	1/2	12.70	.41	10.41	15/16		2.00	50.80	1.25	31.75	2.80	71.12	1.65	41.91	.90	22.9	49/64	19.44	.50	12.70
774L_5/8	5/8	15.87	.50	12.70	1 1/16		2.06	52.32	1.28	32.51	2.86	72.64	1.68	42.67	.96	24.4	57/64	22.62	.50	12.70
774L_3/4	3/4	19.05	.62	15.75	1 3/16		2.31	58.67	1.47	37.33	3.11	78.99	1.87	47.49	.96	24.4	1 1/64	25.79	.66	16.76
774L_1	1	25.40	.88	22.35	1 5/8		2.81	71.37	1.78	45.21	3.77	95.76	2.26	57.40	1.23	31.2	1 21/64	33.73	.75	19.05
774L_1 1/4	*1 1/4	31.75	1.09	27.70	1 7/8		3.11	79.00	1.88	47.75	4.85	123.19	2.75	69.85	1.62	41.2	1 41/64	41.67	.75	19.05
774L_1 1/2	*1 1/2	38.10	1.34	34.00	2 1/4		3.34	84.80	1.94	49.28	5.48	139.19	3.01	76.45	1.97	50.0	1 61/64	49.61	.75	19.05
774L_2	*2	50.80	1.81	45.97	2 3/4		4.16	105.66	2.22	56.39	7.10	180.34	3.69	93.73	2.66	67.6	2 41/64	67.07	.75	19.05

* Including low friction paste, See page 89

"D" - Dimension is minimum opening. Dimensions are for reference only, and are subject to change without notice.

774 LF
BULKHEAD FEMALE
CONNECTOR

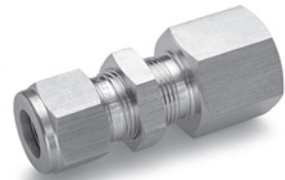
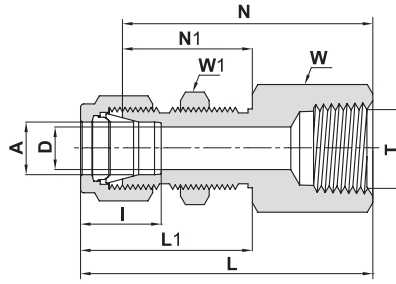

TUBE (METRIC) TO FEMALE NPT THREAD

Ordering Information	A Tube O.D.		T (NPT)		D		W Hex. Flat		W1 Hex. Flat		N		N1		L		L1		I		Panel hole drill size		Max. Panel thickness	
	mm	inch	mm	inch	mm	mm	mm	mm	mm	mm	mm	mm	mm	mm	mm	mm	mm	mm	mm	mm	mm	mm	mm	
774LF_6 X 1/4	6	1/4	4.8	19	16	44.4	26.2	51.8	33.6	15.3	11.5	10.2												
774LF_12 X 1/2	1 2	1/2	9.5	27	24	56.4	31.8	66.5	41.9	22.8	19.5	12.7												

TUBE (INCH) TO FEMALE NPT THREAD

Ordering Information	A Tube O.D.		T (NPT)		D		W Hex. Flat		W1 Hex. Flat		N		N1		L		L1		I		Panel hole drill size		Max. Panel thickness	
	inch	mm	inch	mm	inch	mm	inch	mm	inch	mm	inch	mm	inch	mm	inch	mm	inch	mm	inch	mm	inch	mm		
774LF_1/8X1/8	1/8	3.17	1/8	.09	2.28	9/16	1/2	1.50	38.10	.97	24.63	1.76	44.70	1.23	31.24	.50	12.7	21/64	8.33	.50	12.70			
774LF_1/4X1/8	1/4	6.35	1/8	.19	4.82	5/8	5/8	1.56	39.62	1.03	26.16	1.85	46.99	1.32	33.52	.60	15.2	29/64	11.50	.40	10.16			
774LF_1/4X1/4	1/4	6.35	1/4	.19	4.82	3/4	5/8	1.75	44.45	1.03	26.16	2.04	51.81	1.32	33.52	.60	15.2	29/64	11.50	.40	10.16			
774LF_3/8X1/4	3/8	9.52	1/4	.28	7.11	3/4	3/4	1.88	47.75	1.16	29.46	2.17	55.11	1.45	36.83	.66	16.8	37/64	14.68	.44	11.17			
774LF_1/2X3/8	1/2	12.70	3/8	.41	10.41	15/16	15/16	2.03	51.56	1.25	31.75	2.43	61.72	1.65	41.91	.90	22.9	49/64	19.44	.50	12.70			
774LF_1/2X1/2	1/2	12.70	1/2	.41	10.41	1 1/16	15/16	2.22	56.38	1.25	31.75	2.62	66.54	1.65	41.91	.90	22.9	49/64	19.44	.50	12.70			

774 LT
BULKHEAD REDUCER

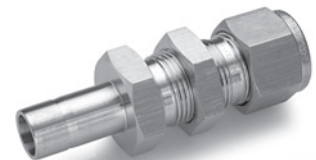
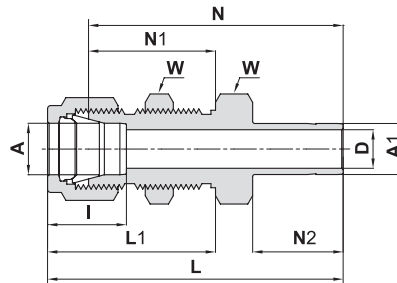

TUBE (INCH) TO TUBE (INCH)

Ordering Information	A Tube O.D.		A1 Tube O.D.		D		W Hex. Flat		N		N1		N2		L		L1		I		Panel hole drill size		Max. Panel thickness	
	inch	mm	inch	mm	inch	mm	inch	mm	inch	mm	inch	mm	inch	mm	inch	mm	inch	mm	inch	mm	inch	mm		
774LT_1/8X1/8	1/8	3.17	1/8	.08	2.03	1/2	1.69	42.92	.97	24.63	.53	13.46	1.95	49.53	1.23	31.24	.50	12.7	21/64	8.33	.50	12.70		
774LT_1/4X1/4	1/4	6.35	1/4	.17	4.20	5/8	1.91	48.50	1.03	26.16	.62	15.74	2.20	55.88	1.32	33.52	.60	15.2	29/64	11.50	.40	10.16		
774LT_3/8X3/8	3/8	9.52	3/8	.28	7.11	3/4	2.12	53.85	1.16	29.46	.69	17.52	2.41	61.21	1.45	36.83	.66	16.8	37/64	14.68	.44	11.17		
774LT_1/2X1/2	1/2	12.7	1/2	.39	9.90	15/16	2.47	62.73	1.25	31.75	.91	23.11	2.87	72.89	1.65	41.91	.90	22.9	49/64	19.44	.50	12.70		
774LT_5/8X5/8	5/8	15.87	5/8	.50	12.70	1 1/16	2.56	65.02	1.28	32.51	.97	24.64	2.96	75.18	1.68	42.67	.96	24.4	57/64	22.62	.50	12.70		
774LT_3/4X3/4	3/4	19.05	3/4	.58	14.73	1 3/4	2.81	71.37	1.47	37.33	.97	24.64	3.21	81.53	1.87	47.49	.96	24.4	1 1/64	25.79	.66	16.76		
774LT_1X1	1	25.40	1	.80	20.30	1 5/8	3.47	88.14	1.78	45.21	1.30	33.02	3.95	100.33	2.26	57.40	1.23	31.2	1 21/64	33.73	.75	19.05		

"D" - Dimension is minimum opening. Dimensions are for reference only, and are subject to change without notice.

**774 LM
BULKHEAD MALE
CONNECTOR**

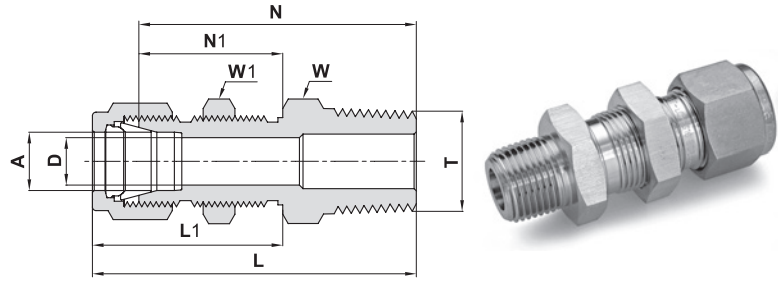

TUBE (METRIC) TO MALE NPT THREAD

Ordering Information	A Tube O.D.		T (NPT)	D		W Hex. Flat	W1 Hex. Flat	N	N1	L	L1	Panel hole drill size		Max. Panel thickness	
	mm	inch	inch	mm	mm	mm	mm	mm	mm	mm	mm	mm	mm	mm	
774LM_6 X 1/8	6	1/8	1/8	4.8	4.8	16	16	42.2	26.2	49.6	33.6	11.5	11.5	10.2	
774LM_6 X 1/4	6	1/4	1/4	4.8	4.8	16	16	46.2	26.2	53.6	33.6	11.5	11.5	10.2	
774LM_12 X 1/2	12	1/2	1/2	9.5	9.5	24	24	58.7	31.8	68.8	41.9	19.5	19.5	12.7	

TUBE (INCH) TO MALE NPT THREAD

Ordering Information	A Tube O.D.		T (NPT)	D		W Hex. Flat	W1 Hex. Flat	N	N1	L	L1	Panel hole drill size		Max. Panel thickness					
	inch	mm	inch	inch	mm	inch	inch	inch	mm	inch	mm	inch	mm	inch	mm				
774LM_1/8 X 1/8	1/8	3.17	1/8	.09	2.28	1/2	1/2	1.57	39.90	.97	24.60	1.83	46.48	1.23	31.24	21/64	8.33	.50	12.70
774LM_1/4 X 1/8	1/4	6.35	1/8	.19	4.82	5/8	5/8	1.66	42.20	1.03	26.20	1.95	49.53	1.32	33.52	29/64	11.50	.40	10.16
774LM_1/4 X 1/4	1/4	6.35	1/4	.19	4.82	5/8	5/8	1.84	46.70	1.03	26.16	2.13	54.10	1.32	33.52	29/64	11.50	.40	10.16
774LM_3/8 X 1/4	3/8	9.52	1/4	.28	7.11	3/4	3/4	1.97	50.00	1.16	29.46	2.26	57.40	1.45	36.83	37/64	14.68	.44	11.17
774LM_3/8 X 3/8	3/8	9.52	3/8	.28	7.11	3/4	3/4	1.97	50.04	1.16	29.46	2.26	57.40	1.45	36.83	37/64	14.68	.44	11.17
774LM_3/8 X 1/2	3/8	9.52	1/2	.28	7.11	7/8	3/4	2.22	56.39	1.16	29.46	2.51	63.75	1.45	36.83	37/64	14.68	.44	11.17
774LM_1/2 X 3/8	1/2	12.70	3/8	.40	10.40	15/16	15/16	2.09	53.10	1.25	31.75	2.49	63.25	1.65	41.91	49/64	19.44	.50	12.70
774LM_1/2 X 1/2	1/2	12.70	1/2	.40	10.40	15/16	15/16	2.31	58.70	1.25	31.70	2.71	68.83	1.65	41.91	49/64	19.44	.50	12.70
774LM_3/4 X 3/4	3/4	19.05	3/4	.62	15.74	1 3/16	1 3/16	2.60	66.04	1.47	37.33	3.00	76.20	1.87	47.49	1 1/64	25.79	.66	16.76
774LM_1 X 1	1	25.4	1	.88	22.35	1 5/8	1 5/8	3.67	93.21	1.78	45.21	3.19	81.02	2.26	57.40	1 21/64	33.73	.75	19.05

"D" - Dimension is minimum opening. Dimensions are for reference only, and are subject to change without notice.

**775 L
BULKHEAD REDUCING
UNION**

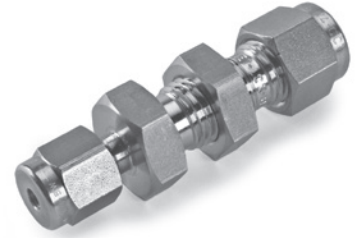
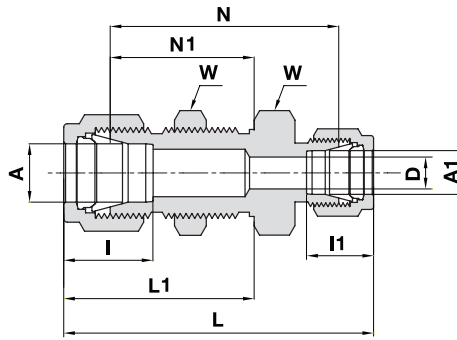

TUBE (METRIC) TO TUBE (INCH)

Ordering Information	A		A1		D		W		N		N1		L		L1		I		I1		Panel hole drill size		Max. Panel thickness	
	Tube O.D.		Tube O.D.		mm		Hex. Flat		mm		mm		mm		mm		mm		mm		mm		mm	
775L_6 X 1/8	6	1/8	2.4	16	43.9	26.2	55.1	33.6	15.3	12.7	11.5	10.2												
775L_6 X 1/4	6	1/4	4.8	16	42.9	26.2	57.7	33.6	15.3	15.2	11.5	10.2												
775L_12 X 1/2	12	1/2	9.5	24	50.8	31.8	71.1	41.9	22.8	22.9	19.5	12.7												
775L_18 X 3/4	18	3/4	15.1	30	58.7	37.3	79.0	47.4	24.4	24.4	26.0	16.8												

TUBE (INCH) TO TUBE (INCH)

Ordering Information	A		A1		D		W		N		N1		L		L1		I		I1		Panel hole drill size		Max. Panel thickness	
	Tube O.D.		Tube O.D.		inch		Hex. Flat		inch		inch		inch		inch		inch		inch		inch		inch	
775L_1/8 X 1/16	1/8	3.17	1/16	1.58	.05	1.27	1/2	1.44	36.57	.97	24.64	1.85	46.99	1.23	31.24	.50	12.7	.34	8.6	21/64	8.33	.50	12.70	
775L_3/16 X 1/4	3/16	4.76	1/4	6.35	.12	3.04	9/16	1.62	41.15	1.00	25.40	2.17	55.12	1.26	32.00	.54	13.7	.60	15.2	25/64	9.92	.50	12.70	
775L_1/4 X 1/8	1/4	6.35	1/8	3.17	.09	2.28	5/8	1.62	41.15	1.03	26.16	2.17	55.12	1.32	33.53	.60	15.2	.50	12.7	29/64	11.50	.40	10.16	
775L_1/4 X 3/8	1/4	6.35	3/8	9.52	.19	4.82	5/8	1.74	44.20	1.03	26.16	2.61	66.29	1.32	33.53	.60	15.2	.66	16.8	29/64	11.50	.40	10.16	
775L_3/8 X 1/4	3/8	9.52	1/4	6.35	.19	4.82	3/4	1.81	45.97	1.16	29.46	2.39	60.71	1.45	36.83	.66	16.8	.60	15.2	37/64	14.68	.44	11.17	
775L_1/2 X 1/4	1/2	12.70	1/4	6.35	.19	4.82	15/16	1.94	49.28	1.25	31.75	2.63	66.80	1.65	41.91	.90	22.9	.60	15.2	49/64	19.44	.50	12.70	
775L_1/2 X 5/8	1/2	12.70	5/8	15.87	.41	10.41	15/16	2.03	51.56	1.25	31.75	2.83	71.88	1.65	41.91	.90	22.9	.60	15.2	49/64	19.44	.50	12.70	
775L_5/8 X 3/8	5/8	15.87	3/8	9.52	.28	7.11	1 1/16	2.06	52.32	1.28	32.51	2.75	69.85	1.68	42.67	.96	24.4	.66	16.8	57/64	22.62	.50	12.70	

"D" - Dimension is minimum opening. Dimensions are for reference only, and are subject to change without notice.

7102 L UNION CROSS

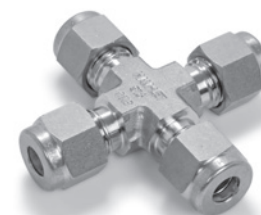
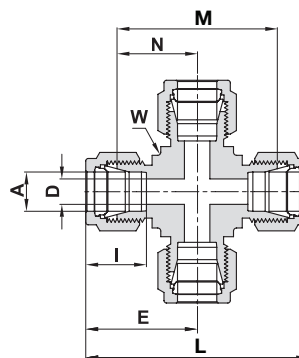

ALL TUBES (METRIC)

Ordering Information	A Tube O.D.		D		W Wrench Flat		N		E		M		L		I	
	mm	mm	mm	mm	inch	mm	mm	mm	mm	mm	mm	mm	mm	mm	mm	mm
7102L_3	3	3	2.4	2.4	3/8	9.5	15.7	15.7	22.3	22.3	31.5	31.5	44.7	44.7	12.9	12.9
7102L_6	6	6	4.8	4.8	1/2	12.7	19.6	19.6	27.0	27.0	39.1	39.1	53.9	53.9	15.3	15.3
7102L_8	8	8	6.4	6.4	5/8	15.9	22.4	22.4	29.9	29.9	44.7	44.7	59.7	59.7	16.2	16.2
7102L_10	10	10	7.9	7.9	13/16	20.6	25.9	25.9	33.5	33.5	51.8	51.8	67.0	67.0	17.2	17.2
7102L_12	12	12	9.5	9.5	13/16	20.6	25.9	25.9	36.0	36.0	51.8	51.8	72.0	72.0	22.8	22.8
7102L_16	16	16	12.7	12.7	15/16	23.8	26.9	26.9	37.0	37.0	53.8	53.8	74.0	74.0	24.4	24.4
7102L_18	18	18	15.1	15.1	1 1/16	27.0	28.2	28.2	38.3	38.3	56.4	56.4	76.6	76.6	24.4	24.4
7102L_20	20	20	15.9	15.9	1 3/8	34.9	34.5	34.5	44.6	44.6	69.0	69.0	89.3	89.3	26.0	26.0
7102L_22	22	22	18.3	18.3	1 3/8	34.9	34.6	34.6	44.7	44.7	69.1	69.1	89.4	89.4	26.0	26.0
7102L_25	25	25	21.8	21.8	1 3/8	34.9	36.8	36.8	49.1	49.1	73.7	73.7	98.3	98.3	31.3	31.3

ALL TUBES (INCH)

Ordering Information	A Tube O.D.		D		W Wrench Flat		N		E		M		L		I	
	inch	mm	inch	mm	inch	mm	inch	mm	inch	mm	inch	mm	inch	mm	inch	mm
7102L_1/8	1/8	3.17	.09	2.28	3/8	9.5	.62	15.74	.88	22.35	1.24	31.48	1.76	44.70	.50	12.7
7102L_1/4	1/4	6.35	.19	4.82	1/2	12.7	.77	19.56	1.06	26.92	1.54	39.12	2.12	53.84	.60	15.2
7102L_5/16	5/16	7.93	.25	6.35	5/8	15.9	.88	22.35	1.17	29.71	1.76	44.70	2.34	59.42	.64	16.2
7102L_3/8	3/8	9.52	.28	7.11	5/8	15.9	.91	23.11	1.20	30.48	1.82	46.22	2.40	60.96	.66	16.8
7102L_1/2	1/2	12.70	.41	10.41	13/16	20.6	1.02	25.9	1.42	36.07	2.04	51.80	2.84	72.14	.90	22.9
7102L_3/4	3/4	19.05	.62	15.74	1 1/16	27.0	1.17	29.72	1.57	39.88	2.34	59.44	3.14	79.76	.96	24.4
7102L_1	1	25.40	.88	22.35	1 3/8	34.9	1.45	36.8	1.93	49.02	2.90	73.60	3.86	98.04	1.23	31.2

"D" - Dimension is minimum opening. Dimensions are for reference only, and are subject to change without notice.

**7108 L
CAP**

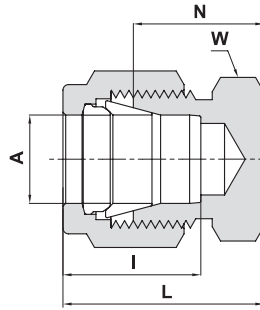

CAPPING END OF TUBE (METRIC)

Ordering Information	A Tube O.D.		W Hex. Flat	N		L		I	
	inch	mm	mm	inch	mm	inch	mm	inch	mm
7108L_2		2	12		13.5		20.1		12.9
7108L_3		3	12		13.5		20.1		12.9
7108L_4		4	12		14.7		21.3		13.7
7108L_6		6	14		15.7		23.1		15.3
7108L_8		8	15		17.0		24.5		16.2
7108L_10		10	18		19.0		26.6		17.2
7108L_12		12	22		19.0		29.1		22.8
7108L_14		14	24		19.8		29.9		24.4
7108L_15		15	24		19.8		29.9		24.4
7108L_16		16	24		19.8		29.9		24.4
7108L_18		18	27		21.3		31.4		24.4
7108L_20		20	30		23.9		34.0		26.0
7108L_22		22	30		23.9		34.0		26.0
7108L_25		25	35		26.2		38.5		31.3
7108L_38		*38	55		37.8		65.4		49.4

CAPPING END OF TUBE (INCH)

Ordering Information	A Tube O.D.		W Hex. Flat	N		L		I	
	inch	mm	inch	inch	mm	inch	mm	inch	mm
7108L_1/16	1/16	1.58	5/16	.44	11.17	.59	14.98	.34	8.6
7108L_1/8	1/8	3.17	7/16	.53	13.46	.79	20.06	.50	12.7
7108L_3/16	3/16	4.76	7/16	.58	14.73	.84	21.84	.54	13.7
7108L_1/4	1/4	6.35	1/2	.63	16.00	.92	23.37	.60	15.2
7108L_5/16	5/16	7.93	9/16	.67	17.01	.96	24.38	.64	16.2
7108L_3/8	3/8	9.52	5/8	.72	18.28	1.01	26.65	.66	16.8
7108L_1/2	1/2	12.70	13/16	.75	19.05	1.15	29.21	.90	22.9
7108L_5/8	5/8	15.87	15/16	.78	19.81	1.18	29.97	.96	24.4
7108L_3/4	3/4	19.05	1 1/16	.84	21.33	1.24	31.49	.96	24.4
7108L_7/8	7/8	22.22	1 3/16	.94	23.88	1.34	34.04	1.02	25.9
7108L_1	1	25.40	1 3/8	1.03	26.16	1.51	38.35	1.23	31.2
7108L_1 1/4	*1 1/4	31.75	1 3/4	1.23	31.24	2.10	53.34	1.62	41.2
7108L_1 1/2	*1 1/2	38.10	2 1/8	1.47	37.33	2.54	64.52	1.97	50.0
7108L_2	*2	50.80	2 3/4	1.94	49.28	3.41	86.61	2.66	67.6

* Including low friction paste, See page 89

"D" - Dimension is minimum opening. Dimensions are for reference only, and are subject to change without notice.

**7121 L
PLUG**

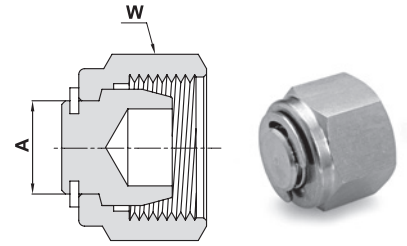

PLUGGING UNUSED PORT OF FITTING (METRIC)

Ordering Information	A		W
	mm		Hex. Flat mm
7121L_2	2		14
7121L_3	3		12
7121L_4	4		12
7121L_6	6		14
7121L_8	8		16
7121L_10	10		19
7121L_12	12		22
7121L_14	14		25
7121L_15	15		25
7121L_16	16		25
7121L_18	18		30
7121L_20	20		32
7121L_22	22		32
7121L_25	25		38
7121L_38	*38		60
7121L_50	*50		3 inch

PLUGGING UNUSED PORT OF FITTING (INCH)

Ordering Information	A		W
	inch	mm	Hex. Flat inch
7121L_1/16	1/16	1.58	5/16
7121L_1/8	1/8	3.17	7/16
7121L_3/16	3/16	4.76	1/2
7121L_1/4	1/4	6.35	9/16
7121L_5/16	5/16	7.93	5/8
7121L_3/8	3/8	9.52	11/16
7121L_1/2	1/2	12.70	7/8
7121L_5/8	5/8	15.87	1
7121L_3/4	3/4	19.05	1 1/8
7121L_7/8	7/8	22.22	1 1/4
7121L_1	1	25.40	1 1/2
7121L_1 1/4	*1 1/4	31.75	1 7/8
7121L_1 1/2	*1 1/2	38.10	2 1/4
7121L_2	*2	50.80	3

PLUG ASSEMBLY INSTRUCTIONS

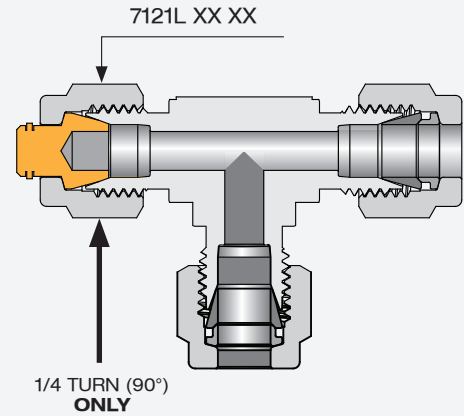

* Including low friction paste, See page 89

"D" - Dimension is minimum opening. Dimensions are for reference only, and are subject to change without notice.

**739 LF
FEMALE ADAPTER
TUBE TO PIPE**

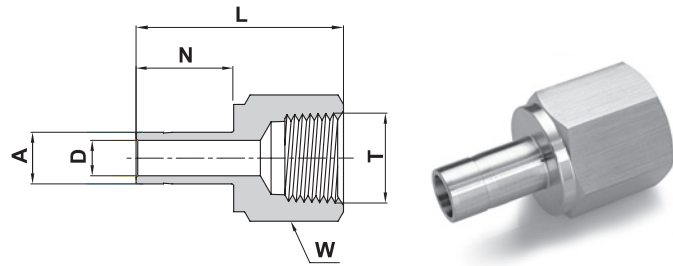

TUBE (METRIC) FEMALE PIPE

Ordering Information	A Tube O.D.	T (NPT)	D	W Hex. Flat	N	L
	mm	inch	mm	mm	mm	mm
739LF_ 3 X 1/8	3	1/8	2.1	14	13.5	31.5
739LF_ 3 X 1/4	3	1/4	2.1	19	13.5	35.3
739LF_ 4 X 1/4	4	1/4	2.2	19	14.2	35.0
739LF_ 6 X 1/8	6	1/8	4.0	14	15.7	32.5
739LF_ 6 X 1/4	6	1/4	4.0	19	15.7	37.1
739LF_ 6 X 3/8	6	3/8	4.0	22	15.7	39.6
739LF_ 6 X 1/2	6	1/2	4.0	27	15.7	45.5
739LF_ 8 X 1/8	8	1/8	5.6	14	16.8	34.3
739LF_ 8 X 1/4	8	1/4	5.6	19	16.8	37.6
739LF_ 8 X 1/2	8	1/2	5.6	27	16.8	46.0
739LF_ 10 X 1/4	10	1/4	7.1	19	17.5	38.1
739LF_ 10 X 3/8	10	3/8	7.1	22	17.5	40.1
739LF_ 10 X 1/2	10	1/2	7.1	27	17.5	46.5
739LF_ 12 X 1/4	12	1/4	8.8	19	23.1	43.4
739LF_ 12 X 3/8	12	3/8	8.8	22	23.1	45.5
739LF_ 12 X 1/2	12	1/2	8.8	27	23.1	52.3
739LF_ 16 X 3/8	16	3/8	12.7	24	24.7	48.0
739LF_ 16 X 1/2	16	1/2	12.7	27	24.7	53.1
739LF_ 20 X 1/2	20	1/2	15.1	27	26.6	56.0
739LF_ 20 X 3/4	20	3/4	15.1	35	26.6	56.0

"D" - Dimension is minimum opening. Dimensions are for reference only, and are subject to change without notice.

Cont'd next page

739 LF FEMALE ADAPTER TUBE TO PIPE

(Cont'd)

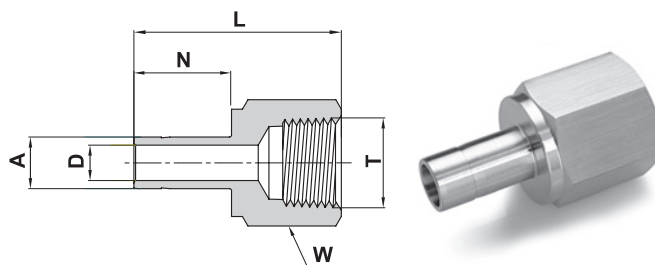

TUBE (INCH) FEMALE PIPE

Ordering Information	A Tube O.D.		T (NPT)	D		W Hex. Flat	N		L	
	inch	mm	inch	inch	mm	inch	inch	mm	inch	mm
739LF _ 1/8 X 1/8	1/8	3.17	1/8	.09	2.2	9/16	.53	13.45	1.24	31.5
739LF _ 1/8 X 1/4	1/8	3.17	1/4	.09	2.2	3/4	.53	13.45	1.39	35.3
739LF _ 3/16 X 1/4	3/16	4.76	1/4	.12	3.0	3/4	.56	14.20	1.41	35.8
739LF _ 1/4 X 1/8	1/4	6.35	1/8	.17	4.2	9/16	.62	15.75	1.30	33.0
739LF _ 1/4 X 1/4	1/4	6.35	1/4	.17	4.2	3/4	.62	15.75	1.46	37.1
739LF _ 1/4 X 3/8	1/4	6.35	3/8	.17	4.2	7/8	.62	15.75	1.55	39.4
739LF _ 1/4 X 1/2	1/4	6.35	1/2	.17	4.2	1 1/16	.62	15.75	1.79	45.5
739LF _ 5/16 X 1/4	5/16	7.93	1/4	.22	5.6	3/4	.66	16.75	1.48	37.6
739LF _ 3/8 X 1/8	3/8	9.52	1/8	.27	6.9	9/16	.69	17.50	1.35	34.3
739LF _ 3/8 X 1/4	3/8	9.52	1/4	.27	6.9	3/4	.69	17.50	1.50	38.1
739LF _ 3/8 X 3/8	3/8	9.52	3/8	.27	6.9	7/8	.69	17.50	1.59	40.4
739LF _ 3/8 X 1/2	3/8	9.52	1/2	.27	6.9	1 1/16	.69	17.50	1.84	46.7
739LF _ 1/2 X 1/4	1/2	12.70	1/4	.37	9.4	3/4	.91	23.10	1.71	43.4
739LF _ 1/2 X 3/8	1/2	12.70	3/8	.37	9.4	7/8	.91	23.10	1.79	45.5
739LF _ 1/2 X 1/2	1/2	12.70	1/2	.37	9.4	1 1/16	.91	23.10	2.05	52.1
739LF _ 5/8 X 1/2	5/8	15.87	1/2	.50	12.7	1 1/16	.97	24.65	2.09	53.1
739LF _ 3/4 X 1/2	3/4	19.05	1/2	.59	15.0	1 1/16	.97	24.65	2.08	52.8
739LF _ 3/4 X 3/4	3/4	19.05	3/4	.59	15.0	1 5/16	.97	24.65	2.16	54.9
739LF _ 3/4 X 1	3/4	19.05	1	.59	15.0	1 5/8	.97	24.65	2.30	58.4
739LF _ 1 X 3/4	1	25.40	3/4	.80	20.3	1 5/16	1.23	31.20	2.39	60.7
739LF _ 1 X 1	1	25.40	1	.80	20.3	1 5/8	1.23	31.20	2.53	64.3
739LF _ 1 1/4 X 1 1/4	* 1 1/4	31.75	1 1/4	1.02	25.9	2 1/8	1.73	43.82	3.06	77.7
739LF _ 1 1/2 X 1 1/2	* 1 1/2	38.10	1 1/2	1.25	31.8	2 3/8	2.14	54.33	3.50	88.9

* Supplied assembled with Nut and Ferrules. Including low friction paste, See page 89

"D" - Dimension is minimum opening. Dimensions are for reference only, and are subject to change without notice.

**739 LM
MALE ADAPTER
TUBE TO PIPE**

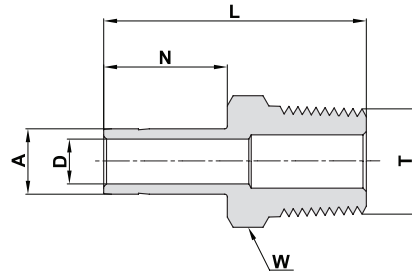

TUBE (METRIC) MALE PIPE

Ordering Information	A	T	D	W	N	L
	Tube O.D.	(NPT)		Hex. Flat		
	mm	inch	mm	mm	mm	mm
739LM _ 3 X 1/8	3	1/8	2.1	12	13.5	30.0
739LM _ 3 X 1/4	3	1/4	2.1	14	13.5	35.3
739LM _ 6 X 1/8	6	1/8	4.0	12	15.7	32.8
739LM _ 6 X 1/4	6	1/4	4.0	14	15.7	38.1
739LM _ 6 X 3/8	6	3/8	4.0	18	15.7	37.0
739LM _ 6 X 1/2	6	1/2	4.0	22	15.7	43.4
739LM _ 8 X 1/8	8	1/8	4.8	12	16.8	33.5
739LM _ 8 X 1/4	8	1/4	5.6	14	16.8	39.1
739LM _ 8 X 3/8	8	3/8	5.6	11/16 inch	16.8	37.8
739LM _ 8 X 1/2	8	1/2	5.6	22	16.8	43.0
739LM _ 10 X 1/4	10	1/4	7.1	9/16 inch	17.5	39.9
739LM _ 10 X 3/8	10	3/8	7.1	18	17.5	40.6
739LM _ 10 X 1/2	10	1/2	7.1	22	17.5	46.2
739LM _ 12 X 1/4	12	1/4	7.1	16	23.1	46.5
739LM _ 12 X 3/8	12	3/8	8.8	18	23.1	46.5
739LM _ 12 X 1/2	12	1/2	8.8	22	23.1	52.0
739LM _ 16 X 1/2	16	1/2	11.9	22	24.7	50.5
739LM _ 20 X 3/4	20	3/4	15.1	27	26.6	54.3

"D" - Dimension is minimum opening. Dimensions are for reference only, and are subject to change without notice.

Cont'd next page

**739 LM
MALE ADAPTER
TUBE TO PIPE**

(Cont'd)

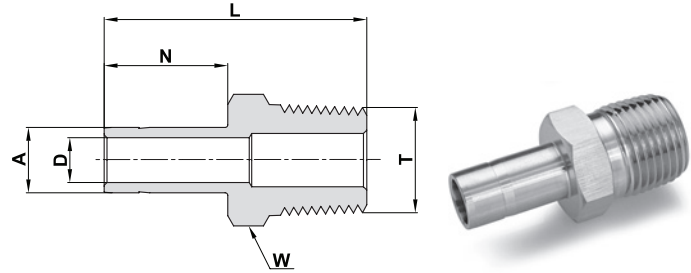

TUBE (INCH) MALE PIPE

Ordering Information	A Tube O.D.		T (NPT)	D		W Hex. Flat	N		L	
	inch	mm	inch	inch	mm	inch	inch	mm	inch	mm
739LM _ 1/8 X 1/8	1/8	3.17	1/8	.09	2.2	7/16	.53	13.45	1.16	29.5
739LM _ 1/8 X 1/4	1/8	3.17	1/4	.09	2.2	9/16	.53	13.45	1.37	34.8
739LM _ 3/16 X 1/8	3/16	4.76	1/8	.12	3.0	7/16	.56	14.20	1.19	30.2
739LM _ 3/16 X 1/4	3/16	4.76	1/4	.12	3.0	9/16	.56	14.20	1.40	35.6
739LM _ 1/4 X 1/8	1/4	6.35	1/8	.17	4.2	7/16	.62	15.75	1.25	31.8
739LM _ 1/4 X 1/4	1/4	6.35	1/4	.17	4.2	9/16	.62	15.75	1.46	37.1
739LM _ 1/4 X 3/8	1/4	6.35	3/8	.17	4.2	11/16	.62	15.75	1.49	37.9
739LM _ 1/4 X 1/2	1/4	6.35	1/2	.17	4.2	7/8	.62	15.75	1.71	43.4
739LM _ 5/16 X 1/8	5/16	7.93	1/8	.22	5.6	7/16	.66	16.75	1.29	32.7
739LM _ 5/16 X 1/4	5/16	7.93	1/4	.22	5.6	9/16	.66	16.75	1.50	38.1
739LM _ 3/8 X 1/8	3/8	9.52	1/8	.27	6.9	7/16	.69	17.50	1.32	33.5
739LM _ 3/8 X 1/4	3/8	9.52	1/4	.27	6.9	9/16	.69	17.50	1.53	38.9
739LM _ 3/8 X 3/8	3/8	9.52	3/8	.27	6.9	11/16	.69	17.50	1.56	39.6
739LM _ 3/8 X 1/2	3/8	9.52	1/2	.27	6.9	7/8	.69	17.50	1.78	45.2
739LM _ 1/2 X 1/4	1/2	12.70	1/4	.28	7.1	9/16	.91	23.10	1.75	44.5
739LM _ 1/2 X 3/8	1/2	12.70	3/8	.37	9.4	11/16	.91	23.10	1.78	45.2
739LM _ 1/2 X 1/2	1/2	12.70	1/2	.37	9.4	7/8	.91	23.10	2.00	50.8
739LM _ 5/8 X 3/8	5/8	15.87	3/8	.37	9.5	11/16	.97	24.65	1.81	47.6
739LM _ 5/8 X 1/2	5/8	15.87	1/2	.47	11.9	7/8	.97	24.65	2.06	52.3
739LM _ 5/8 X 3/4	5/8	15.87	3/4	.50	12.7	1 1/16	.97	24.65	2.03	52.3
739LM _ 3/4 X 1/2	3/4	19.05	1/2	.47	11.9	7/8	.97	24.65	2.06	52.3
739LM _ 3/4 X 3/4	3/4	19.05	3/4	.59	15.0	1 1/16	.97	24.65	2.06	52.3
739LM _ 3/4 X 1	3/4	19.05	1	.59	15.0	1 3/8	.97	24.65	2.28	57.3
739LM _ 7/8 X 3/4	7/8	22.22	3/4	.60	15.9	1 1/16	1.05	26.60	2.09	54.3
739LM _ 1 X 3/4	1	25.40	3/4	.60	15.8	1 1/16	1.30	33.00	2.31	58.7
739LM _ 1 X 1	1	25.40	1	.80	20.3	1 3/8	1.30	33.00	2.60	66.0
739LM _ 1 1/4 X 1 1/4	* 1 1/4	31.75	1 1/4	1.02	25.9	1 3/4	1.73	43.82	3.16	80.3
739LM _ 1 1/2 X 1 1/2	* 1 1/2	38.10	1 1/2	1.25	31.8	2 1/8	2.14	54.33	3.72	94.5

* Supplied assembled with Nut and Ferrules. Including low friction paste, See page 89

"D" - Dimension is minimum opening. Dimensions are for reference only, and are subject to change without notice.

**739 LMR
MALE ADAPTER
TUBE TO PIPE**

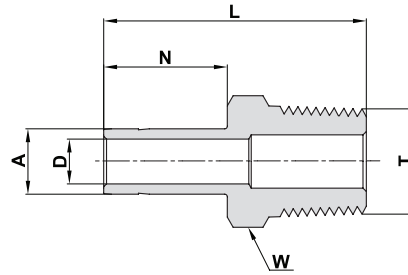

TUBE (METRIC) MALE PIPE

Ordering Information	A Tube O.D.		T (ISO)	D		W Hex. Flat	N		L
	mm	inch	inch	mm	mm	mm	mm	mm	
739LMR _ 6 X 1/8	6		R-1/8	4.0		12		15.7	32.8
739LMR _ 6 X 1/4	6		R-1/4	4.0		14		15.7	38.1
739LMR _ 6 X 1/2	6		R-1/2	4.0		22		15.7	43.4
739LMR _ 8 X 1/8	8		R-1/8	4.8		12		16.8	33.5
739LMR _ 8 X 1/4	8		R-1/4	5.6		14		16.8	39.1
739LMR _ 8 X 3/8	8		R-3/8	5.6		11/16 inch		16.8	37.8
739LMR _ 10 X 1/4	10		R-1/4	7.1		14		17.5	39.9
739LMR _ 10 X 3/8	10		R-3/8	7.1		18		17.5	40.6
739LMR _ 10 X 1/2	10		R-1/2	7.1		22		17.5	46.2
739LMR _ 12 X 1/4	12		R-1/4	7.1		16		23.1	46.5
739LMR _ 12 X 3/8	12		R-3/8	8.8		18		23.1	46.2
739LMR _ 12 X 1/2	12		R-1/2	8.8		22		23.1	52.0
739LMR _ 20 X 3/4	20		R-3/4	15.1		27		26.6	54.3

TUBE (INCH) MALE PIPE

Ordering Information	A Tube O.D.		T (ISO)	D		W Hex. Flat	N		L	
	inch	mm	inch	inch	mm	inch	inch	mm	inch	mm
739LMR _ 1/8 X 1/8	1/8	3.17	R-1/8	.09	2.2	7/16	.53	13.45	1.16	29.5
739LMR _ 1/8 X 1/4	1/8	3.17	R-1/4	.09	2.2	9/16	.53	13.45	1.37	34.8
739LMR _ 1/4 X 1/8	1/4	6.35	R-1/8	.17	4.2	7/16	.62	15.75	1.25	31.8
739LMR _ 1/4 X 1/4	1/4	6.35	R-1/4	.17	4.2	9/16	.62	15.75	1.46	37.1
739LMR _ 1/4 X 3/8	1/4	6.35	R-3/8	.17	4.2	11/16	.62	15.75	1.49	37.9
739LMR _ 1/4 X 1/2	1/4	6.35	R-1/2	.17	4.2	7/8	.62	15.75	1.71	43.4
739LMR _ 3/8 X 1/4	3/8	9.52	R-1/4	.27	6.9	9/16	.69	17.50	1.53	38.9
739LMR _ 3/8 X 3/8	3/8	9.52	R-3/8	.27	6.9	11/16	.69	17.50	1.56	39.6
739LMR _ 3/8 X 1/2	3/8	9.52	R-1/2	.27	6.9	7/8	.69	17.50	1.78	45.2
739LMR _ 1/2 X 1/4	1/2	12.70	R-1/4	.28	7.1	9/16	.91	23.10	1.75	44.5
739LMR _ 1/2 X 3/8	1/2	12.70	R-3/8	.37	9.4	11/16	.91	23.10	1.78	45.2
739LMR _ 1/2 X 1/2	1/2	12.70	R-1/2	.37	9.4	7/8	.91	23.10	20.0	50.8
739LMR _ 5/8 X 1/2	5/8	15.87	R-1/2	.47	11.9	7/8	.97	24.65	2.06	52.3
739LMR _ 3/4 X 1/2	3/4	19.05	R-1/2	.47	11.9	7/8	.97	24.65	2.06	52.3
739LMR _ 3/4 X 3/4	3/4	19.05	R-3/4	.59	15.0	1 1/16	.97	24.65	2.06	52.3
739LMR _ 1 X 1	1	25.40	R-1	.80	20.3	1 3/8	1.30	33.00	2.60	66.0

Reference Specifications:

DIN -ISO 2999
BS - 21JIS - B0203ISO - 7/1-BSP-T

55° Thread angle
Truncation of root and crest is round
Taper angle 1°47'

Designation:
Marking LR on Hex

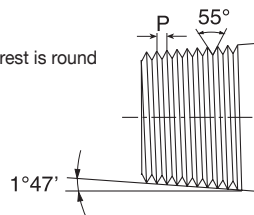

"D" - Dimension is minimum opening. Dimensions are for reference only, and are subject to change without notice.

**739 LN
WELD ADAPTER
TUBE TO PIPE**

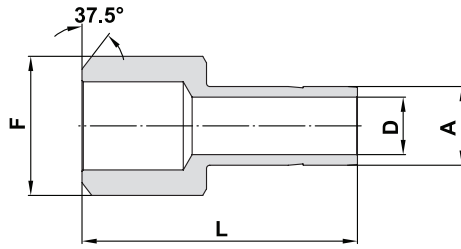

TUBE (INCH)

Ordering Information	A Tube O.D.		F Pipe Size		D		L	
	inch	mm	inch	mm	inch	mm	inch	mm
	739LN _ 1/4 X 1/4	1/4	6.35	1/4	13.70	.17	4.20	1.14
739LN _ 3/8 X 1/2	3/8	9.52	1/2	21.34	.27	6.85	1.46	37.08
739LN _ 1/2 X 1/2	1/2	12.7	1/2	21.34	.37	9.40	1.66	42.15
739LN _ 1/2 X 3/4	1/2	12.7	3/4	26.67	.37	9.40	1.68	42.67
739LN _ 3/4 X 3/4	3/4	19.05	3/4	26.67	.59	15.00	1.87	47.50

**739 LW
SOCKET WELD
ADAPTER**

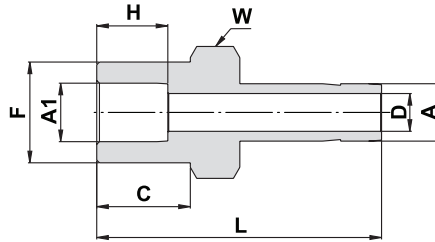

TUBE (METRIC) TO TUBE (INCH)

Ordering Information	A Tube O.D.	A1 Pipe Size	C	D	W	F	H	L
	mm	inch	mm	mm	inch	mm	mm	mm
739LW _ 6 X 1/4	6	1/4	10.4	4.0	1/2	11.2	7.9	31.7
739LW _ 10 X 1/4	10	1/4	10.4	4.8	9/16	11.2	7.9	34.0
739LW _ 10 X 3/8	10	3/8	11.9	7.1	5/8	15.8	9.7	36.0

TUBE (INCH) TO TUBE (INCH)

Ordering Information	A Tube O.D.		A1 Pipe Size		C		D		W		F		H		L	
	inch	mm	inch	mm	inch	mm	inch	mm	inch	mm	inch	mm	inch	mm	inch	mm
739LW _ 1/4 X 1/4	1/4	6.35	1/4	6.35	.41	10.41	.17	4.20	1/2	12.7	.44	11.18	.31	7.90	1.25	31.70
739LW _ 3/8 X 3/8	3/8	9.52	3/8	9.52	.47	11.94	.28	7.11	5/8	15.9	.62	15.75	.38	9.65	1.42	36.70
739LW _ 1/2 X 1/2	1/2	12.7	1/2	12.7	.47	11.94	.39	9.91	13/16	20.6	.75	19.05	.50	12.7	1.67	42.42

"D" - Dimension is minimum opening. Dimensions are for reference only, and are subject to change without notice.

**739 LMOB
MALE ADAPTER**

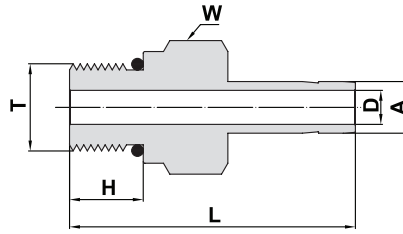

TUBE (INCH) TO SAE/MS STRAIGHT THREAD BOSS***

Ordering Information	A Tube O.D.		T Straight Thread UN	D		W		H		L		O-Ring**
	inch	mm	inch	inch	mm	inch	mm	inch	mm	inch	mm	
	739LMOB_ 1/8 X 5/16-24	1/8	3.18	5/16-24	.09	2.20	7/16	11.1	.30	7.62	1.20	
739LMOB_ 1/4 X 7/16-20	1/4	6.35	7/16-20	.17	4.20	9/16	14.3	.36	9.14	1.39	35.3	-904
739LMOB_ 1/4 X 9/16-18	1/4	6.35	9/16-18	.17	4.20	11/16	17.5	.39	9.90	1.42	36.07	-906
739LMOB_ 3/8 X 7/16-20	3/8	9.52	7/16-20	.20	5.10	9/16	14.3	.36	9.14	1.46	37.08	-904
739LMOB_ 3/8 X 9/16-18	3/8	9.52	9/16-18	.27	6.85	11/16	17.5	.39	9.90	1.52	38.61	-906
739LMOB_ 3/8 X 3/4-16	3/8	9.52	3/4-16	.27	6.85	7/8	22.2	.44	11.17	1.60	40.64	-908
739LMOB_ 1/2 X 9/16-18	1/2	12.7	9/16-18	.28	7.11	11/16	17.5	.39	9.90	1.74	44.20	-906
739LMOB_ 1/2 X 3/4-16	1/2	12.7	3/4-16	.37	9.40	7/8	22.2	.44	11.17	1.82	46.23	-908
739LMOB_ 5/8 X 7/8-14	5/8	15.87	7/8-14	.47	11.94	1	25.4	.50	12.70	1.94	49.28	-910
739LMOB_ 3/4 X 1 1/16-12	3/4	19.05	1 1/16-12	.59	15.00	1 1/4	31.8	.59	14.98	2.10	53.34	-912
739LMOB_ 1 X 1 5/16-12	1	25.40	1 5/16-12	.80	20.32	1 1/2	38.1	.59	14.98	2.41	61.21	-916
739LMOB_ 1 1/4 X 1 5/8-12	* 1 1/4	31.75	1 5/8-12	1.09	27.70	1 7/8	47.6	.59	15.10	2.69	68.33	-920
739LMOB_ 1 1/2 X 1 7/8-12	* 1 1/2	38.10	1 7/8-12	1.34	34.00	2 1/8	54.0	.59	15.10	3.06	77.72	-924

Designation: Marking LOB on Hex.

*** Per SAE J1926 and MS 16142. See page 78 for mounting dimensions.

** O-rings used are Viton 90 Durometer. Other O-ring materials are available on request.

* Supplied assembled with Nut + Front and Back Ferrule. Including low friction paste, See page 89.

"D" - Dimension is minimum opening. Dimensions are for reference only, and are subject to change without notice.

761 LFL
LET-LOK® TO AN ADAPTER

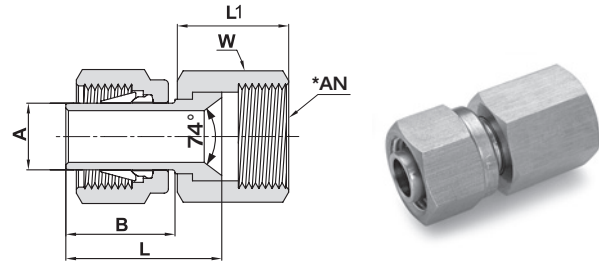

Ordering Information	A Tube O.D.		*AN Tube Flare Size		W Hex. Flat		L		L1		B	
	inch	mm	inch	mm	inch	mm	inch	mm	inch	mm	inch	mm
761LFL _ 1/8 X 1/8	1/8	3.17	1/8	3.17	3/8	.75	19.05	.54	13.71	.53	13.46	
761LFL _ 1/8 X 1/4	1/8	3.17	1/4	6.35	9/16	.75	19.05	.61	15.50	.53	13.46	
761LFL _ 1/4 X 1/4	1/4	6.35	1/4	6.35	9/16	.84	21.33	.61	15.50	.62	15.75	
761LFL _ 3/8 X 3/8	3/8	9.52	3/8	9.52	11/16	.98	24.89	.72	18.30	.69	17.53	
761LFL _ 1/2 X 1/2	1/2	12.70	1/2	12.70	7/8	1.25	31.75	.84	21.30	.91	23.11	

762 LFL
LET-LOK® TO AN UNION

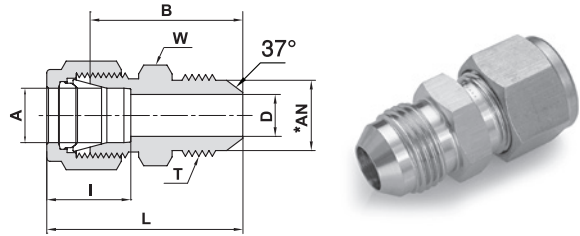

TUBE (INCH) TO TUBE (INCH)

Ordering Information	A Tube O.D.		*AN Tube Flare size		D		W Hex. Flat		B		L		I		T Straight Thread
	inch	mm	inch	mm	inch	mm	inch	mm	inch	mm	inch	mm	inch	mm	
762LFL _ 1/16 X 1/8	1/16	1.58	1/8	3.17	.05	1.27	7/16	.92	23.36	1.07	27.18	.34	8.6	5/16-24	
762LFL _ 1/8 X 1/8	1/8	3.17	1/8	3.17	.06	1.52	7/16	1.01	25.65	1.27	32.26	.50	12.7	5/16-24	
762LFL _ 1/8 X 1/4	1/8	3.17	1/4	6.35	.09	2.28	1/2	1.12	28.44	1.38	35.05	.50	12.7	7/16-20	
762LFL _ 1/4 X 1/4	1/4	6.35	1/4	6.35	.17	4.31	1/2	1.19	30.22	1.48	37.59	.60	15.2	7/16-20	
762LFL _ 3/8 X 1/4	3/8	9.52	1/4	6.35	.17	4.31	5/8	1.27	32.25	1.56	39.62	.66	16.8	7/16-20	
762LFL _ 3/8 X 3/8	3/8	9.52	3/8	9.52	.28	7.11	5/8	1.27	32.25	1.56	39.62	.66	16.8	9/16-18	
762LFL _ 1/2 X 1/2	1/2	12.70	1/2	12.70	.39	9.90	13/16	1.41	35.8	1.81	45.96	.90	22.9	3/4-16	
762LFL _ 3/4 X 3/4	3/4	19.05	3/4	19.05	.61	15.49	1 1/8	1.70	43.18	2.10	53.34	.96	24.4	1 1/16-12	
762LFL _ 1 X 1	1	25.40	1	25.40	.84	21.34	1 3/8	1.94	49.28	2.42	61.47	1.23	31.2	1 5/16-12	

774 LFL
LET-LOK® TO AN BULKHEAD UNION

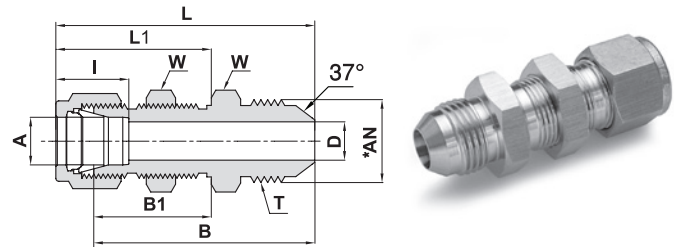

TUBE (INCH) TO TUBE (INCH)

Ordering Information	A Tube O.D.		*AN Tube Flare size		D		W Hex. Flat		B		B1		L		L1		T Straight Thread	Panel hole drill size		Max. panel thickness		I	
	inch	mm	inch	mm	inch	mm	inch	mm	inch	mm	inch	mm	inch	mm	inch	mm	inch	mm	inch	mm	inch	mm	
774LFL _ 1/4 X 1/4	1/4	6.35	1/4	6.35	.17	4.30	5/8	15.9	1.83	46.48	1.03	26.16	2.12	53.84	1.32	33.52	7/16-20	29/64	11.50	.40	10.16	.60	15.2
774LFL _ 3/8 X 3/8	3/8	9.52	3/8	9.52	.28	7.11	3/4	19.1	1.96	49.78	1.16	29.46	2.25	57.15	1.45	36.83	9/16-18	37/64	14.68	.44	11.17	.66	16.8
774LFL _ 1/2 X 1/2	1/2	12.70	1/2	12.70	.39	9.90	15/16	23.8	2.19	55.63	1.25	31.75	2.59	65.79	1.65	41.91	3/4-16	49/64	19.45	.50	12.70	.90	22.9
774LFL _ 3/4 X 3/4	3/4	19.05	3/4	19.05	.61	15.49	1 3/16	30.2	2.71	68.83	1.47	37.34	3.11	78.99	1.87	47.50	1 1/16-12	1 1/64	25.80	.66	16.76	.96	24.4
774LFL _ 1 X 1	1	25.40	1	25.40	.84	21.33	1 5/8	41.3	3.16	80.26	1.78	45.21	3.64	92.46	2.26	57.40	1 5/16-12	1 21/64	33.73	.75	19.05	.23	31.2

* Flare 37° per SAE J514. "D" - Dimension is minimum opening. Dimensions are for reference only, and are subject to change without notice.

**739 LTFL
MALE ADAPTER
TUBE TO AN**

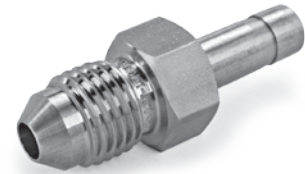
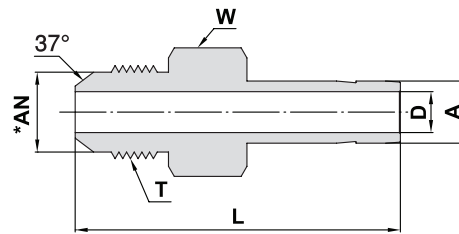

TUBE (INCH) TO TUBE (INCH)

Ordering Information	A Tube O.D.		*AN Thread Flare Size		D		W		L		T Straight Thread
	inch	mm	inch	mm	inch	mm	inch	mm	inch	mm	
739LTFL _ 1/4 X 1/4	1/4	6.35	1/4	6.35	.17	4.20	1/2	12.7	1.46	37.08	7/16-20
739LTFL _ 3/8 X 1/4	3/8	9.52	1/4	6.35	.17	4.20	1/2	12.7	1.53	38.86	7/16-20
739LTFL _ 3/8 X 3/8	3/8	9.52	3/8	9.52	.28	7.11	5/8	15.9	1.56	39.62	9/16-18
739LTFL _ 1/2 X 1/2	1/2	12.7	1/2	12.7	.39	9.90	13/16	20.6	1.91	48.51	3/4-16
739LTFL _ 5/8 X 5/8	5/8	15.87	5/8	15.87	.484	12.30	15/16	23.8	2.10	53.20	7/8-14
739LTFL _ 3/4 X 3/4	3/4	19.05	3/4	19.05	.59	15.00	1 1/8	28.6	2.21	56.13	1 1/16-12
739LTFL _ 1 X 1	1	25.40	1	25.40	.80	20.32	1 3/8	34.9	2.58	65.53	1 5/16-12

* Flare 37° per SAE J514.

"D" - Dimension is minimum opening. Dimensions are for reference only, and are subject to change without notice.

CHROMATOGRAPH FITTINGS

961 L MALE NUT (INCH)

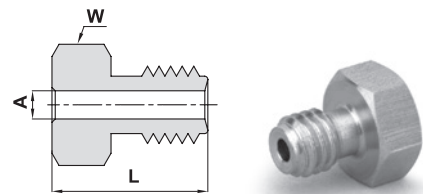

Ordering Information	A Tube O.D.		W Hex. Flat		L	
	inch	mm	inch	mm	inch	mm
961L_ 1/16	1/16	1.58	1/4		.38	9.50

962 L UNION (INCH)

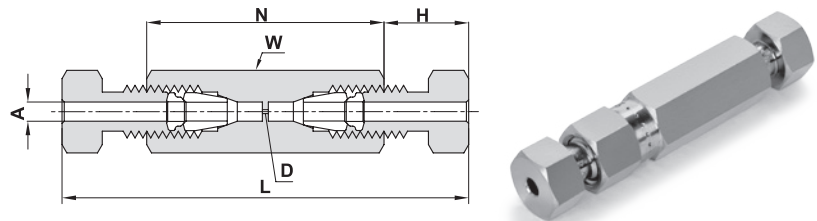

Ordering Information	A Tube O.D.		D		W Hex. Flat		N		H		L		Dead Space
	inch	mm	inch	mm	inch	mm	inch	mm	inch	mm	inch	mm	
962L_ 1/16	1/16	1.58	.013	.33	1/4		.84	21.34	.20	5.08	1.25	31.75	6.6 X 10 ⁻⁵ CC

963 L REDUCING UNION (INCH)

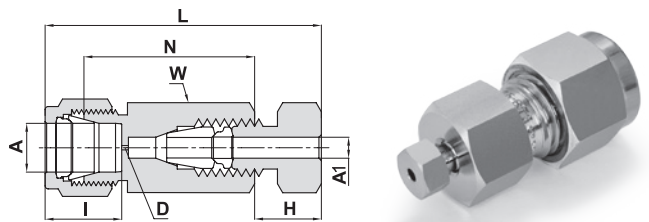

Ordering Information	A Tube O.D.		A1 Tube O.D.		D		W Hex. Flat		N		L		H		I		Dead Space
	inch	mm	inch	mm	inch	mm	inch	mm	inch	mm	inch	mm	inch	mm	inch	mm	
963L_ 1/4 X 1/16	1/4	6.35	1/16	1.58	.013	.33	1/2		.75	19.05	1.24	31.50	.20	5.08	.60	15.2	6.8 X 10 ⁻⁵ CC
963L_ 3/8 X 1/16	3/8	9.52	1/16	1.58	.013	.33	5/8		.81	20.57	1.30	33.02	.20	5.08	.66	16.8	6.8 X 10 ⁻⁵ CC

964 L UNION TEE (INCH)

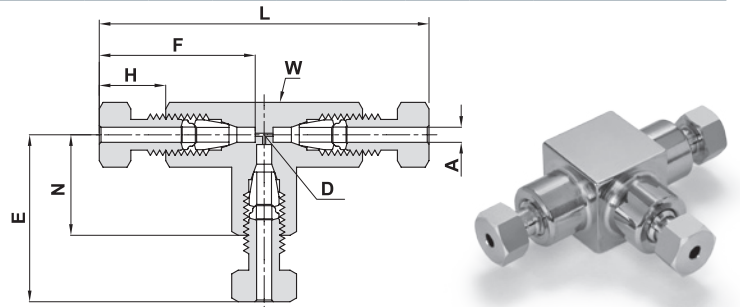

Ordering Information	A Tube O.D.		D		W Wrench Flat		N		H		F		E		L		Dead Space
	inch	mm	inch	mm	inch	mm	inch	mm	inch	mm	inch	mm	inch	mm	inch	mm	
964L_ 1/16	1/16	1.58	.013	.33	3/8	9.52	.45	11.43	.20	5.08	.61	15.49	.65	16.51	1.30	33.02	2.8 X 10 ⁻⁴ CC

"D" - Dimension is minimum opening. Dimensions are for reference only, and are subject to change without notice.

POSITIONABLESPER SAE
J1926 AND MS 16142

769 LOB
MALE ELBOW

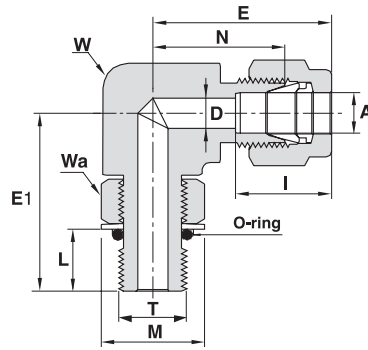

TUBE TO SAE/MS STRAIGHT THREAD BOSS (POSITIONABLE)*

Ordering Information	A		T	D		W		Wa	N		E		E1		L		M		I	O-ring**	
	inch	mm	inch	inch	mm	inch	mm	inch	inch	mm	inch	mm	inch	mm	inch	mm	inch	mm	inch	mm	Dash No.
769LOB SS 1/4 X 7/16-20 POS.	1/4	6.35	7/16-20	.19	4.8	1/2	12.7	9/16	.83	21.10	1.12	28.45	1.12	28.45	.39	9.9	.65	16.5	.60	15.2	-904
769LOB SS 1/4 X 9/16-18 POS.	1/4	6.35	9/16-18	.19	4.8	5/8	15.9	11/16	.91	23.11	1.20	30.48	1.27	32.26	.44	11.2	.79	20.1	.60	15.2	-906
769LOB SS 3/8 X 7/16-20 POS.	3/8	9.52	7/16-20	.20	5.1	5/8	15.9	9/16	.97	24.64	1.26	32.00	1.12	28.45	.39	9.9	.65	16.5	.66	16.8	-904
769LOB SS 3/8 X 9/16-18 POS.	3/8	9.52	9/16-18	.28	7.1	5/8	15.9	11/16	.97	24.64	1.26	32.0	1.27	32.26	.44	11.2	.79	20.1	.66	16.8	-906
769LOB SS 3/8 X 3/4-16 POS.	3/8	9.52	3/4-16	.28	7.1	13/16	20.6	7/8	1.08	27.43	1.37	34.80	1.49	37.85	.50	12.7	1.01	25.7	.66	16.8	-908
769LOB SS 1/2 X 9/16-18 POS.	1/2	12.70	9/16-18	.28	7.1	13/16	20.6	11/16	1.08	27.43	1.48	37.59	1.38	35.05	.44	11.2	.79	20.1	.90	22.9	-906
769LOB SS 1/2 X 3/4-16 POS.	1/2	12.70	3/4-16	.41	10.4	13/16	20.6	7/8	1.08	27.43	1.48	37.59	1.49	37.85	.50	12.7	1.01	25.7	.90	22.9	-908
769LOB SS 3/4 X 1 1/16-12 POS.	3/4	19.05	1 1/16-12	.62	15.8	1 1/16	27.0	1 1/4	1.23	31.24	1.63	41.40	1.92	48.77	.66	16.8	1.44	36.7	.96	24.4	-912
769LOB SS 1 X 1 1/16-12 POS.	1	25.40	1 1/16-12	.62	15.8	1 3/8	34.9	1 1/4	1.51	38.35	1.99	50.55	2.05	52.07	.66	16.8	1.44	36.7	1.23	31.2	-912
769LOB SS 1 X 1 5/16-12 POS.	1	25.40	1 5/16-12	.88	22.3	1 3/8	34.9	1 1/2	1.51	38.35	1.99	50.55	2.11	53.59	.66	16.8	1.73	44.0	1.23	31.2	-916

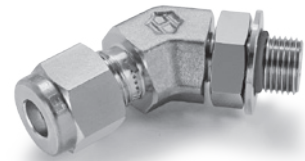
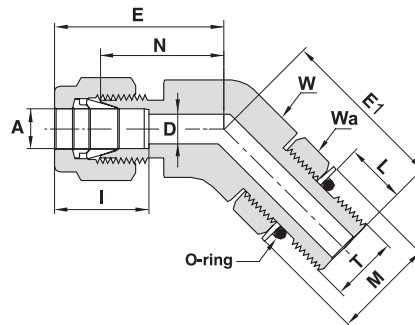

769 LOB 45°
MALE ELBOW 45°

TUBE TO SAE/MS STRAIGHT THREAD BOSS (POSITIONABLE)*

Ordering Information	A		T	D		W		Wa	N		E		E1		L		M		I	O-ring**	
	inch	mm	inch	inch	mm	inch	mm	inch	inch	mm	inch	mm	inch	mm	inch	mm	inch	mm	inch	mm	Dash No.
769LAOB SS 1/4 X 7/16-20 POS.	1/4	6.35	7/16-20	.19	4.8	9/16	14.3	9/16	.72	18.29	1.01	25.65	1.01	25.65	.39	9.9	.65	16.5	.60	15.2	-904
769LAOB SS 3/8 X 9/16-18 POS.	3/8	9.52	9/16-18	.28	7.1	13/16	20.6	11/16	.81	20.57	1.10	27.94	1.06	27.00	.44	11.2	.79	20.1	.66	16.8	-906

* Per SAE J1926 and MS 16142. See page 78 for mounting dimensions. ** O-rings used are Viton 90 Durometer. Other O-ring materials are available on request.
 "D" - Dimension is minimum opening. Dimensions are for reference only, and are subject to change without notice.

POSITIONABLES
PER SAE J1926 AND MS 16142

771 LOB
MALE RUN TEE

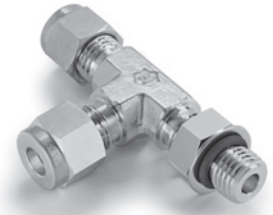
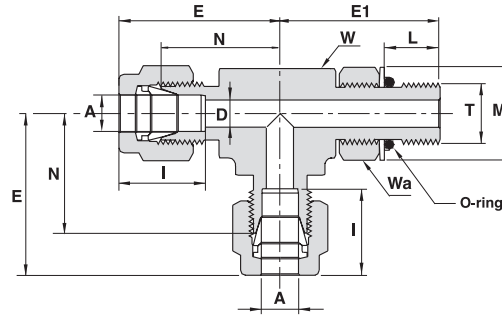

TUBE TO SAE/MS STRAIGHT THREAD BOSS (POSITIONABLE)*

Ordering Information	A		T	D		W		Wa	N		E		E1		L		M		I	O-ring**	
	Tube O.D.		SAE/MS			Wrench Flat		Hex. Flat												Dash No.	
	inch	mm	inch	inch	mm	inch	mm	inch	inch	mm	inch	mm	inch	mm	inch	mm	inch	mm	inch	mm	
771LOB SS 1/4 X 7/16-20 POS.	1/4	6.35	7/16-20	.19	4.8	1/2	12.7	9/16	.83	21.10	1.12	28.45	1.12	28.45	.39	9.9	.65	16.5	.60	15.2	-904
771LOB SS 3/8 X 9/16-18 POS.	3/8	9.52	9/16-18	.28	7.1	5/8	15.9	11/16	.97	24.64	1.26	32.00	1.27	32.26	.44	11.2	.79	20.1	.66	16.8	-906

* Per SAE J1926 and MS 16142. See page 78 for mounting dimensions.
** O-rings used are Viton 90 Durometer. Other O-ring materials are available on request.

772 LOB
MALE BRANCH TEE

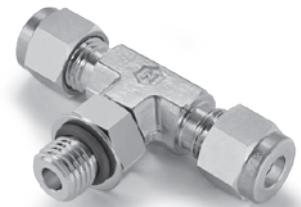
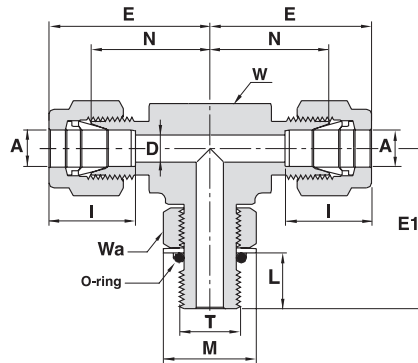

TUBE TO SAE/MS STRAIGHT THREAD BOSS (POSITIONABLE)*

Ordering Information	A		T	D		W		Wa	N		E		E1		L		M		I	O-ring**	
	Tube O.D.		SAE/MS			Wrench Flat		Hex. Flat												Dash No.	
	inch	mm	inch	inch	mm	inch	mm	inch	inch	mm	inch	mm	inch	mm	inch	mm	inch	mm	inch	mm	
772LOB SS 1/4 X 7/16-20 POS.	1/4	6.35	7/16-20	.19	4.8	1/2	12.7	9/16	.83	21.10	1.12	28.45	1.12	28.45	.39	9.9	.65	16.5	.60	15.2	-904
772LOB SS 3/8 X 9/16-18 POS.	3/8	9.52	9/16-18	.28	7.1	5/8	15.9	11/16	.97	24.64	1.26	32.00	1.27	32.26	.44	11.2	.79	20.1	.66	16.8	-906

* Per SAE J1926 and MS 16142. See page 78 for mounting dimensions.
** O-rings used are Viton 90 Durometer. Other O-ring materials are available on request.

"D" - Dimension is minimum opening. Dimensions are for reference only, and are subject to change without notice.

DIMENSIONS

FOR SAE J1926 &
MS 16142 BOSS

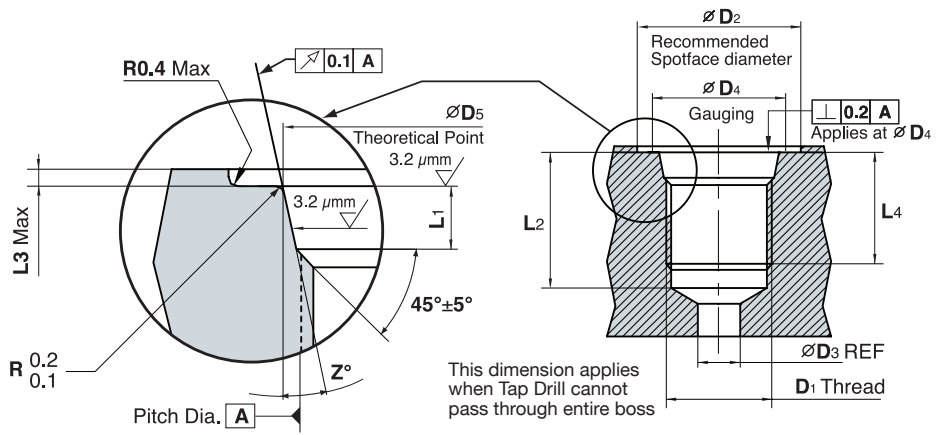

MOUNTING DIMENSIONS FOR O-SEAL CONNECTORS (SAE/MS)

TUBE O.D.		D1 Thread Size	D2 Min Diameter ±0.05	D3 Min Diameter	D4 Min	D5 ±0.05	L1 ±0.20	L2 Min	L3 Max	L4 Min Full Thread	Z° ±1°
inch	mm	inch	mm	mm	mm	mm	mm	mm	mm	mm	
1/8	3.17	5/16 - 24 UNF - 2B	17	1.6	11	9.15	2.1	12	1.6	10	12
3/16	4.76	3/8 - 24 UNF - 2B	19	3.5	13	10.75	2.1	12	1.6	10	12
1/4	6.35	7/16 - 20 UNF - 2B	21	4.5	15	12.45	2.6	14	1.6	11.5	12
5/16	7.93	1/2 - 20 UNF - 2B	23	6	16	14.05	2.6	14	1.6	11.5	12
3/8	9.52	9/16 - 18 UNF - 2B	25	7.5	18	15.70	2.7	15.5	1.6	12.7	12
1/2	12.70	3/4 - 16 UNF - 2B	30	10	22	20.65	2.7	17.5	2.4	14.3	15
5/8	15.87	7/8 - 14 UNF - 2B	34	12.5	26	24	2.7	20	2.4	16.7	15
3/4	19.05	1 1/16 - 12 UNF - 2B	41	16	32	29.2	3.5	23	2.4	19	15
7/8	22.22	1 3/16 - 12 UN - 2B	45	18	35	32.4	3.5	23	2.4	19	15
1	25.40	1 5/16 - 12 UN - 2B	49	21	38	35.55	3.5	23	3.2	19	15
1 1/4	31.75	1 5/8 - 12 UN - 2B	58	27	48	43.55	3.5	23	3.2	19	15
1 1/2	38.10	1 7/8 - 12 UN - 2B	65	33	54	49.9	3.5	23	3.2	19	15
2	50.80	2 1/2 - 12 UN - 2B	88	45	70	65.75	3.5	23	3.2	19	15

INSTALLATION INSTRUCTIONS

Figure 1	Figure 2	Figure 3	Figure 4
Locking backed off	Fitting install hand tight	Fittings backed-off for alignment (1 turn maximum)	Fitting locknut tight to appropriate torque
Lubricate the O-ring by inserting it into the groove adjacent to the face of the metal back-up washer which is assembled at the extreme end of the groove as shown in Figure 1.	Install the fitting into the S.A.E. straight thread boss, figure 2, until the metal back-up washer contacts the face of the boss as shown in Figure 2.	Position the fitting by turning it counter clockwise up to a maximum of one turn (see Figure 3).	Holding the pad of the fitting with a spanner, tighten the locknut and washer against the face as shown in Figure 4.

Dimensions are for reference only, and are subject to change without notice.

POSITIONABLES

ISO PARALLEL THREAD

769 LG MALE ELBOW

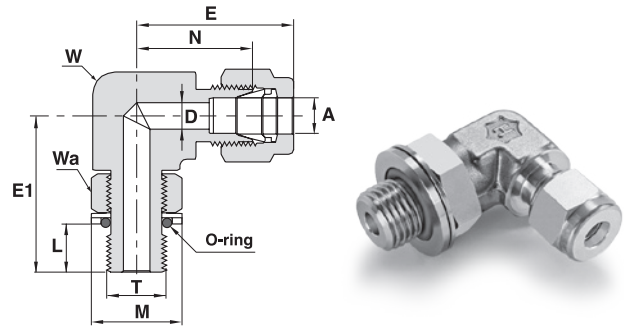

TUBE (METRIC) TO ISO PARALLEL THREAD (POSITIONABLE)*

Ordering Information	A Tube O.D.		T (ISO)	D Wrench Flat		Wa Hex. Flat		N		E	E1		L		M		I		O-ring**
	mm	inch	inch	mm	inch	mm	inch	mm	mm	mm	mm	mm	mm	mm	mm	mm	mm	mm	Dash No.
769LG SS 6 X 1/8 POS.	6		G-1/8-28	4.0	1/2	12.7	9/16	19.6	27.0	27.0	26.4	8.1	17.3	15.3					***
769LG SS 6 X 1/4 POS.	6		G-1/4-19	4.8	5/8	15.9	3/4	21.6	29.0	29.0	32.2	9.1	22.9	15.3					-111
769LG SS 8 X 1/8 POS.	8		G-1/8-28	4.0	5/8	15.9	9/16	21.3	28.8	28.8	27.4	8.1	17.3	16.2					***
769LG SS 8 X 1/4 POS.	8		G-1/4-19	5.9	5/8	15.9	3/4	22.4	29.9	29.9	32.2	9.1	22.9	16.2					-111
769LG SS 10 X 1/4 POS.	10		G-1/4-19	5.9	13/16	20.6	3/4	25.9	33.5	33.5	35.0	9.1	22.9	17.2					-111
769LG SS 10 X 3/8 POS.	10		G-3/8-19	7.9	13/16	20.6	7/8	25.9	33.5	33.5	37.1	9.4	26.4	17.2					-113
769LG SS 12 X 1/4 POS.	12		G-1/4-19	5.9	13/16	20.6	3/4	25.9	36.0	36.0	35.0	9.1	22.9	22.8					-111
769LG SS 12 X 3/8 POS.	12		G-3/8-19	7.9	13/16	20.6	7/8	25.9	36.0	36.0	37.1	9.4	26.4	22.8					-113
769LG SS 12 X 1/2 POS.	12		G-1/2-14	9.5	15/16	23.8	1 1/16	27.9	38.0	38.0	43.4	13.0	32.0	22.8					-593

TUBE (INCH) TO ISO PARALLEL THREAD (POSITIONABLE)*

Ordering Information	A Tube O.D.		T (ISO)	D Wrench Flat		Wa Hex. Flat		N		E	E1		L		M		I		O-ring**		
	inch	mm	inch	inch	mm	inch	mm	inch	mm	inch	mm	inch	mm	inch	mm	inch	mm	inch	mm	Dash No.	
769LG SS 1/4 X 1/8 POS.	1/4	6.35	G-1/8-28	.16	4.0	1/2	12.7	9/16	.77	19.60	1.06	26.9	1.04	26.4	.32	8.1	.68	17.3	.60	15.2	***
769LG SS 1/4 X 1/4 POS.	1/4	6.35	G-1/4-19	.19	4.8	5/8	15.9	3/4	.85	21.60	1.14	28.9	1.27	32.2	.36	9.1	.90	22.9	.60	15.2	-111
769LG SS 1/4 X 1/2 POS.	1/4	6.35	G-1/2-14	.19	4.8	15/16	23.8	1 1/16	.96	24.38	1.25	31.8	1.71	43.4	.51	13.0	1.26	32.0	.60	15.2	-593
769LG SS 3/8 X 1/4 POS.	3/8	9.52	G-1/4-19	.23	5.9	5/8	15.9	3/4	.91	23.11	1.20	30.5	1.27	32.2	.36	9.1	.90	22.9	.66	16.8	-111
769LG SS 3/8 X 3/8 POS.	3/8	9.52	G-3/8-19	.28	7.1	13/16	20.6	7/8	1.02	25.91	1.31	33.3	1.46	37.1	.37	9.4	1.04	26.4	.66	16.8	-113
769LG SS 1/2 X 1/4 POS.	1/2	12.70	G-1/4-19	.23	5.9	13/16	20.6	3/4	1.02	25.91	1.42	36.1	1.27	32.2	.36	9.1	.90	22.9	.90	22.9	-111
769LG SS 1/2 X 3/8 POS.	1/2	12.70	G-3/8-19	.31	7.9	13/16	20.6	7/8	1.02	25.91	1.42	36.1	1.46	37.1	.37	9.4	1.04	26.4	.90	22.9	-113
769LG SS 1/2 X 1/2 POS.	1/2	12.70	G-1/2-14	.41	10.4	15/16	23.8	1 1/16	1.10	27.94	1.50	38.1	1.71	43.4	.51	13.0	1.26	32.0	.90	22.9	-593
769LG SS 5/8 X 1/2 POS.	5/8	15.87	G-1/2-14	.47	11.9	15/16	23.8	1 1/16	1.10	27.94	1.50	38.1	1.71	43.4	.51	13.0	1.26	32.0	.96	24.4	-593

* Per: DIN - ISO 228/1
BS - 2779
JIS - B0202
ISO - 228/1-BSP-P

** O-rings used are Viton 90 Durometer. Other O-ring materials are available on request.

*** Not standard O-ring size.

"D" - Dimension is minimum opening. Dimensions are for reference only, and are subject to change without notice.

POSITIONABLES

ISO PARALLEL THREAD

769 LG 45° MALE ELBOW 45°

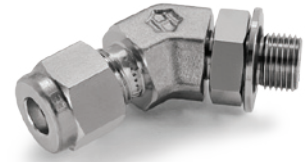
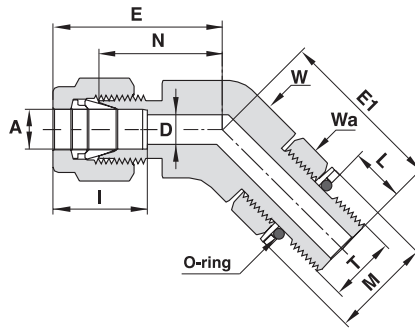

TUBE (METRIC) TO ISO PARALLEL THREAD (POSITIONABLE)*

Ordering Information	A Tube O.D.		T (ISO)	D		W Wrench Flat		Wa Hex. Flat	N		E		E1		L		M		I	O-ring**
	mm	inch	inch	mm	inch	mm	inch	mm	mm	mm	mm	mm	mm	mm	mm	mm	mm	mm	Dash No.	
769LAG SS 6 X 1/8 POS.	6		G-1/8-28	4.0		9/16	14.3	9/16	17.5		24.9		24.0		8.1		17.3		15.3	***

TUBE (INCH) TO ISO PARALLEL THREAD (POSITIONABLE)*

Ordering Information	A Tube O.D.		T (ISO)	D		W Wrench Flat		Wa Hex. Flat	N		E		E1		L		M		I	O-ring**	
	inch	mm	inch	inch	mm	inch	mm	inch	inch	mm	inch	mm	inch	mm	inch	mm	inch	mm	inch	mm	Dash No.
769LAG SS 1/4 X 1/8 POS.	1/4	6.35	G-1/8-28	.16	4.0	9/16	14.3	9/16	.69	17.5	.98	24.9	.94	24.0	.32	8.1	.68	17.3	.60	15.2	***

771 LG MALE RUN TEE

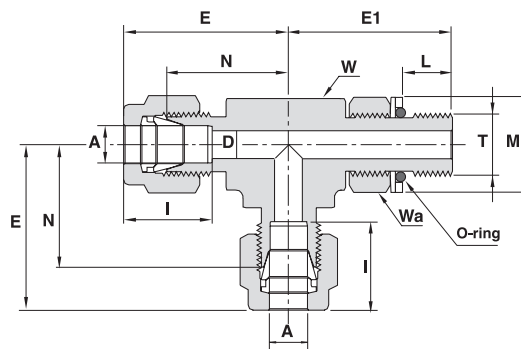

TUBE (METRIC) TO ISO PARALLEL THREAD (POSITIONABLE)*

Ordering Information	A Tube O.D.		T (ISO)	D		W Wrench Flat		Wa Hex. Flat	N		E		E1		L		M		I	O-ring**
	mm	inch	inch	mm	inch	mm	inch	mm	mm	mm	mm	mm	mm	mm	mm	mm	mm	mm	Dash No.	
771LG SS 6 X 1/8 POS.	6		G-1/8-28	4.0		1/2	12.7	9/16	19.6		27.0		26.4		8.1		17.3		15.3	***
771LG SS 6 X 1/4 POS.	6		G-1/4-19	4.8		5/8	15.9	3/4	21.6		29.0		32.2		9.1		22.9		15.3	-111
771LG SS 8 X 1/4 POS.	8		G-1/4-19	5.9		5/8	15.9	3/4	22.4		29.9		32.2		9.1		22.9		16.2	-111
771LG SS 10 X 1/4 POS.	10		G-1/4-19	5.9		15/16	23.8	3/4	25.9		33.5		35.0		9.1		22.9		17.2	-111

TUBE (INCH) TO ISO PARALLEL THREAD (POSITIONABLE)*

Ordering Information	A Tube O.D.		T (ISO)	D		W Wrench Flat		Wa Hex. Flat	N		E		E1		L		M		I	O-ring**	
	inch	mm	inch	inch	mm	inch	mm	inch	inch	mm	inch	mm	inch	mm	inch	mm	inch	mm	inch	mm	Dash No.
771LG SS 1/4 X 1/8 POS.	1/4	6.35	G-1/8-28	.16	4.0	1/2	12.7	9/16	.77	19.6	1.06	26.9	1.04	26.4	.32	8.1	.68	17.3	.60	15.2	***
771LG SS 1/4 X 1/4 POS.	1/4	6.35	G-1/4-19	.19	4.8	5/8	15.9	3/4	.85	21.6	1.14	28.9	1.27	32.2	.36	9.1	.90	22.9	.60	15.2	-111
771LG SS 3/8 X 1/4 POS.	3/8	9.52	G-1/4-19	.23	5.9	5/8	15.9	3/4	.91	23.1	1.20	30.5	1.27	32.2	.36	9.1	.90	22.9	.66	16.8	-111

* Per: DIN - ISO 228/1
BS - 2779
JIS - B0202
ISO - 228/1-BSP-P

** O-rings used are Viton 90 Durometer. Other O-ring materials are available on request.

*** Not standard O-ring size.

"D" - Dimension is minimum opening. Dimensions are for reference only, and are subject to change without notice.

POSITIONABLES
ISO PARALLEL THREAD

772 LG
MALE BRANCH TEE

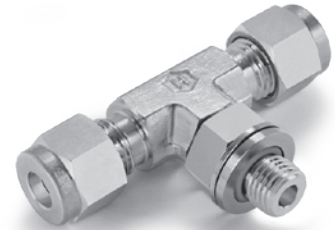
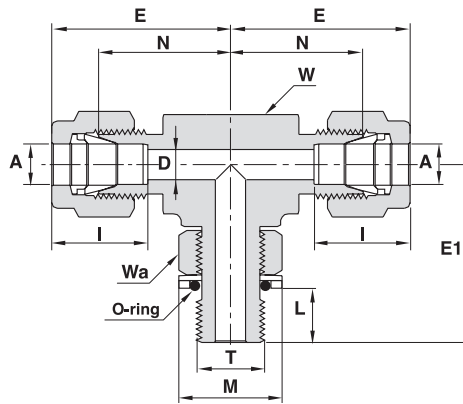

TUBE (METRIC) TO ISO PARALLEL THREAD (POSITIONABLE)*

Ordering Information	A		T	D		W		Wa	N		E	E1		L		M	I	O-ring**
	Tube O.D.		(ISO)	mm	inch	mm	inch	mm	inch	mm	mm	mm	mm	mm	mm	mm	mm	mm
772LG SS 6 X 1/8 POS.	6		G-1/8-28	4.0	1/2	12.7	9/16	19.6	27.0	26.4	8.1	17.3	15.3	***				
772LG SS 6 X 1/4 POS.	6		G-1/4-19	4.8	5/8	15.9	3/4	21.6	29.0	32.2	9.1	22.9	15.3	-111				
772LG SS 8 X 1/4 POS.	8		G-1/4-19	5.9	5/8	15.9	3/4	22.4	29.9	32.2	9.1	22.9	16.2	-111				
772LG SS 10 X 1/4 POS.	10		G-1/4-19	5.9	15/16	23.8	3/4	25.9	33.5	35.0	9.1	22.9	17.2	-111				

TUBE (INCH) TO ISO PARALLEL THREAD (POSITIONABLE)*

Ordering Information	A		T	D		W		Wa	N		E	E1		L		M	I	O-ring**			
	Tube O.D.		(ISO)	inch	mm	inch	mm	inch	mm	inch	mm	inch	mm	inch	mm	inch	mm	inch	mm	Dash No.	
772LG SS 1/4 X 1/8 POS.	1/4	6.35	G-1/8-28	0.16	4.0	1/2	12.7	9/16	0.77	19.6	1.06	26.9	1.04	26.4	0.32	8.1	0.68	17.3	0.60	15.2	***
772LG SS 1/4 X 1/4 POS.	1/4	6.35	G-1/4-19	0.19	4.8	5/8	15.9	3/4	0.85	21.6	1.14	28.9	1.27	32.2	0.36	9.1	0.90	22.9	0.60	15.2	-111
772LG SS 3/8 X 1/4 POS.	3/8	9.52	G-1/4-19	0.23	5.9	5/8	15.9	3/4	0.91	23.1	1.20	30.5	1.27	32.2	0.36	9.1	0.90	22.9	0.66	16.8	-111

* Per: DIN - ISO 228/1
BS - 2779
JIS - B0202
ISO - 228/1-BSP-P

** O-rings used are Viton 90 Durometer. Other O-ring materials are available on request.

*** Not standard O-ring size.

"D" - Dimension is minimum opening. Dimensions are for reference only, and are subject to change without notice.

ISO PARALLEL THREAD PER B.S. 2779

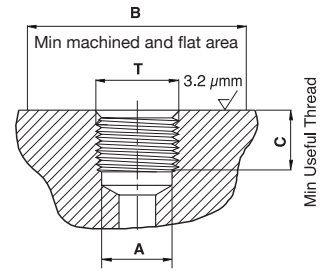

MOUNTING DIMENSIONS CONNECTORS

T Female	A Thread Minor Diameter				B Min Machined and Flat Area		C Min Useful Thread	
	max		min		inch	mm	inch	mm
	inch	mm	inch	mm				
G-1/8-28	.337	8.566	.348	8.848	.68	17.3	.31	7.87
G-1/4-19	.450	11.445	.468	11.890	.90	22.9	.47	11.94
G-3/8-19	.588	14.950	.606	15.395	1.04	26.4	.47	11.94
G-1/2-14	.733	18.631	.755	19.172	1.26	32.0	.55	13.97

INSTALLATION INSTRUCTIONS

Figure 1	Figure 2	Figure 3	Figure 4
Locking backed off	Fitting install hand tight	Fittings backed-off for alignment (1 turn maximum)	Fitting locknut tight to appropriate torque
Lubricate O-ring by inserting it in the groove adjacent to the face of the metal back-up washer which is assembled at the extreme end of the groove as shown in Figure 1.	Install the fitting into the S.A.E. straight thread boss, Figure 2, until the metal back-up washer contacts the face of the boss as shown in Figure 2.	Position the fitting by turning counter clockwise up to maximum of one turn. See Figure 3.	Holding the pad of the fitting with a wrench, tighten the locknut and washer against the face as shown in Figure 4.

HAM-LET DIELECTRIC FITTINGS

Dielectric fittings are designed to insulate subsystems from electrical current, voltages and static charges

MATERIAL OF CONSTRUCTION

1. Body: A.I.S.I. 316.
2. Insulators: Polyamide-Imide.
3. O-Ring: Viton 70 Durometer.
4. Ring: PTFE.

WORKING CONDITIONS:

1. Pressure rating: 5000 psi
2. Temperature rating: -40°C to 93°C (-40°F to 200°F).
3. Electrical resistance at 20°C-25°C (68°F-77°F): 10X10⁶Ω at 30V DC.

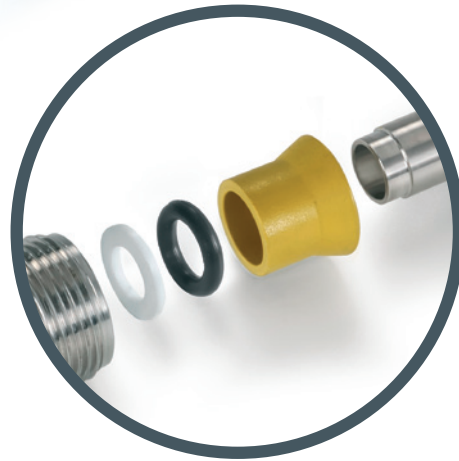
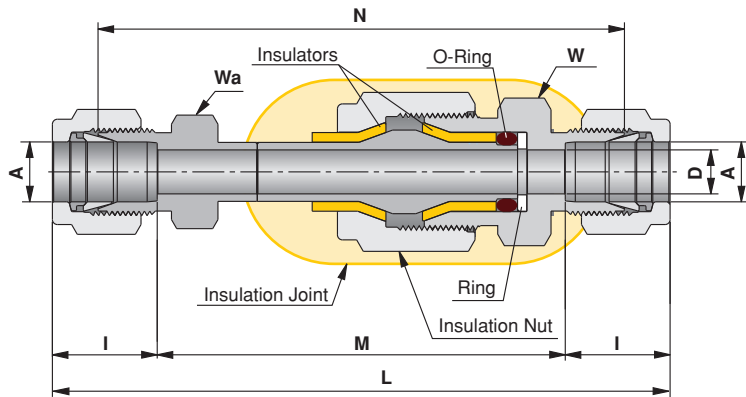

TUBE (METRIC) TO TUBE (METRIC)

Ordering Information	A Tube O.D.		D		W Hex. Flat	Wa Hex. Flat	M		I		N		L	
	mm	mm	mm	mm	mm	mm	mm	mm	mm	mm	mm	mm	mm	mm
762L _ 10 mm Dielectric	10	7.1	22	18	65.85	17.2	84.85	100.3						
762L _ 12 mm Dielectric	12	7.1	22	22	61.70	22.8	87.10	107.3						

TUBE (INCH) TO TUBE (INCH)

Ordering Information	A Tube O.D.		D		W Hex. Flat	Wa Hex. Flat	M		I		N		L	
	inch	mm	inch	mm	inch	inch	mm	inch	mm	inch	mm	inch	mm	
762L _ 1/8 Dielectric	1/8	3.17	.09	2.28	13/16	1/2	2.56	65.10	.50	12.7	3.07	77.94	3.59	9.11
762L _ 1/4 Dielectric	1/4	6.35	.19	4.80	13/16	1/2	2.57	65.30	.60	15.2	3.19	81.02	3.77	95.8
762L _ 3/8 Dielectric	3/8	9.52	.28	7.11	13/16	5/8	2.59	65.80	.66	16.8	3.34	84.87	3.92	99.6
762L _ 1/2 Dielectric	1/2	12.70	.28	7.11	13/16	13/16	2.37	60.20	.90	22.9	3.37	85.68	4.17	106.0

"D" - Dimension is minimum opening. Dimensions are for reference only, and are subject to change without notice.

TUBE (INCH) TO MALE NPT THREAD

Ordering Information	A Tube O.D.		T (NPT)	D		W Hex. Flat	Wa Hex. Flat	I		N		L	
	inch	mm	inch	inch	mm	inch	inch	inch	mm	inch	mm	inch	mm
768L_3/8 X 1/4 Dielectric	3/8	9.52	1/4	.28	7.11	7/8	5/8	.66	16.8	3.44	87.4	3.73	94.7

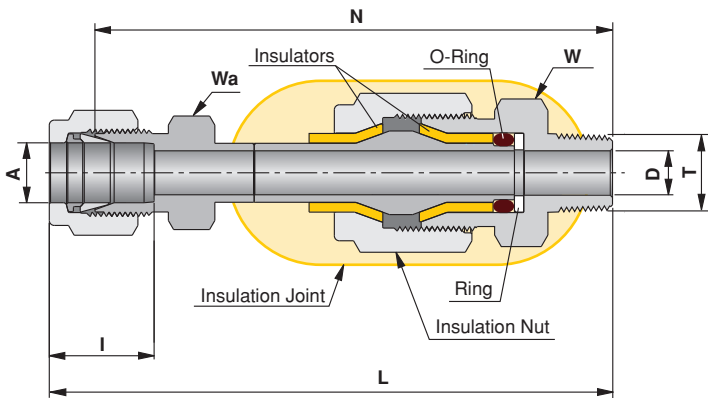

Assembly Instructions for Dielectric Fittings

1. Hold Hex A (Back-Up) and tighten nut A according to Let-Lok assembly instructions (see Let-Lok catalog for more information).
2. Hold Hex B (Back-Up) and tighten nut B according to the Let-Lok assembly instructions.

CAUTION: DO NOT LOOSEN the INSULATION NUT and DO NOT USE IT as a BACK UP HEX.

Notes:

1. If end connection is Taper Pipe Thread - apply pipe sealant on thread and use hex A or B as wrenching or as Backup hex.
2. For additional types of end connection, please contact your authorized Ham-Let representative.

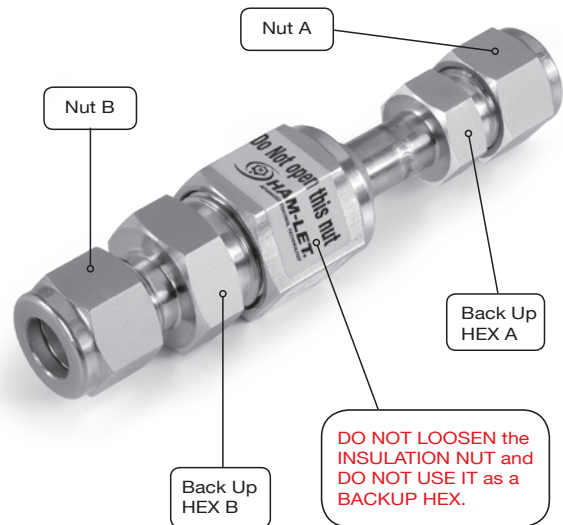

Warning! For Your Safety

The system designer and user have the sole responsibility to select products suitable for their special application requirements and to ensure the proper installation, operation and maintenance of the product. Please consider application details, material compatibility and product ratings when making your selection. Improper selection or use of products can cause property damage or personal injury.

"D" - Dimension is minimum opening. Dimensions are for reference only, and are subject to change without notice.



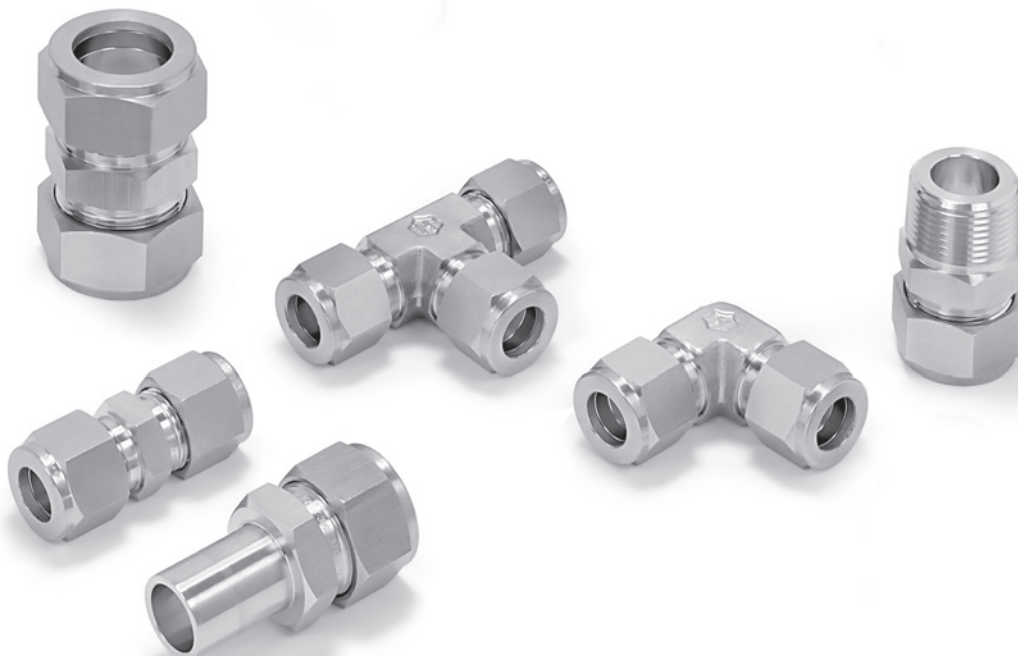





HAM-LET MONEL® NICKEL-COPPER ALLOY 400/R-405 CONNECTORS



Monel nickel-copper alloy 400 is a solid-solution alloy that can be hardened only by cold working. It has high strength and toughness over a wide temperature range and excellent resistance to many corrosive environments. Alloy 400 is widely used in many fields, especially marine and chemical processing.

MONEL MATERIAL STD

Barstock	Forging
ASTM B 164	ASTM B 564

760LB - Back Ferrule*			760LF - Front Ferrule*			761L - Nut			762L - Union		
	Ordering info.	Tube O.D.		Ordering info.	Tube O.D.		Ordering info.	Tube O.D.		Ordering info.	Tube O.D.
	760LB M 1/4	1/4		760LF M 1/4	1/4		761L M 1/4	1/4		762L M 1/4	1/4
	760LB M 3/8	3/8		760LF M 3/8	3/8		761L M 3/8	3/8		762L M 3/8	3/8
	760LB M 1/2	1/2		760LF M 1/2	1/2		761L M 1/2	1/2		762L M 1/2	1/2
764L - Union Tee			765L - Union Elbow			767LP - Port Connector			7108L - Cap		
	Ordering info.	Tube O.D.		Ordering info.	Tube O.D.		Ordering info.	Tube O.D.		Ordering info.	Tube O.D.
	764L M 1/4	1/4		765L M 1/4	1/4		767LP M 1/4	1/4		7108L M 1/4	1/4
	764L M 3/8	3/8		765L M 3/8	3/8		767LP M 3/8	3/8		7108L M 3/8	3/8
	764L M 1/2	1/2		765L M 1/2	1/2		767LP M 1/2	1/2		7108L M 1/2	1/2

* All LET-LOK ferrules are available as sets.

Dimensions are for reference only, and are subject to change without notice.

ALLOY 400/R-405

774L - Bulkhead union

	Ordering info.	Tube O.D.
	774L M 1/4	1/4
	774L M 3/8	3/8

7121L - Plug

	Ordering info.	Tube O.D.
	7121L M 1/4	1/4
	7121L M 3/8	3/8
	7121L M 1/2	1/2

767LT - Reducer

	Ordering info.	Tube O.D.	Tube O.D.
	767LT M 1/4 x 1/4	1/4	1/4
	767LT M 1/4 x 3/8	1/4	3/8
	767LT M 1/4 x 1/2	1/4	1/2
	767LT M 3/8 x 1/4	3/8	1/4
	767LT M 3/8 x 3/8	3/8	3/8
	767LT M 3/8 x 1/2	3/8	1/2
	767LT M 1/2 x 1/4	1/2	1/4
	767LT M 1/2 x 3/8	1/2	3/8
	767LT M 1/2 x 1/2	1/2	1/2

769L - Male Elbow

	Ordering info.	Tube O.D.	Male pipe size
	769L M 1/4 x 1/4	1/4	1/4
	769L M 3/8 x 1/4	3/8	1/4
	769L M 1/2 x 1/2	1/2	1/2

766L - Female Connector

	Ordering info.	Tube O.D.	Female pipe size
	766L M 1/4 x 1/4	1/4	1/4
	766L M 3/8 x 1/4	3/8	1/4

739LF - Female Adapter

	Ordering info.	Tube O.D.	Female pipe size
	739LF M 1/4 x 1/8	1/4	1/8
	739LF M 1/4 x 1/4	1/4	1/4
	739LF M 1/4 x 1/2	1/4	1/2
	739LF M 3/8 x 1/4	3/8	1/4
	739LF M 3/8 x 1/2	3/8	1/2
	739LF M 1/2 x 1/4	1/2	1/4
	739LF M 1/2 x 1/2	1/2	1/2

768L - Male Connector

	Ordering info.	Tube O.D.	Male pipe size
	768L M 1/4 x 1/8	1/4	1/8
	768L M 1/4 x 1/4	1/4	1/4
	768L M 1/4 x 3/8	1/4	3/8
	768L M 1/4 x 1/2	1/4	1/2
	768L M 3/8 x 1/4	3/8	1/4
	768L M 3/8 x 3/8	3/8	3/8
	768L M 3/8 x 1/2	3/8	1/2
	768L M 1/2 x 1/4	1/2	1/4
	768L M 1/2 x 3/8	1/2	3/8
	768L M 1/2 x 1/2	1/2	1/2
	768L M 1/2 x 3/4	1/2	3/4

739LM - Male Adapter

	Ordering info.	Tube O.D.	Male pipe size
	739LM M 1/4 x 1/8	1/4	1/8
	739LM M 1/4 x 1/4	1/4	1/4
	739LM M 1/4 x 1/2	1/4	1/2
	739LM M 3/8 x 1/4	3/8	1/4
	739LM M 3/8 x 1/2	3/8	1/2
	739LM M 1/2 x 1/4	1/2	1/4
	739LM M 1/2 x 1/2	1/2	1/2

LET-LOK TUBING DATA FOR ALLOY 400

Alloy 400 tubes should be ordered according to ASTM B-165. Hydraulic tubing is suitable for flaring and bending.

Tubing should be seamless and annealed. Hardness: 75 HRB maximum.

Tube O.D. inch	0.028	0.035	0.049	0.065
1/4	3700	4800	7000	9500
3/8		3100	4400	6100
1/2		2300	3200	4400

Allowable working pressure in psig at -20° to 100°F (-28° to 37°C)

GAS APPLICATION TUBING

Tube O.D.	Min. Nominal wall thickness
1/2"	.035"

Dimensions are for reference only, and are subject to change without notice.

HAM-LET HASTELLOY® ALLOY C-276 CONNECTORS

In aggressive/corrosive service, when nothing else works, many industries have traditionally turned to **HASTELLOY® C-276** alloy. Many years of outstanding performance in a variety of industrial applications have confirmed the advantages of using this alloy.

Excellent Resistance to Corrosion

HASTELLOY® C-276 alloy is a nickel-molybdenum-chromium wrought alloy that is generally considered a versatile corrosion-resistant alloy.

C-276 alloy has excellent resistance to localized corrosion and to both oxidizing and reducing media. Because of its versatility, C-276 alloy can be used where “upset” conditions are likely to occur in multipurpose plants.

HASTELLOY® C-276 alloy has excellent resistance to a wide variety of chemical process environments, including strong oxidizers such as ferric and cupric chlorides, hot contaminated media (organic and inorganic), chlorine,

formic and acetic acids, acetic anhydride, and seawater and brine solutions. It is used in flue gas desulfurization systems because of its excellent resistance to sulfur compounds and chloride ions encountered in most scrubbers. **C-276** alloy has excellent resistance to pitting and to stress-corrosion cracking. It is also one of the few materials that withstands the corrosive effects of wet chlorine gas, hypochlorite and chlorine dioxide.

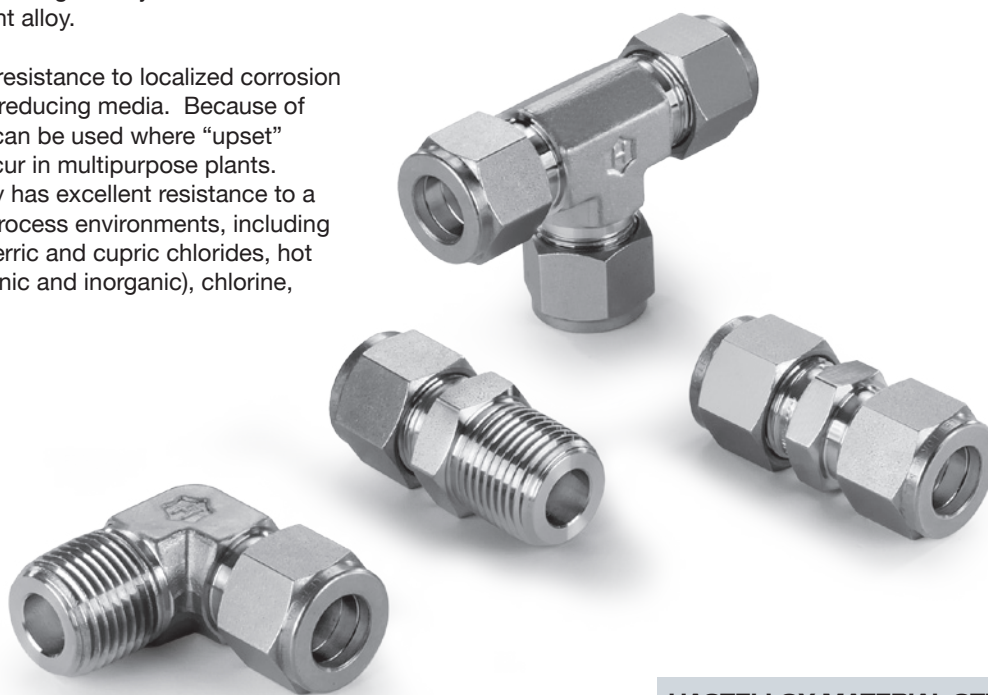

HASTELLOY MATERIAL STD

Barstock	Forging
ASTM B574	ASTM B564

760LB - Back Ferrule*		
	Ordering info.	Tube O.D.
	760LB HC 1/4	1/4
	760LB HC 3/8	3/8
	760LB HC 1/2	1/2

760LF - Front Ferrule*		
	Ordering info.	Tube O.D.
	760LF HC 1/4	1/4
	760LF HC 3/8	3/8
	760LF HC 1/2	1/2

761L - Nut		
	Ordering info.	Tube O.D.
	761L HC 1/4	1/4
	761L HC 3/8	3/8
	761L HC 1/2	1/2

762L - Union		
	Ordering info.	Tube O.D.
	762L HC 1/4	1/4
	762L HC 3/8	3/8
	762L HC 1/2	1/2

764L - Union Tee		
	Ordering info.	Tube O.D.
	764L HC 1/4	1/4
	764L HC 3/8	3/8
	764L HC 1/2	1/2

765L - Union Elbow		
	Ordering info.	Tube O.D.
	765L HC 1/4	1/4
	765L HC 3/8	3/8
	765L HC 1/2	1/2



767LP - Port Connector		
	Ordering info.	Tube O.D.
	767LP HC 1/4	1/4
	767LP HC 3/8	3/8
	767LP HC 1/2	1/2



7108L - Cap		
	Ordering info.	Tube O.D.
	7108L HC 1/4	1/4
	7108L HC 3/8	3/8
	7108L HC 1/2	1/2



* All LET-LOK ferrules are available as sets.

Dimensions are for reference only, and are subject to change without notice.

ALLOY C-276

774L - Bulkhead union			7121L - Plug			767LT - Reducer			
	Ordering info.	Tube O.D.		Ordering info.	Tube O.D.		Ordering info.	Tube O.D.	Tube O.D.
	774L HC 1/4	1/4		7121L HC 1/4	1/4		767LT HC 1/4 x 1/4	1/4	1/4
	774L HC 3/8	3/8		7121L HC 3/8	3/8		767LT HC 1/4 x 3/8	1/4	3/8
			7121L HC 1/2	1/2	767LT HC 1/4 x 1/2		1/4	1/2	
					767LT HC 3/8 x 1/4		3/8	1/4	
					767LT HC 3/8 x 3/8		3/8	3/8	
					767LT HC 3/8 x 1/2		3/8	1/2	
					767LT HC 1/2 x 1/4		1/2	1/4	
					767LT HC 1/2 x 3/8		1/2	3/8	
					767LT HC 1/2 x 1/2	1/2	1/2		

769L - Male Elbow				766L - Female Connector			
	Ordering info.	Tube O.D.	Male pipe size		Ordering info.	Tube O.D.	Female pipe size
	769L HC 1/4 x 1/4	1/4	1/4		766L HC 1/4 x 1/4	1/4	1/4
	769L HC 3/8 x 1/4	3/8	1/4		766L HC 3/8 x 1/4	3/8	1/4
	769L HC 1/2 x 1/2	1/2	1/2				

739LF - Female Adapter				768L - Male Connector			
	Ordering info.	Tube O.D.	Female pipe size		Ordering info.	Tube O.D.	Male pipe size
	739LF HC 1/4 x 1/8	1/4	1/8		768L HC 1/4 x 1/8	1/4	1/8
	739LF HC 1/4 x 1/4	1/4	1/4		768L HC 1/4 x 1/4	1/4	1/4
	739LF HC 1/4 x 1/2	1/4	1/2		768L HC 1/4 x 3/8	1/4	3/8
	739LF HC 3/8 x 1/4	3/8	1/4		768L HC 1/4 x 1/2	1/4	1/2
	739LF HC 3/8 x 1/2	3/8	1/2		768L HC 3/8 x 1/4	3/8	1/4
	739LF HC 1/2 x 1/4	1/2	1/4		768L HC 3/8 x 3/8	3/8	3/8
	739LF HC 1/2 x 1/2	1/2	1/2		768L HC 3/8 x 1/2	3/8	1/2
			768L HC 1/2 x 1/4		1/2	1/4	
			768L HC 1/2 x 3/8		1/2	3/8	
			768L HC 1/2 x 1/2		1/2	1/2	
			768L HC 1/2 x 3/4		1/2	3/4	

739LM - Male Adapter			
	Ordering info.	Tube O.D.	Male pipe size
	739LM HC 1/4 x 1/8	1/4	1/8
	739LM HC 1/4 x 1/4	1/4	1/4
	739LM HC 1/4 x 1/2	1/4	1/2
	739LM HC 3/8 x 1/4	3/8	1/4
	739LM HC 3/8 x 1/2	3/8	1/2
	739LM HC 1/2 x 1/4	1/2	1/4
	739LM HC 1/2 x 1/2	1/2	1/2

LET-LOK TUBING DATA FOR ALLOY C-276					
Alloy C-276 tubes should be ordered according to ASTM B-622. Hydraulic tubing is suitable for flaring and bending. Tubing should be seamless and annealed. Hardness: 100 HRB maximum.	Tube O.D. inch	0.035	0.049	0.065	
	1/4	5100	7500	10200	
	3/8	3300	4800	6500	
	1/2	2600	3700	5100	
GAS APPLICATION TUBING					
	Tube O.D.	Min. Nominal wall thickness			
	1/2"	.035"			

Dimensions are for reference only, and are subject to change without notice.

ACCESSORIES

G-RAPID PLUS LOW FRICTION PASTE

INSTALLATION INSTRUCTIONS FOR LET-LOK® FITTINGS 38mm–50mm 1 1/4”–2”



1. Close the nut and ferrules on the tube with a hydraulic tool.
2. Open and release from the tool.
3. Apply the G-Rapid paste on areas A and B.
4. Tighten the nut on body 1/2 a turn with a wrench

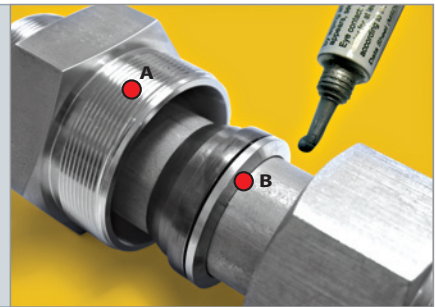

To order:
use part No. 3900753

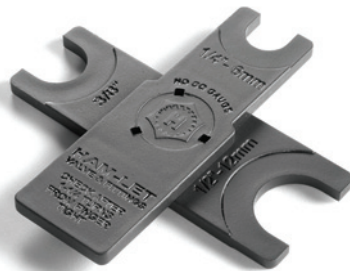

GOLDEN GAUGE

SIZE:

GAUGE	
PART NO.	AVAILABLE ONLY IN
3900098	1/4" (6mm), 3/8", 1/2" (12mm)

HIGH SAFETY SIDE



HIGH SAFETY

In applications where severe conditions and high pressure exist, we recommend the following installation procedures:

1. Check that the nut is finger tight.
2. Insert the tube (up to the shoulder).
3. Rotate the nut with a wrench until the tube does not rotate freely.
4. Mark position of the nut.
5. Rotate the nut 1-1/4 turns.

This method ensures that even if the tube O.D. is at the minimum tolerance, the ferrules will be in contact with the tube for the full 1-1/4 rotation.

ADDITIONAL SIZES:

GOLDEN GAUGE	
PART NO.	LET-LOK SIZE
3901508	Golden Gauge 1/16"
3901509	Golden Gauge 1/8"–2–3 mm
3901510	Golden Gauge 3/16"– 4 mm
3901513	Golden Gauge 5/16"– 8 mm
3901511	Golden Gauge 10 mm
3901247	Golden Gauge 5/8"–14–15–16 mm
3901246	Golden Gauge 3/4"–18 mm
3901512	Golden Gauge 7/8"–20–22 mm
3901245	Golden Gauge 1"–25 mm

Dimensions are for reference only, and are subject to change without notice.



STAINLESS STEEL TUBE CUTTER

Ordering Information	Capacity	
	inch	mm
Tube Cutter	3/16-1	5-25
Replacement Wheel	3/16-1	5-25



REAMERS, DEBURRING TOOLS

Ordering Information	Capacity
In.Out.Reamer 1/4"-1 1/4"	1/4" (5mm) through 1 1/4" (36mm)
In.Out.Reamer 1/2"-2"	1/2" (12mm) through 2" (54mm)



LEVER TUBE BENDERS

Ordering Information	Capacity	
	Tube Size	Bend Radius
Lever Bender 3/16	3/16"	5/8"
Lever Bender 1/4	1/4"	5/8"
Lever Bender 5/16	5/16"	15/16"
Lever Bender 3/8	3/8"	15/16"
Lever Bender 1/2	1/2"	1 1/2"
Lever Bender 6	6mm	16mm
Lever Bender 8	8mm	24mm
Lever Bender 10	10mm	24mm
Lever Bender 12	12mm	38mm



HYDRAULIC PRE-ASSEMBLY TOOL

Ordering Information	Description	
HPAT- Large	Full large size tool - 1", 1 1/4", 1 1/2"	
HPAH - 1"	1"	Pre Assembly Head
HPAH - 1 1/4"	1 1/4"	
HPAH - 1 1/2"	1 1/2"	



TUBE HOLDERS

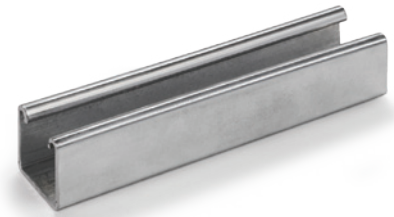
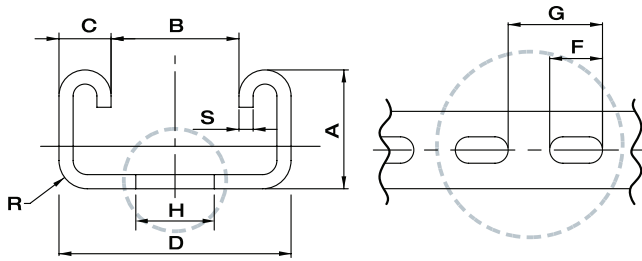

PERFORATED STAINLESS STEEL TUBE HOLDER SUPPORT

HL / PN	A, mm	B, mm	C, mm	D, mm	L, m	S, mm	R, mm	F, mm	G, mm	H, mm
P-L-G	41.0	22.6	9.2	41.0	6.0	2.5	5.0	28.0	50.0	14.0
P-S-G	21.0	22.6	9.2	41.0	6.0	2.5	5.0	28.0	50.0	14.0
P-L-Z	41.0	22.6	9.2	41.0	6.0	2.5	5.0	28.0	50.0	14.0
P-S-Z	21.0	22.6	9.2	41.0	6.0	2.5	5.0	28.0	50.0	14.0

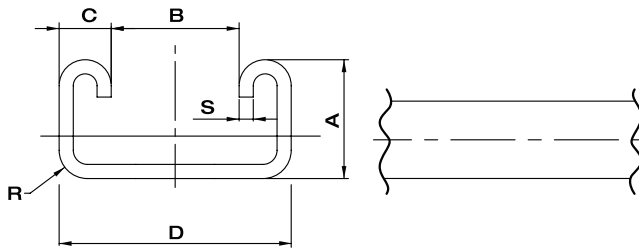

BLANK STAINLESS STEEL TUBE HOLDER SUPPORT

HL / PN	A, mm	B, mm	C, mm	D, mm	L, m	S, mm	R, mm
B-L-G	41.0	22.6	9.2	41.0	6.0	2.5	5.0
B-S-G	21.0	22.6	9.2	41.0	6.0	2.5	5.0
B-L-Z	41.0	22.6	9.2	41.0	6.0	2.5	5.0
B-S-Z	21.0	22.6	9.2	41.0	6.0	2.5	5.0

ORDERING INFORMATION

Perforation

P = Perforated
B = Blank

Size

S = Small
L = Large

Finish Type

Z = Zink Coating Yellow
G = Hot dip galvanized

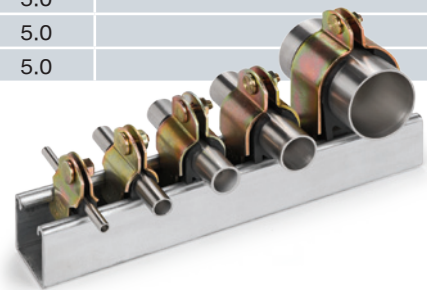

CLAMPED TUBE HOLDERS

HL / PN	A, mm	B, mm	C, mm	D, mm
CTH-1/4	1/4	5.7	29.2	18.2
CTH-3/8	3/8	7.3	32.2	23.0
CTH-1/2	1/2	7.8	36.6	23.7
CTH-5/8	5/8	22.6	41.7	25.0
CTH-3/4	3/4	13.8	48.3	32.7
CTH-7/8	7/8	22.6	51.2	34.0
CTH-1	1	16.8	53.8	40.8
CTH-1 1/8	1-1/8	22.6	59.4	40.9
CTH-1 5/8	1-5/8	22.6	71.8	58.3
CTH- 2	2	30.4	82.0	64.1

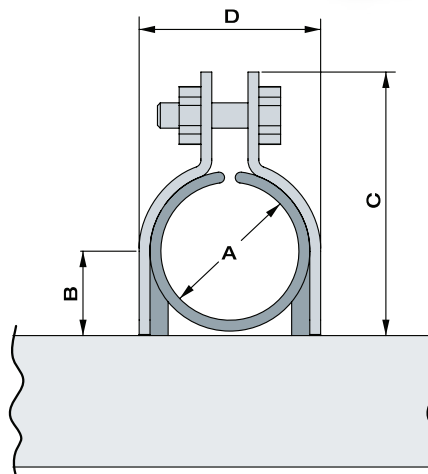

STOP COLLAR

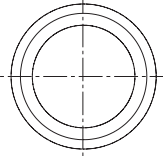
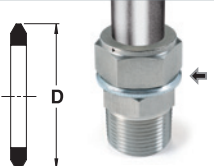
LET-LOK			D	Assembly Instructions - Stop Collar	
inch	inch	mm			
1/4	.69	17.5	<ol style="list-style-type: none"> 1. Remove the nut and ferrules from the fitting. 2. Insert the stop collar. 3. Assemble the nut and ferrules until finger tight. 4. Make up the fitting until the stop collar no longer rotates (feel with finger). At this stage it is guaranteed that the fitting is made up correctly. 		
3/8	.84	20.6			
1/2	1.10	27.0			
3/4	1.31	33.3			
1	1.68	42.7			

ORDERING INFORMATION FOR ASSEMBLED STOP COLLAR (WITH FITTING)

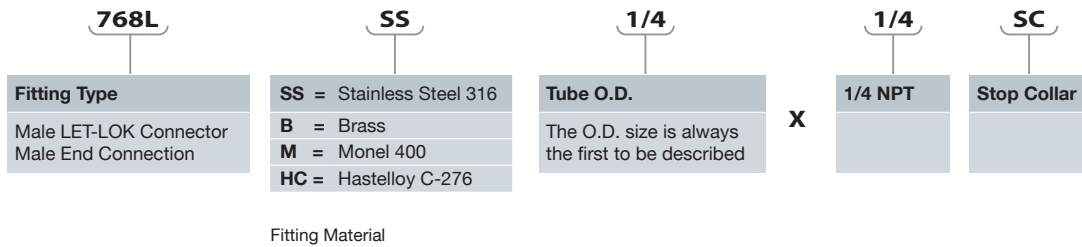

HOW TO ORDER STOP COLLAR ONLY

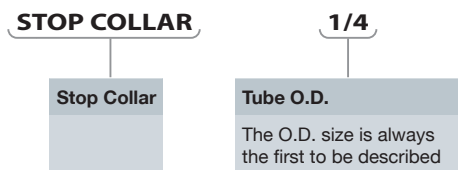

Dimensions are for reference only, and are subject to change without notice.