

AQUApipe M-Profile Stainless Steel Pipe System Specification



Contents

1. General	-----	03
1.1 Summary		
1.2 Performance Parameters		
1.3 Engineering Standards		
2. Products	-----	04
2.1 Stainless Steel Pipe		
2.2 Stainless Steel Fittings		
2.3 Tooling		
2.4 Seal Options		
3. Preparation	-----	06
3.1 Examination		
3.2 Preparation		
4. Installation	-----	06
4.1 Pipe Installation		
4.2 Hanger and Support Installation		
4.3 Installation Notices		
4.4 Field Quality Control		
5. Products Installation Instructions	-----	08
5.1 AQUApine Stainless Steel 18mm to 54mm		
5.2 AQUApine Stainless Steel 76.1mm to 108mm		
5.3 AQUApine Stainless Steel DN150 to DN250		
6. Dimensional Information	-----	11
6.1 AQUApine Stainless Steel 18mm to 108mm		
6.2 AQUApine Stainless Steel DN150 to DN250		
7. Limited Warranty	-----	24



Part 1 - General

1.1 Summary

- A. AQUApipe is a complete stainless-steel pipe and fitting system designed to convey fluids and gases used in a variety of Multiple applications:
- closed water circuits -30 °C to +110 °C
 - closed refrigerating and cooling circuits
 - mineral oil, vegetable oil, light fuel oil
 - compressed air systems class 1-10
 - inert gases (non-toxic/non-explosive)
 - vacuum up to 100 mbar absolute pressure
 - demineralised water, Osmosis water(closed circuits)
 - solar installations up to +100 °C
 - extinguishing water lines dry
 - district heating in domestic connection lines
- B. Applications NOT covered:
- Ø Drinking water installations
 - Ø Gas installations as per TRGI
 - Ø Sprinkler systems as per VdS
 - Ø Water fire main wet, wet/dry
 - Ø Open water circulation systems
- C. Permanent press technology is used on pipe diameters 18mm to 108mm.
- D. Modular and reusable clamshell technology is used on pipe diameters DN150 to DN250.

1.2 Performance Parameters

- A. This specification encompasses piping and fittings for compressed gas and fluid systems operating at an industrial vacuum of 1 mbar absolute to 16 bar (in diameters 18mm to DN150) and 13 bar (in diameters DN200 to DN250, DN250 pressure rating is only for fluid systems).
Operating temperature levels are dependent on the seal material:
NBR, -20°C to +100°C;
EPDM, -20°C to +120°C;
FKM, -20°C to +200°C.

1.3 Engineering Standards

- A. AISI 304 - DIN EN 1.4301, AISI 316L- DIN EN 1.4404, EN 10217-7, EN 10312 pipe manufacturing standard.
- B. EC Conformity to 2014/68/UE Pressure Equipment Directive.
- C. NPT (ANSI B 1.20.1) Thread Type.
- D. ANSI Class 150 Flange Type.
- E. ISO EN1092-1 Flange Type.
- F. ISO 228-1(BSPP) and ISO 7-1(BSPT) Thread Dimensions.
- G. ISO 8573-1 Class 1.1.1 for compressed air quality.
- H. UL94HB.
- I. FDA CFR 21, GRAS, U.S. Food and Drugs Regulation.
- J. EC Regulation 1935/2004 on material intended to come in contact with food.
- K. NSF 61, NSF 372.

Part 2 - Products

2.1 Stainless Steel Pipe

A. AQUApipe stainless steel pipe is offered in 304 or 316 stainless steel to compliment the AQUApipe fittings and offer a complete solution.

B. Pipe Dimensions:

Normal and Outer Diameter	Wall Thickness	Length	Qty/Bale
18 mm	0.8mm	5.8m	20
22 mm	1.0mm	5.8m	15
28 mm	1.0mm	5.8m	10
35 mm	1.2mm	5.8m	5
42 mm	1.2mm	5.8m	5
54 mm	1.2mm	5.8m	5
76.1 mm	1.5mm	5.8m	2
88.9 mm	1.5mm	5.8m	2
φ108 mm	1.5mm	5.8m	1
DN150 (OD 159 mm)	2.0mm	5.8m	1
DN200 (OD 219 mm)	2.5mm	5.8m	1
DN250 (OD 273 mm)	3.0mm	5.8m	1

2.2 Stainless Steel Fittings

A.  AQUApipe fittings 18mm to 108mm shall be 304 or 316 permanent press joints with interchangeable captivated seals. Configurations include elbows, tees, couplings, ball valves, reducing tees, threaded adapters, reducing couplings, flanges, butterfly valves, caps, and clips/hangers. AQUApipe fittings have integrated blue plastic tabs for easy complete press identification. AQUApipe is designed to full compatibility with stainless steel pipes from the market.

B.  AQUApipe fittings DN150 to DN250 shall be 304 or 316 groove and clamshell joints with interchangeable seals. Configurations include elbows, tees, couplings, ball valves, reducing tees, threaded adapters, reducing couplings, flanges, butterfly valves, caps, and clips/hangers. AQUApipe fittings are designed only to be used with AQUApipe stainless steel pipe.

C. Consult the AQUApipe catalog of products for the complete configuration offering, part numbers, and dimensions.





2.3 Tooling

- A. AQUApipe fittings 18mm to 108mm will need a portable battery powered press tool and AQUApipe jaws sets to permanently press AQUApipe fittings onto pipe. Other compatible pressing units and M-Profile jaws set can be used to permanently press the fittings.
- B. AQUApipe fittings DN150 to DN250 will utilize either an electric, or portable hand-operated lugging machine to apply convex grooves to cut ends of pipe.

2.4 Seal Options

- A. NBR – Operating temperature -20°C to +100°C. NBR also known as Nitrile, is Nitrile Butadiene Rubber, a specialty purpose compound used where resistance to petroleum-based additives are required. NBR possess excellent physical strength and retention properties after long term exposure to heat, oil, chemicals, and compressed air. NBR is used for applications of compressed air, mixed, and manufactured gases. NBR's versatility has resulted in wide use in automotive, industrial, and assorted high-performance applications.
- B. EPDM – Operating temperature -20°C to +120°C. EPDM, or ethylene-propylenediene rubber, is a synthetically manufactured and peroxidically cured all-purpose elastomer. EPDM sealing elements possess excellent resistance to aging, sunlight, weathering, ozone, environmental influences, alkalis, and most alkaline solutions along with chemicals used in a broad range of applications including ketones.
- C. FKM/ FPM – Operating temperature -20°C to +200°C. FKM or FPM also known as Viton, is a fluoroelastomer, or synthetic fluorinated rubber specialty purpose elastomer. FKM/ FPM sealing elements possess excellent resistance to chemicals, higher temperatures, sunlight, weathering, ozone, environmental influences, oils, and petroleum-based additives. FKM/ FPM's resistance to higher temperatures and aggressive chemicals make it ideal for extreme industrial applications.

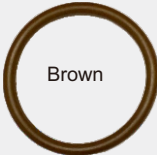
Sealing	Description	Color	Working Temperature	Main Applicable Medium
NBR	Nitrile Butadiene Rubber	 Yellow	-20°C to 100°C -4°F to 212°F	Hydraulic Oils, Inert Gases, Compressed Air, Lubricants.
EPDM <i>*in option</i>	Ethylene Propylene Diene Monomer	 Black	-20°C to 120°C -4°F to 248°F	Chilled/Cooling Water; Waste Waters; Hydronic Heating; Low Pressue Steam.
FKM/FPM <i>*in option</i>	Viton Fluoroelastomer	 Brown	-20°C to 200°C -4°F to 392°F	High Temp. Steam & Gas, Solar, Heating, Compressed Air, Acid Solutions, Chemicals, Inert Gases.



Part 3 - Preparation

3.1 Examination

- A. The installer shall examine the stainless steel pipe and fittings for defects and cracks. There shall be no defects of the pipe or fittings. Any damaged pipe or fittings shall be rejected.

3.1 Preparation

- A. Stainless steel pipe shall be cut with a wheeled pipe cutter or approved stainless steel pipe cutting tool. The pipe shall be cut square to permit proper joining with the fittings.
- B. Remove scale, dirt, and debris from inside and outside of pipe and fittings before assembly. The pipe end shall be wiped clean and dry. The burrs of the pipe shall be reamed with a deburring or reaming tool.

Part 4 - Installation

4.1 Pipe Installation

- A. All stainless piping to be installed in strict accordance with AQUApipe installation instructions and specifications.
- B. Pressure rating of non-AQUApipe components: Components installed to AQUApipe shall have a pressure rating equal to or greater than the system operating pressure.
- C. Press Connections: The pipe shall be fully inserted into fitting body. The joints shall be pressed by the tool provided by the manufacturer or tools and dies for M-profile from market.
- D. Threaded joints shall have joint compound or Teflon tape applied to the male threads only. Tighten joint with wrench as required.
- E. Drawing plans, schematics, and diagrams indicate general location and arrangement of stainless steel piping. Indicated locations and arrangements were used to size pipe and calculate friction loss, expansion, sizing, and other design considerations. Install piping as indicated unless deviations to layout are approved.
- F. Install piping indicated to be exposed and piping in equipment rooms and service areas at right angles or parallel to building walls.
- G. Install piping adjacent to equipment and machines to allow service and maintenance.
- H. Install piping to permit valve servicing.
- I. Install piping free of sags and bends.
- J. Install sleeves for piping penetrations of walls, ceilings, and floors.
- K. Install escutcheons for piping penetrations of walls, ceilings, and floors.
- L. Provide fire caulk around all penetrations thru fire separations in accordance with the building code. Do not penetrate fire walls without specific instructions from the engineer. Submit UL listing for all fire-proofing materials.
- M. Backfill material shall not include any ashes, refuse, cinders, stones, boulders, or other materials which could damage or break the pipe or cause corrosive action in any trench or excavation in which pipe is installed.

4.2 Hanger And Support Installation

- A. Horizontal and vertical AQUApipe piping shall be supported every 2.5m by AQUApipe fixing clips or equals. Hangers shall be either stainless steel, nylon, or vinyl coated to prevent galvanic corrosion between the pipe and supporting member. Hanger rods to be solid with only enough thread for the connection ends. Install hangers in accordance with local codes and requirements.

- B. Vertical stainless steel pipe shall be supported at each floor or at 10 foot / 3m intervals.
- C. Stainless steel pipe systems shall have pipe markers in accordance with the requirements of local codes and requirements.
- D. Expansion and contraction of the system shall be calculated prior to installation. The system designer and installer should calculate the elongation or retraction of each line.

4.3 Installation Notices

- A. Avoid direct contact between stainless steel pipe and carbon steel components. If it is unavoidable, rubber pad or wood block shall be used to prevent galvanic corrosion.
- B. Outdoor stainless steel pipes shall not be placed under the protective fence, steel table, etc., and shall not be connected with other metal pipe fittings as far as possible to avoid galvanic corrosion. If it is unavoidable, insulation should be taken to prevent corrosion.
- C. Avoid chemical corrosion on the surface of stainless steel pipe caused by oxalic acid liquid, which is normally used for cleaning the internal and external wall tiles.
- D. Avoid direct contact of stainless steel pipe with cement, mortar and mixing concrete to prevent chloride corrosion. If it is unavoidable, plastic film or anti-corrosion tape can be wrapped on the outer wall of the pipe for protection, or plastic coated thin-wall stainless steel pipe can be selected.
- E. Stainless steel pipes shall not be laid in the flue, air duct, drainage ditch, lift well, LV/HV silo, they shall not pass through the urinal and the power distribution room, etc.
- F. When stainless steel pipes are concealed for underground application, anti-corrosion measures shall be taken, such as wrapping anti-corrosion tape or using plastic coated stainless steel pipes.

4.4 Field Quality Control

- A. Only tap water can be used during pressure test. It is forbidden to use groundwater, river water and other water quality that has not been tested to be qualified for pressure test.
- B. After the pressure test, the water in the pipeline shall be discharged completely.
- C. For drinking water pipeline filled with potassium permanganate for disinfection should not keep more than 24 hours, and after draining completely, it should be rinsed with drinking water.
- D. The sodium hypochlorite liquid used for cleaning the pipeline shall be washed immediately, and shall not be stored in the pipe to avoid corrosion.
- E. If the pipeline is idle for a long time after pressure test or a longtime shutdown occurs, the residual water in the pipeline shall be washed every 15 days and discharged completely.
- F. The chloride content in tap water/drinking water normally is at level of 1ppm more or less based on WHO guidelines, it's safe for health and will not create damage corrosion to stainless pipe, while cooling water in industry application will create chloride concentration during water evaporating process, the water treatment shall take control to make sure chloride content is less than 200ppm.
- G. Stainless steel pipe is not allowed to transport water with excessive fluorine, chlorine, bromine and iodide content. For example: polluted rivers, lakes, groundwater and tap water stored in reservoirs for a long time.

Part 5 - Product Installation Instructions

5.1 AQUApipe Stainless Steel 18mm to 54mm

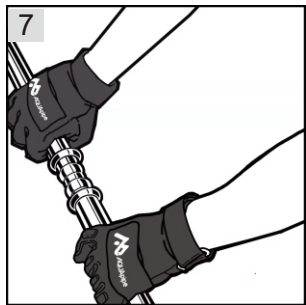
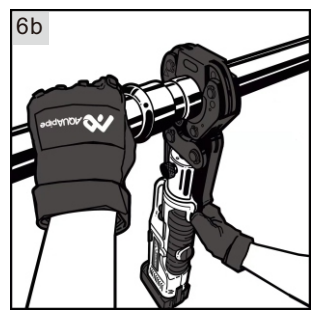
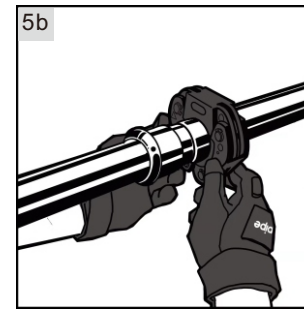
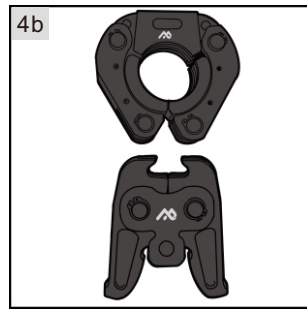
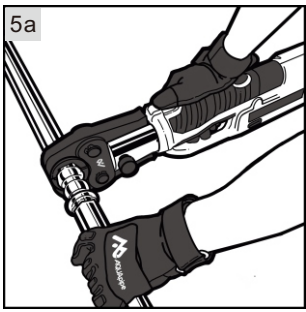
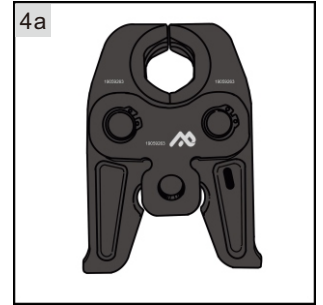
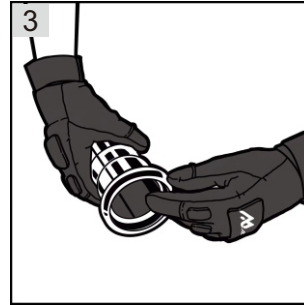
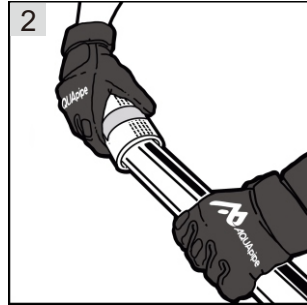
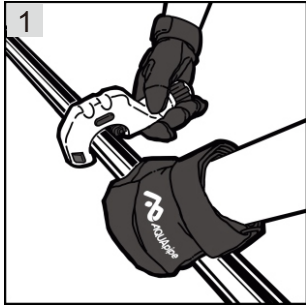

1. Use pipe cutter to cut the pipe at right angles.

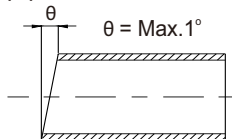

2. Deburr inside and outside of pipe.

3. Check seal for correct fit. Do not use oils and lubricants.

4a. AQUApipe stainless steel fittings 18mm to 35mm connections can be performed with AQUApress jaws, as well as jaws for M-profile from market.

5a. Open the AQUApipe jaw and place at right angles on the fittings. Start pressing process and hold the trigger until the jaw have engaged the fittings.

4b. AQUApipe stainless steel fittings 42mm to 54mm connections can be performed with AQUApipe press jaw ring and scissor, as well as its for M-profile from the market.

5b. Open the AQUApipe jaw ring and place at the right angles on the fittings.

6b. Place scissor onto AQUApipe jaw ring and start pressing process; hold the trigger until the scissor has engaged the AQUApipe jaw ring.

7. Remove scissor from AQUApipe jaw ring and then remove AQUApipe jaw ring from fitting, remove identify plastic blue film to indicate press has been completed.

Product Installation Instructions

5.2 AQUApipe Stainless Steel 76.1mm to 108mm

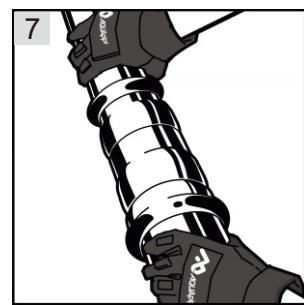
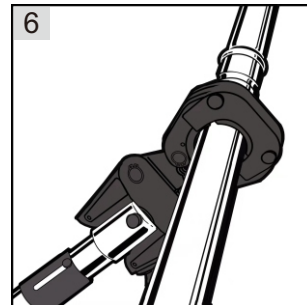
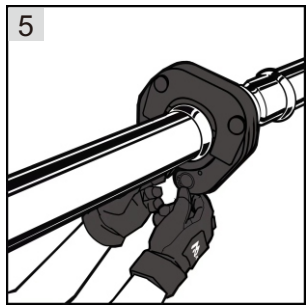
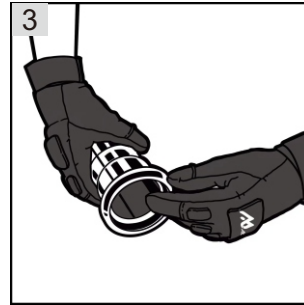
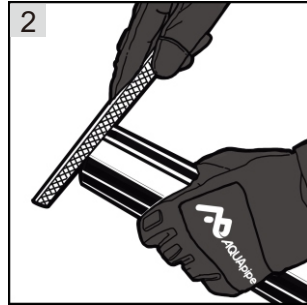
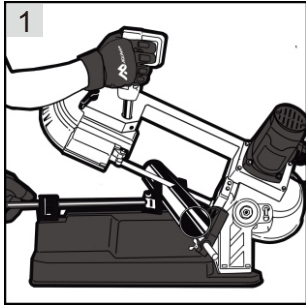

1. Use pipe cutter to cut the pipe at right angles.

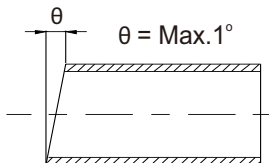

2. Deburr inside and outside of pipe.
3. Check seal for correct fit. Do not use oils and lubricants.
4. AQUApipe stainless steel fittings 76.1mm to 108mm connections must be performed with M-Profile press jaw ring and scissor from the market.

5. Open the jaw and place at right angles on the fittings.

6. Place scissor onto jaw ring and start pressing process; hold the press-button until the scissor has engaged the jaw ring.

7. Remove scissor from jaw ring and then remove jaw ring from fitting, remove identify plastic blue film to indicate press has been completed.

Product Installation Instructions

5.3 AQUApipe Stainless Steel DN150 to DN250

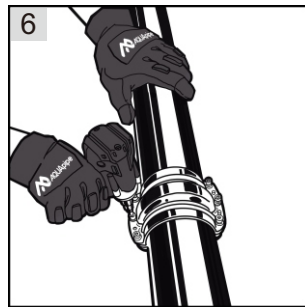
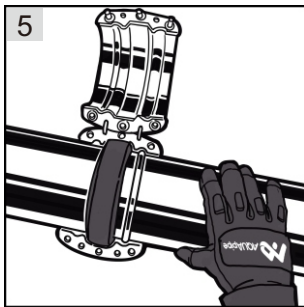
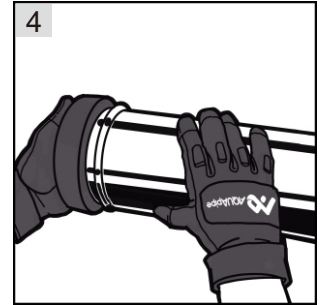
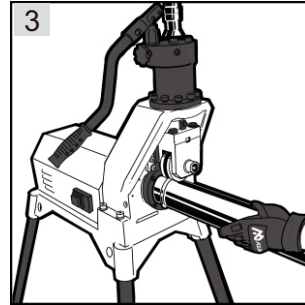
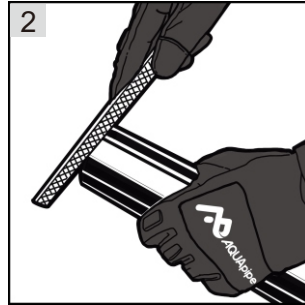
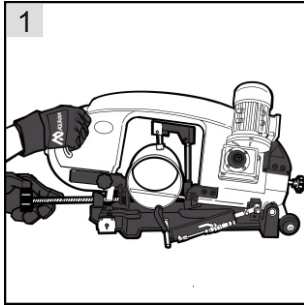

1. Use pipe cutter to cut the pipe at right angles.

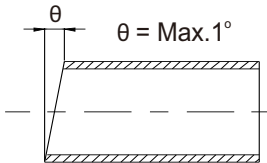

2. Deburr inside and outside of pipe.

3. Use AQUApipe Lugging machine to lug the pipe, proper lugs height are request. (AQUApipe's pipes from factory are supplied with lugs at both end).

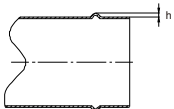

Pipe Size	h(mm)
DN150	3.8~4.0
DN200	3.8~4.0
DN250	3.8~4.0

4. Open the clamshell and insert pipe into the seal to 2-3cm on each side.

5. Position the clamshell over the sealing, ensuring the lugs align with the grooves.

6. Flush the two clamshells together, respecting the max. torque.

Pipe Size	Bolt	Max. Torque	Allen Key
DN150	M10	65	8mm
DN200	M10	65	8mm
DN250	M12	118	10mm

Part 6 - Dimensional Information

6.1 AQUApipe Stainless Steel 15mm to 108mm

* Dimensions in mm.

PIPE TO PIPE JOINT

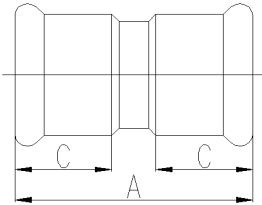

PN	SIZE	A	C
304 NBR			
542 02 0000 02	18	49	20.5
542 02 0100 02	22	53	21
542 02 0200 02	28	58	23
542 02 0300 02	35	65	27
542 02 0400 02	42	76	32
542 02 0500 02	54	87	37
542 02 1400 02	76.1	143	55
542 02 0700 02	88.9	164	63
542 02 0800 02	108	196	77

SLONG SLIDE PIPE TO PIPE JOINT

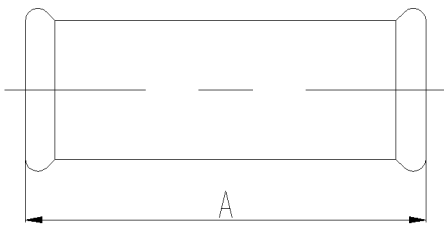

PN	SIZE	A
304 NBR		
542 02 0099 02	18	82
542 02 0199 02	22	85
542 02 0299 02	28	96
542 02 0399 02	35	105
542 02 0499 02	42	120
542 02 0599 02	54	138
542 02 1499 02	76.1	220
542 02 0799 02	88.9	250
542 02 0899 02	108	300

90° ELBOW

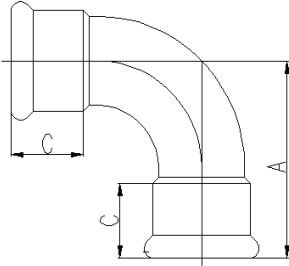

PN	SIZE	A	C
304 NBR			
542 03 0000 02	18	47	20.5
542 03 0100 02	22	52.5	21
542 03 0200 02	28	62	23
542 03 0300 02	35	72	27
542 03 0400 02	42	88	32
542 03 0500 02	54	110	37
542 03 1400 02	76.1	170	55
542 03 0700 02	88.9	198	63
542 03 0800 02	108	238	77

IN-OUT 90° ELBOW

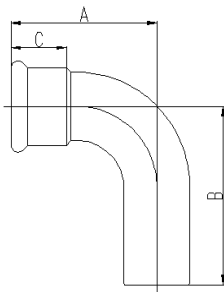

PN	SIZE	A	B	C
304 NBR				
542 03 0001 02	18	47	52	20.5
542 03 0101 02	22	52.5	58	21
542 03 0201 02	28	62	73	23
542 03 0301 02	35	72	87	27
542 03 0401 02	42	88	100	32
542 03 0501 02	54	110	128	37
542 03 1401 02	76.1	170	186.5	55
542 03 0701 02	88.9	198	214	63
542 03 0801 02	108	238	253	77

45° ELBOW

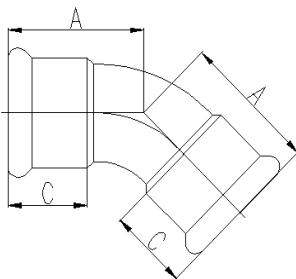

PN	SIZE	A	C
304 NBR			
542 04 0000 02	18	32	20.5
542 04 0100 02	22	36	21
542 04 0200 02	28	40.5	23
542 04 0300 02	35	47	27
542 04 0400 02	42	57	32
542 04 0500 02	54	69	37
542 04 1400 02	76.1	110	55
542 04 0700 02	88.9	128	63
542 04 0800 02	108	153	77

IN-OUT 45° ELBOW

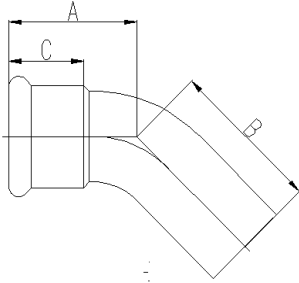

PN	SIZE	A	B	C
304 NBR				
542 04 0001 02	18	32	34	20.5
542 04 0101 02	22	36	39	21
542 04 0201 02	28	40.5	48	23
542 04 0301 02	35	47	54	27
542 04 0401 02	42	57	66	32
542 04 0501 02	54	69	82	37
542 04 1401 02	76.1	110	126.5	55
542 04 0701 02	88.9	128	144	63
542 04 0801 02	108	153	168	77

EQUAL TEE

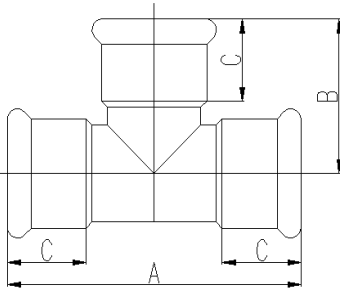

PN	SIZE	A	B	C
304 NBR				
542 05 0000 02	18	70	35.5	20.5
542 05 0100 02	22	77	39	21
542 05 0200 02	28	88	44.5	23
542 05 0300 02	35	102	51.5	27
542 05 0400 02	42	120	60.5	32
542 05 0500 02	54	144	72.5	37
542 05 1400 02	76.1	232	116	55
542 05 0700 02	88.9	262	131	63
542 05 0800 02	108	312	156	77

END CAP

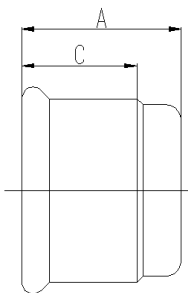

PN	SIZE	A	C
304 NBR			
542 06 0000 02	18	34.5	20.5
542 06 0100 02	22	34.5	21
542 06 0200 02	28	37.5	23
542 06 0300 02	35	41	27
542 06 0400 02	42	46	32
542 06 0500 02	54	52	37
542 06 1400 02	76.1	85.5	55
542 06 0700 02	88.9	96	63
542 06 0800 02	108	114.5	77

REDUCING TEE

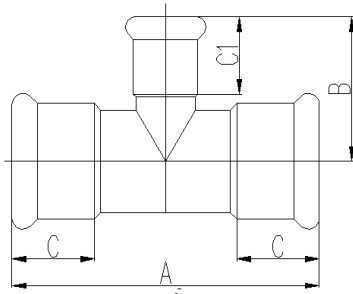

PN	SIZE	A	B	C	C1
304 NBR					
542 07 0100 02	22-18	77	40.5	21	20.5
542 07 0200 02	28-18	88	42.5	23	20.5
542 07 0201 02	28-22	88	42.5	23	21
542 07 0300 02	35-18	102	46.5	27	20.5
542 07 0301 02	35-22	102	46.5	27	21
542 07 0302 02	35-28	102	49.5	27	23
542 07 0400 02	42-18	120	50	32	20.5
542 07 0401 02	42-22	120	50	32	21
542 07 0402 02	42-28	120	53	32	23
542 07 0403 02	42-35	120	56.5	32	27
542 07 0500 02	54-18	144	56	37	20.5
542 07 0501 02	54-22	144	56	37	21
542 07 0502 02	54-28	144	59	37	23
542 07 0503 02	54-35	144	62.5	37	27
542 07 0504 02	54-42	144	68	55	32
542 07 1401 02	76.1-22	232	80.5	55	21
542 07 1402 02	76.1-28	232	86	55	23
542 07 1403 02	76.1-35	232	93	55	27
542 07 1404 02	76.1-42	232	102	55	32
542 07 1405 02	76.1-54	232	114	55	37
542 07 0701 02	88.9-22	262	87	63	21
542 07 0702 02	88.9-28	262	92.5	63	23
542 07 0703 02	88.9-35	262	99.5	63	27
542 07 0704 02	88.9-42	262	108.5	63	32
542 07 0705 02	88.9-54	262	120	63	37
542 07 0801 02	108-22	262	96.5	77	21
542 07 0802 02	108-28	262	102	77	23
542 07 0803 02	108-35	312	109	77	27
542 07 0804 02	108-42	312	118	77	32
542 07 0805 02	108-54	312	130	77	37
542 07 0814 02	108-76.1	312	129.5	77	55

REDUCING TEE

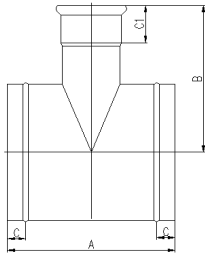

PN	SIZE	A	B	C	C1
304 NBR					
542 07 1005 02	DN150-54	272.5	154.5	34.5	37
542 07 1008 02	DN150-108	310	238.5	34.5	77
542 07 1105 02	DN200-54	265	184.5	34.5	37
542 07 1108 02	DN200-108	310	268.5	34.5	77
542 07 1205 02	DN250-54	269	211.5	34.5	37
542 07 1208 02	DN250-108	315	295.5	34.5	77

90° ELBOW FEMALE (BSP)

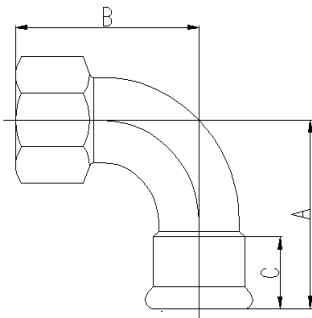

PN	SIZE	A	B	C
304 NBR				
542 13 0000 02	18-1/2"	47	48	20.5
542 13 0001 02	18-3/4"	47	48	20.5
542 13 0100 02	22-1/2"	52.5	52	21
542 13 0101 02	22-3/4"	52.5	53	21
542 13 0201 02	28-3/4"	62	57	23
542 13 0202 02	28-1"	62	63	23
542 13 0303 02	35-1 1/4"	72	74	27
542 13 0404 02	42-1 1/2"	88	84	32
542 13 0505 02	54-2"	110	105	37

90° ELBOW MALE (BSP)

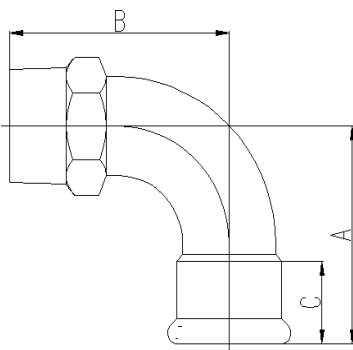

PN	SIZE	A	B	C
304 NBR				
542 15 0000 02	18-1/2"	47	52	20.5
542 15 0100 02	22-1/2"	52.5	55	21
542 15 0101 02	22-3/4"	52.5	58	21
542 15 0201 02	28-3/4"	62	63	23
542 15 0202 02	28-1"	62	68	23
542 15 0302 02	35-1"	72	76	27
542 15 0303 02	35-1 1/4"	72	79	27
542 15 0403 02	42-1 1/4"	88	87	32
542 15 0404 02	42-1 1/2"	88	88	32
542 15 0504 02	54-1 1/2"	110	103	37
542 15 0505 02	54-2"	110	111	37

THREAD JOINT MALE (BSP)

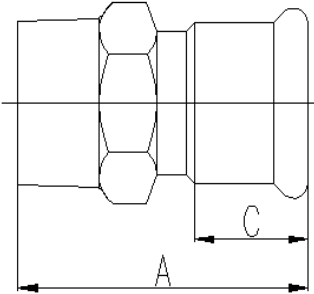

PN	SIZE	A	C
304 NBR			
542 17 0000 02	18-1/2"	54	20.5
542 17 0001 02	18-3/4"	55.5	20.5
542 17 0100 02	22-1/2"	51	21
542 17 0101 02	22-3/4"	54.5	21
542 17 0102 02	2-1"	59	21
542 17 0200 02	28-1/2"	71.5	23
542 17 0201 02	28-3/4"	57.5	23
542 17 0202 02	28-1"	62	23
542 17 0203 02	28-1 1/4"	65	23
542 17 0302 02	35-1"	65	27
542 17 0303 02	35-1 1/4"	68	27
542 17 0304 02	35-1 1/2"	69	27
542 17 0403 02	42-1 1/4"	74	32
542 17 0404 02	42-1 1/2"	75	32
542 17 0504 02	54-1 1/2"	80	37
542 17 0505 02	54-2"	88	37

THREAD JOINT FEMALE (BSP)

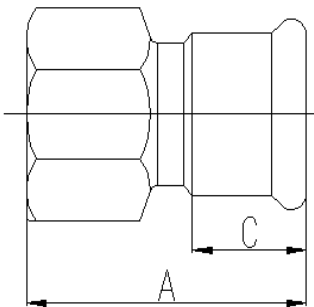

PN	SIZE	A	C
304 NBR			
542 19 0000 02	18-1/2"	50	20.5
542 19 0001 02	18-3/4"	50	20.5
542 19 0100 02	22-1/2"	48	21
542 19 0101 02	22-3/4"	49	21
542 19 0102 02	2-1"	54	21
542 19 0200 02	28-1/2"	67.5	23
542 19 0201 02	28-3/4"	52	23
542 19 0202 02	28-1"	57	23
542 19 0203 02	28-1 1/4"	60	23
542 19 0302 02	35-1"	61	27
542 19 0303 02	35-1 1/4"	63	27
542 19 0304 02	35-1 1/2"	65	27
542 19 0403 02	42-1 1/4"	69	32
542 19 0404 02	42-1 1/2"	71	32
542 19 0504 02	54-1 1/2"	76	37
542 19 0505 02	54-2"	82	37

PIPE REDUCER

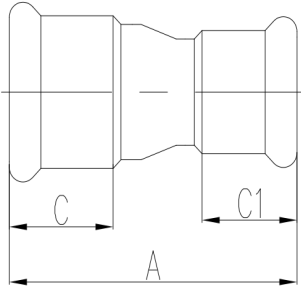

PN	SIZE	A	C	C1
304 NBR				
542 21 0200 02	28-18	69	23	20.5
542 21 0201 02	28-22	65	23	21
542 21 0302 02	35-28	73	27	23
542 21 0403 02	42-35	86	32	27
542 21 0504 02	54-42	99	37	32
542 21 1405 02	76.1-54	132.5	55	37
542 21 0714 02	88.9-76.1	168.5	63	55
542 21 0807 02	108-88.9	196.5	77	63
542 21 1008 02	DN150-108	270	34.5	77
542 21 1108 02	DN200-108	280	34.5	77

IN-OUT REDUCER

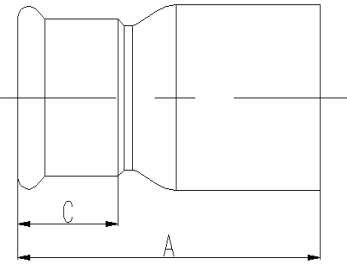

PN	SIZE	A	C
304 NBR			
542 22 0100 02	22-18	60	20.5
542 22 0200 02	28-18	68	20.5
542 22 0201 02	28-22	67	21
542 22 0300 02	35-18	78	20.5
542 22 0301 02	35-22	84	21
542 22 0302 02	35-28	83	23
542 22 0400 02	42-18	87	20.5
542 22 0401 02	42-22	87	21
542 22 0402 02	42-28	82	23
542 22 0403 02	42-35	87	27
542 22 0500 02	54-18	93	20.5
542 22 0501 02	54-22	93	21
542 22 0502 02	54-28	94	23
542 22 0503 02	54-35	108	27
542 22 0504 02	54-42	98	32
542 22 1405 02	76.1-54	141	37
542 22 0705 02	88.9-54	152	37
542 22 0805 02	108-54	169	37
542 22 0814 02	108-76.1	186.5	55
542 22 0807 02	108-88.9	198.5	63

MALE BSP 3-PIECES ADAPTER

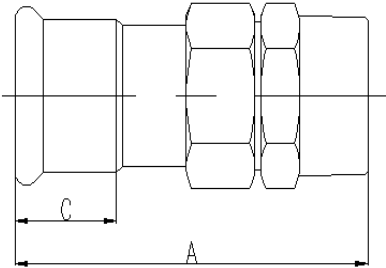

PN	SIZE	A	C
304 NBR			
542 49 0000 02	18-1/2"	83	20.5
542 49 0001 02	18-3/4"	84	20.5
542 49 0100 02	22-1/2"	88	21
542 49 0101 02	22-3/4"	88	21
542 49 0102 02	22-1"	92	21
542 49 0201 02	28-3/4"	91	23
542 49 0202 02	28-1"	93	23
542 49 0303 02	35-1 1/4"	98.5	27
542 49 0304 02	35-1 1/2"	104	27
542 49 0404 02	42-1 1/2"	113.5	32
542 49 0505 02	54-2"	118.5	37

FEMALE BSP SWIVEL NUT ADAPTER

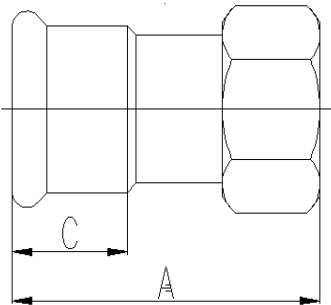

PN	SIZE	A	C
304 NBR			
542 50 0000 02	18-1/2"	58	20.5
542 50 0001 02	18-3/4"	57	20.5
542 50 0101 02	22-3/4"	62	21
542 50 0102 02	22-1"	60	21
542 50 0202 02	28-1"	63	23
542 50 0203 02	28-1 1/4"	63	23
542 50 0303 02	35-1 1/4"	67.5	27
542 50 0304 02	35-1 1/2"	71.5	27
542 50 0404 02	42-1 1/2"	77	32
542 50 0405 02	42-2"	77	32
542 50 0505 02	54-2"	82.5	37

**LOCKABLE BALL VALVE
FEMALE (BSP)**

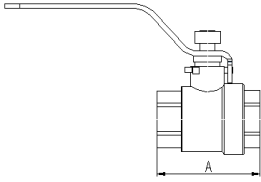

PN	SIZE	A
304 NBR		
501 52 0000 02	1/2"	51
501 52 0100 02	3/4"	62.5
501 52 0200 02	1"	68.5
542 52 0300 02	1 1/4"	82.5
542 52 0400 02	1 1/2"	97.5
542 52 0500 02	2"	105.5

**LOCKABLE BALL VALVE,
MALE (BSP)**

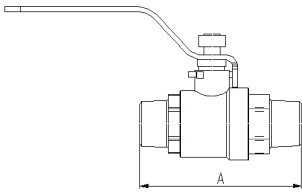

PN	SIZE	A
304 NBR		
501 52 0001 02	1/2"	78.5
501 52 0101 02	3/4"	91
501 52 0201 02	1"	89.5
542 52 0301 02	1 1/4"	139
542 52 0401 02	1 1/2"	134
542 52 0501 02	2"	152

**LOCKABLE BALL VALVE,
FEMALE-MALE (BSP)**

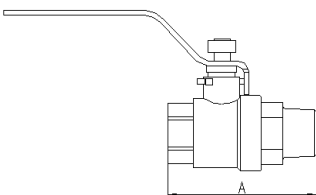

PN	SIZE	A
304 NBR		
501 52 0002 02	1/2"	68.5
501 52 0102 02	3/4"	76.5
501 52 0202 02	1"	78.5
542 52 0302 02	1 1/4"	106.5
542 52 0402 02	1 1/2"	115.5
542 52 0502 02	2"	122

**SHORT THREAD TEE
MALE (BSP)**

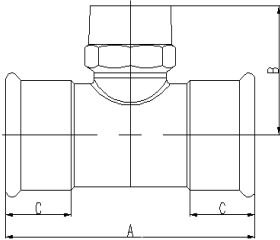

PN	SIZE	A	B	C
304 NBR				
542 65 0000 02	18-1/2"	70	40	20.5
542 65 0001 02	18-3/4"	70	41.5	20.5
542 65 0100 02	22-1/2"	77	42.5	21
542 65 0101 02	22-3/4"	77	43	21
542 65 0200 02	28-1/2"	88	44.5	23
542 65 0201 02	28-3/4"	88	46	23
542 65 0202 02	28-1"	88	50.5	23
542 65 0301 02	35-3/4"	102	50	27
542 65 0303 02	35-1 1/4"	102	57.5	27
542 65 0401 02	42-3/4"	120	53.5	32
542 65 0404 02	42-1 1/2"	120	61.5	37
542 65 0501 02	54-3/4"	144	59.5	37
542 65 0505 02	54-2"	144	76	37

**SHORT THREAD TEE
FEMALE (BSP)**

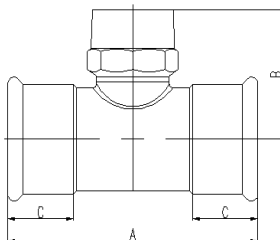

PN	SIZE	A	B	C
304 NBR				
542 67 0000 02	18-1/2"	70	36	20.5
542 67 0001 02	18-3/4"	70	36	20.5
542 67 0100 02	22-1/2"	77	38.5	21
542 67 0101 02	22-3/4"	77	37.5	21
542 67 0200 02	28-1/2"	88	40.5	23
542 67 0201 02	28-3/4"	88	40.5	23
542 67 0202 02	28-1"	88	45.5	23
542 67 0300 02	35-1/2"	102	44.5	27
542 67 0301 02	35-3/4"	102	44.5	27
542 67 0302 02	35-1"	102	49.5	27
542 67 0303 02	35-1 1/4"	102	52.5	27
542 67 0400 02	42-1/2"	120	48	32
542 67 0401 02	42-3/4"	120	48	32
542 67 0404 02	42-1 1/2"	120	57.5	32
542 67 0500 02	54-1/2"	144	54	37
542 67 0501 02	54-3/4"	144	54	37
542 67 0505 02	54-2"	144	70	37
542 67 1401 02	76.1-3/4"	232	66	55
542 67 1405 02	76-2"	232	82	55
542 67 0701 02	88.9-3/4"	262	72.5	63
542 67 0705 02	88.9-2"	262	88.5	63
542 67 0801 02	108-3/4"	312	82	77
542 67 0805 02	108-2"	312	98	77

SHORT ELBOW FEMALE (BSP)

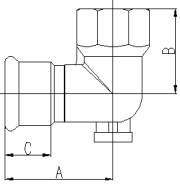

PN	SIZE	A	B	C
304 NBR				
542 68 0000 02	18-1/2"	50	28	20.5
542 68 0100 02	22-1/2"	49	27	21
542 68 0101 02	22-3/4"	53	35	21
542 68 0200 02	28-1/2"	65.5	24	23
542 68 0202 02	28-1"	56	42.5	23

FLANGE JOINT

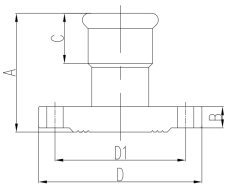

PN	SIZE	A	B	C	D	D1
304 NBR						
542 70 0500 02	DN50-54	85	19	37	165	125
542 70 1400 02	DN65-76.1	128	20	55	185	145
542 70 0700 02	DN80-88.9	143	20	63	200	160
542 70 0800 02	DN100-108	168	22	77	220	180

* ISO EN1092-1 flanges.

REDUCING FLANGE JOINT

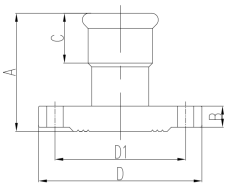

PN	SIZE	A	B	C	D	D1
304 NBR						
542 71 1405 02	DN65-54	84	20	37	165	145
542 71 1407 02	DN65-88.9	124	20	63	185	145
542 71 0714 02	DN80-76.1	128	20	55	200	160
542 71 0708 02	DN80-108	141.5	20	77	200	160
542 71 0807 02	DN100-88.9	143	22	63	220	180
542 71 0908 02	DN125-108	168	22	77	250	210

* ISO EN1092-1 flanges.

Dimensional Information

6.2 AQUApipe Stainless Steel DN150 to DN250

* Dimensions in mm.

PIPE TO PIPE JOINT

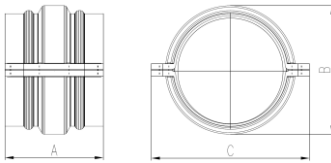

PN	SIZE	A	B	C
304 NBR				
501 02 1001 05	DN150	143	230	189
501 02 1101 05	DN200	143	292.5	249
501 02 1101 02	DN250	111	337	313

90° ELBOW

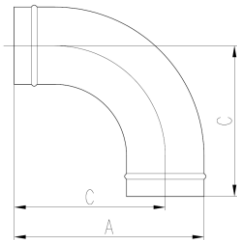

PN	SIZE	A	C
304			
501 03 1000 03	DN150	365	282.5
501 03 1100 03	DN200	476	363.5
501 03 1200 03	DN250	558	418

45° ELBOW

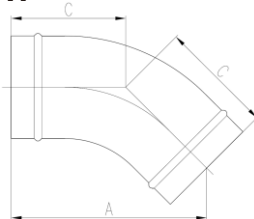

PN	SIZE	A	C
304			
501 04 1000 03	DN150	272	159
501 04 1100 03	DN200	330.5	193.5
501 04 1200 03	DN250	373.5	219

EQUAL TEE

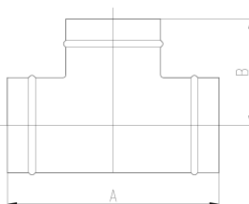

PN	SIZE	A	B
304			
501 05 1000 03	DN150	339	169.5
501 05 1100 03	DN200	396	200
501 05 1200 03	DN250	466	233

END CAP

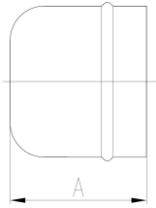

PN	SIZE	A
304		
501 06 1000 03	DN150	130
501 06 1100 03	DN200	144
501 06 1200 03	DN250	165

REDUCING TEE

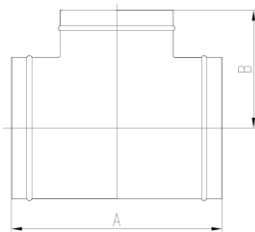

PN	SIZE	A	B
304			
501 07 1110 03	DN200-DN150	338	199.5
501 07 1210 03	DN250-DN150	349	228
501 07 1211 03	DN250-DN200	407	227

REDUCING PIPE TO PIPE JOINT

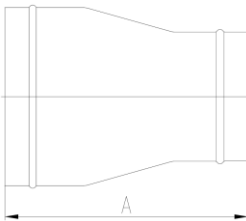

PN	SIZE	A
304		
501 21 1110 03	DN200-DN150	300
501 21 1210 03	DN250-DN150	331
501 21 1211 03	DN250-DN200	336

FLANGE JOINT

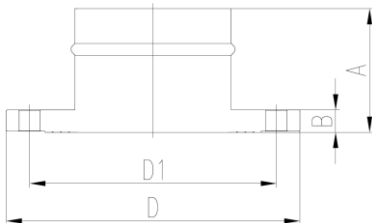

PN	SIZE	A	B	D	D1
304					
501 70 1000 03	DN150	122	24	285	240
501 70 1100 03	DN200	130.5	26	340	295
501 70 1200 03	DN250	138	29	405	355

* ISO EN1092-1 flanges.

REDUCING FLANGE JOINT

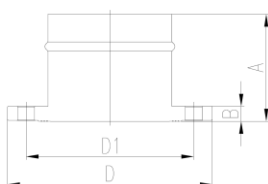

PN	SIZE	A	B	D	D1
304					
501 71 0910 03	DN125-DN150	128	22	250	210
501 71 1110 03	DN200-DN150	108	26	340	295
501 71 1211 03	DN250-DN200	112	29	405	355

* ISO EN1092-1 flanges.



Part 7 - Limited Warranty

AQUApipe 10-year limited warranty

The AIRpipe Group warrants to end users, installers and distributors that AQUApipe stainless steel products when properly installed in industrial applications to be free from failure caused by manufacturing defects for a period of ten (10) years from the date of product purchase.

Industrial applications are defined as non-residential and non-commercial applications not normally accessible to the general public, including manufacturing, mining, process or fabrication environments.

AIRpipe company does not warrant the design, assembly or installation of the system, but only the components with an official AQUApipe logo. AIRpipe is not responsible for improper assembly, installation, or for any modifications of the product.

Under this Limited Warranty, you only have a right to a remedy if the failure or leak resulted from a manufacturing defect in the AQUApipe product and the failure or leak occurs during the warranty period. The warranty remedy does not apply if the failure or any resulting damage is caused by:

1. Not designing, installing, inspecting, testing or maintaining the AQUApipe product in accordance with AQUApipe's installation instructions and other specifications and approvals applicable to the installation;
2. Alteration, misuse or abuse of, or damage to the products;
3. Operation beyond the design range, excessive pressure, stress, or mishandling in any way;
4. improper handling and protection of the AQUApipe product prior to, during and after installation, inadequate freeze protection, or exposure to environmental or operating conditions not recommended for the application;
5. Use other than for the intended purpose or in a manner other than specified by AIRpipe company;
6. Use of components other than those sold by AIRpipe company;
7. acts of nature, such as, but not limited to earthquakes, fire, or weather damage.

Final approval as to use compatibility to a specific process or fluid application is the responsibility of the design or installation people and this Limited Warranty only applies to manufacturing defects in the AQUApipe Product.

In the event of a leak or other failure in the AQUApipe product covered by this warranty, it is the responsibility of the end user to take appropriate measures to diminish any damage, to include making timely repairs. Only if the warranty applies will AIRpipe be responsible for the remedy under this warranty. The parts which you claim failed should be kept and AIRpipe company contacted by email or through the local AQUApipe sales representative within seven calendar days after the leak or other failure and identifying yourself as having a warranty claim. You should be prepared to ship, at your expense, the product which you claim failed due to a manufacturing defect, document the date of installation, and the amount of the repair or replacement if performed by you. Within a reasonable time after receiving the product, AIRpipe will investigate the reasons for the failure, which includes the right to inspect the product at a AIRpipe location and reasonable access to the site of damage. AIRpipe will notify you in writing as to the results of its review.

In the event that AIRpipe determines that the failure or leak was the result of a manufacturing defect in the AQUApipe product covered by this warranty and to which this warranty applies, the **EXCLUSIVE AND ONLY REMEDY** under this warranty shall be the reimbursement for reasonable charges for repair or replacement of the AQUApipe product itself. **AIRPIPE COMPANY SHALL NOT BE LIABLE FOR CONSEQUENTIAL OR OTHER DAMAGE (FOR EXAMPLE, ECONOMIC LOSS, WATER OR PROPERTY OR MOLD REMEDIATION) UNDER ANY LEGAL THEORY, FOR CONTRIBUTION OR INDEMNITY OR OTHERWISE.**

This Limited Warranty gives you specific legal rights and you also may have other rights which may vary from the country. This warranty shall be interpreted and applied under the law of the country in which the product is installed and is intended as a Commercial Warranty.



AIRpipe Corporation

No.18 Moganshan Road, Beilun District, Ningbo, China
Tel: +86 574 5571 2687
www.airpipetech.com
info@airpipetech.com

AIRpipe Europe

4 impasse Augustin Fresnel, 44800 Saint-Herblain, France
Tel: +33 (0)2 40 05 10 20
www.airpipe-europe.com
contact@airpipe-Europe.com