



aerospace  
climate control  
electromechanical  
filtration  
fluid & gas handling  
hydraulics  
**pneumatics**  
process control  
sealing & shielding



# Pneumatic cylinders

Series P1M  
Compact cylinders



ENGINEERING YOUR SUCCESS.

Features	Air cylinder	Hydraulic cylinder	Electro mechanical actuators
Overload safe	***	***	*
Easy to limit force	***	***	*
Easy to vary speed	***	***	*
Speed	***	**	**
Reliability	***	***	***
Robustness	***	***	*
Installation cost	***	*	**
Ease of service	***	**	*
Safety in damp environments	***	***	*
Safety in explosive atmospheres	***	***	*
Safety risk with electrical installations	***	***	*
Risk of oil leak	***	*	***
Clean, hygienic	***	**	*
Standardised measurements	***	***	*
Service life	***	***	*
Hydraulic system required	***	*	***
Weight	***	**	**
Purchase price	***	**	*
Power density	**	***	*
Noise level during operation	**	***	**
High force for size	**	***	*
Positioning possibilities	*	***	***
Total energy consumption	*	**	***
Service interval	*	**	***
Compressor capacity required	*	***	***

\* = good, \*\*=average, \*\*\*=excellent



**Important**  
 Before attempting any external or internal work on the cylinder or any connected components, make sure the cylinder is vented and disconnect the air supply in order to ensure isolation of the air supply.



**Note**  
 All technical data in this catalogue are typical data only.  
 Air quality is essential for maximum cylinder service life (see ISO 8573).



**WARNING**

**FAILURE OR IMPROPER SELECTION OR IMPROPER USE OF THE PRODUCTS AND/OR SYSTEMS DESCRIBED HEREIN OR RELATED ITEMS CAN CAUSE DEATH, PERSONAL INJURY AND PROPERTY DAMAGE.**

This document and other information from Parker Hannifin Corporation, its subsidiaries and authorized distributors provide product and/or system options for further investigation by users having technical expertise. It is important that you analyze all aspects of your application and review the information concerning the product or system in the current product catalog. Due to the variety of operating conditions and applications for these products or systems, the user, through its own analysis and testing, is solely responsible for making the final selection of the products and systems and assuring that all performance, safety and warning requirements of the application are met. The products described herein, including without limitation, product features, specifications, designs, availability and pricing, are subject to change by Parker Hannifin Corporation and its subsidiaries at any time without notice.

**SALE CONDITIONS**

The items described in this document are available for sale by Parker Hannifin Corporation, its subsidiaries or its authorized distributors. Any sale contract entered into by Parker will be governed by the provisions stated in Parker's standard terms and conditions of sale (copy available upon request).

<b>Contents</b>	<b>Page</b>
General information .....	4-5
Cylinder forces .....	6
Main data: P1M .....	7
Material specification .....	7
Cushioning diagram .....	7
Working medium, air quality .....	7
Guide for selecting suitable tubing .....	8
Valve series with respective flows in NI/minute .....	9
Dimensions, .....	10-13
Order key .....	14
Standard stroke length in mm .....	14
Order code standard strokes, double acting .....	15-16
Order code standard strokes, single acting .....	17
Cylinder mountings .....	18-25
Sensors .....	26-28
Sensors for special applications .....	29-30
Connecting cables with one connector .....	31
Male connectors for connecting cables .....	31
Ready to use connecting cables with connectors at each end .....	31
Connection block Valvetronic 110 .....	32
Seal kits and Grease for P1M .....	33

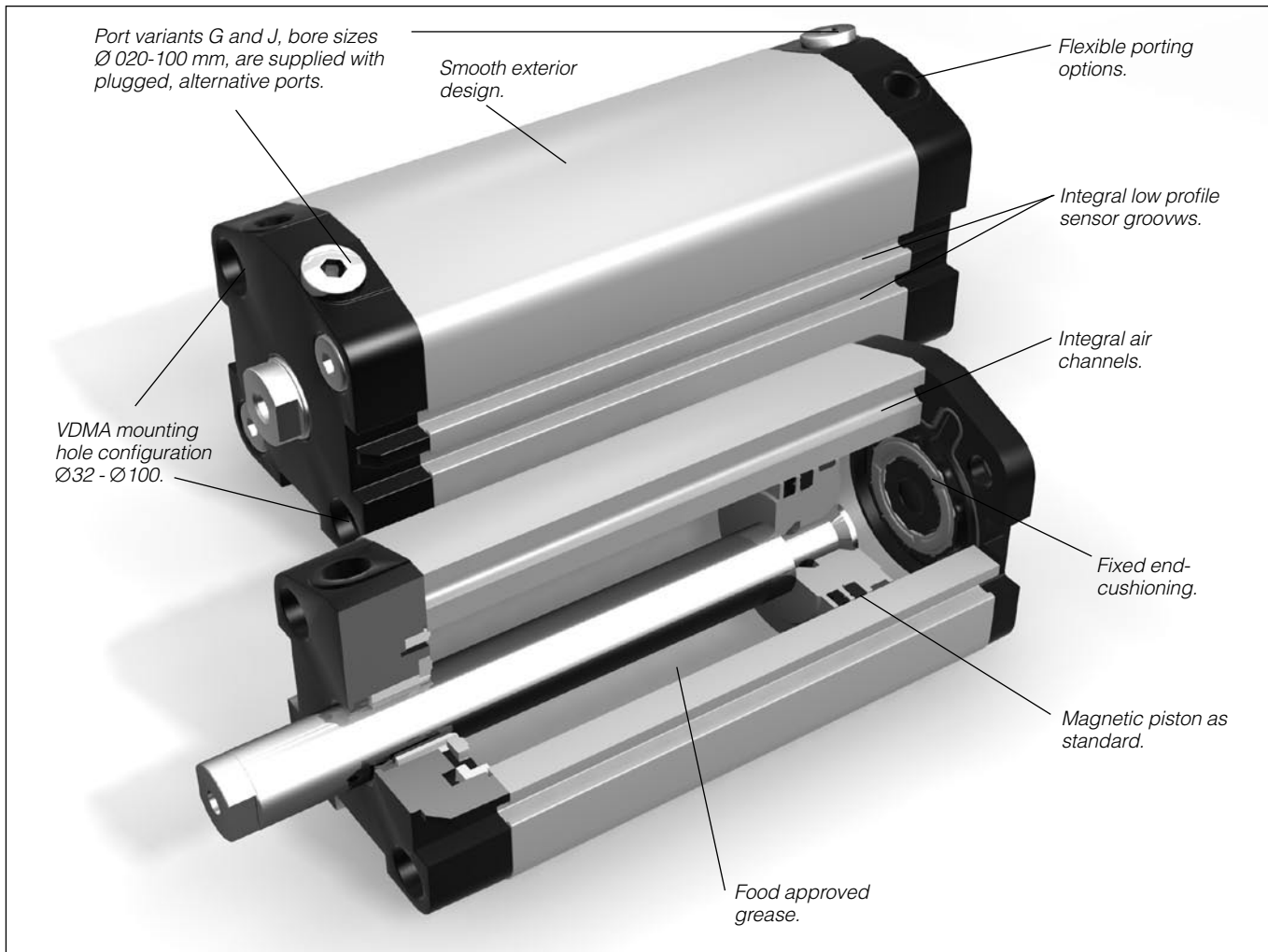

## Short Build Cylinders

Parker Pneumatic's versatile range of Short Build Cylinders, with unique porting options, integral sensor grooves and one of the shortest overall lengths on the market is suitable for a wide range of applications.

The range comprises ten cylinder bore sizes, 12 - 100 mm diameter, with stroke lengths from 5 to 500 mm and, as with other Parker cylinders, Short Build Cylinders are factory-lubricated with food grade grease (USDA).

The extremely small overall dimensions have been achieved through an entirely new design. Channels in the body supply air to either end of the cylinder. This means that the connection ports in the front or rear end walls can be configured to suit individual requirements. Port variants G and J, bore sizes  $\varnothing$  020-100 mm, are also supplied with plugged, alternative ports, which permit a free choice of connections.

The flexible porting option, together with a choice of mounting methods, ensures that this range of cylinders can be used in variety of applications. It is especially suitable for use in applications where space is limited as, for example, in the packaging or electronic industries.

## Options

In addition to the basic version with stainless steel piston rod, magnetic piston and fixed end cushioning, the range will include several standard options that provide a wide range of choices.

Options include single acting cylinders, through rod and hollow through rod, male or female threaded rods and high-temperature versions.

## Sensors and accessories

The P1M-series incorporates a further unique feature: integral sensor grooves. The grooves are recessed into the barrel, enabling sensors to be quickly and easily fitted without increasing external dimensions. Double grooves allow sensors to be grouped together.

Hole patterns for the mountings, as for all the mounts in the complete range of mountings, comply with the VDMA-standards.

## Fixed-cushioning

Bumpers in Polyurethane as standard.

## Smooth external design

The end plates have no recesses or other grooves that could collect dirt or liquid. Cleaning is easy and effective.

## Flexible port location

The P1M is available with several different port locations. Both ports in the front end wall (H), which gives extremely short installation dimensions, both ports in the rear end wall (J), or one port in the front wall and one in the rear wall (G) as in a conventional cylinder.

Port variants G and J, bore sizes  $\varnothing$  020-100 mm, are also supplied with plugged, alternative ports in the front and rear end walls, which permits a free choice of connections.

## Position sensing

All cylinders in standard temperature design are fitted with a magnet for position sensing. Electronic type sensors and reed switches are available. They are supplied with either flying lead or cable plug connector.

## Complete range of mountings

A complete range of mounting accessories is available.

## Variants

In addition to the basic design, several standard variants of these Short Built Cylinders are available to fulfill more demanding requirements in terms of performance and environmental conditions:

- Cylinders with special stroke lengths
- Cylinders with extended piston rods
- Cylinders with male piston rod thread
- Through piston rods
- Through hollow piston rods

Single-acting cylinders with spring return, push and pull

Cylinders with axial connections.  
High-temperature versions for operation in temperature range from -10 °C to +150 °C (not magnetic pistons, not bumpers)



Double acting, ports in front and rear plate



Double acting, both ports in front plate



Double acting, both ports in rear plate radially



Single acting



Through piston rod



Through hollow piston rod



Male rod end



**Cylinder forces, double acting variants**

Cyl. bore/ pist. rod mm	Stroke	Piston area cm <sup>2</sup>	Max theoretical force in N (bar)									
			1,0	2,0	3,0	4,0	5,0	6,0	7,0	8,0	9,0	10,0
<b>12/6</b>	+	1,1	11	23	34	45	57	<b>68</b>	79	90	102	113
	-	0,8	8	17	25	34	42	<b>51</b>	59	68	76	85
<b>16/8</b>	+	2,0	20	40	60	80	100	<b>120</b>	141	161	181	201
	-	1,5	15	30	45	60	75	<b>90</b>	106	121	136	151
<b>20/10</b>	+	3,1	31	63	94	126	157	<b>188</b>	220	251	283	314
	-	2,3	23	46	69	92	115	<b>138</b>	161	184	207	231
<b>25/10</b>	+	4,9	49	98	147	196	245	<b>295</b>	344	393	442	491
	-	4,1	41	82	124	165	206	<b>247</b>	289	330	371	412
<b>32/12</b>	+	8,0	80	161	241	322	402	<b>483</b>	563	643	724	804
	-	6,9	69	138	207	276	346	<b>415</b>	484	553	622	691
<b>40/16</b>	+	12,6	126	251	377	503	628	<b>754</b>	880	1005	1131	1257
	-	10,6	106	211	317	422	528	<b>633</b>	739	844	950	1056
<b>50/20</b>	+	19,6	196	393	589	785	982	<b>1178</b>	1374	1571	1767	1963
	-	16,5	165	330	495	660	825	<b>990</b>	1155	1319	1484	1649
<b>63/20</b>	+	31,2	312	623	935	1247	1559	<b>1870</b>	2182	2494	2806	3117
	-	28,0	280	561	841	1121	1402	<b>1682</b>	1962	2242	2523	2803
<b>80/25</b>	+	50,3	503	1005	1508	2011	2513	<b>3016</b>	3519	4021	4524	5027
	-	45,4	454	907	1361	1814	2268	<b>2721</b>	3175	3629	4082	4536
<b>100/25</b>	+	78,5	785	1571	2356	3142	3927	<b>4712</b>	5498	6283	7069	7854
	-	73,6	736	1473	2209	2945	3682	<b>4418</b>	5154	5890	6627	7363

+ = Outward stroke  
- = Return stroke

**Note!**

Select a theoretical force 50-100% larger than the force required

**Cylinder forces**

Indicated cylinder forces are theoretical and should be reduced according to the working conditions.

Cylinder designation	Theoretical cylinder force at 6 bar				Cylinder designation	Theoretical cylinder force at 6 bar			
	expanding stroke		spring retraction			expanding stroke		spring retraction	
	Nmax	Nmin	Nmax	Nmin		Nmax	Nmin	Nmax	Nmin
<b>Single acting, spring return for retract stroke</b>					<b>Single acting, spring return for advanced stroke</b>				
P1M012VR•A••005	59	55	12	8	P1M012VE•A••005	43	36	14	7
P1M012VR•A••010	63	55	12	4	P1M012VE•A••010	45	40	10	5
P1M016VR•A••005	107	102	18	13	P1M016VE•A••005	80	69	22	11
P1M016VR•A••010	111	102	18	9	P1M016VE•A••010	84	75	16	7
P1M020VR•A••005	176	169	17	12	P1M020VE•A••005	129	123	19	13
P1M020VR•A••010	180	169	17	8	P1M020VE•A••010	130	119	23	12
P1M025VR•A••005	276	271	23	18	P1M025VE•A••005	232	224	23	15
P1M025VR•A••010	281	271	23	13	P1M025VE•A••010	233	217	30	14
P1M032VR•A••005	464	453	29	18	P1M032VE•A••005	387	379	35	27
P1M032VR•A••010	469	453	29	13	P1M032VE•A••010	395	379	35	19
P1M040VR•A••005	726	720	34	28	P1M040VE•A••005	587	577	56	46
P1M040VR•A••010	732	720	34	22	P1M040VE•A••010	598	577	56	35
P1M050VR•A••010	1126	1115	63	52	P1M050VE•A••010	951	928	61	38
P1M050VR•A••025	1141	1105	73	37	P1M050VE•A••025	947	901	88	42
P1M063VR•A••010	1818	1807	63	52	P1M063VE•A••010	1643	1625	56	38
P1M063VR•A••025	1833	1797	73	37	P1M063VE•A••025	1639	1593	88	42
P1M080VR•A••010	2910	2888	128	106	P1M080VE•A••010	2593	2525	196	128
P1M080VR•A••025	2942	2888	128	74	P1M080VE•A••025	2621	2531	190	100
P1M100VR•A••010	4606	4548	128	106	P1M100VE•A••010	4289	4221	196	128
P1M100VR•A••025	4638	4548	128	74	P1M100VE•A••025	4317	4227	190	100

## Main data: P1M

Cylinder designation	Cylinder bore area		Piston rod bore area		thread (female)	thread (male)	Total mass		Moving mass		Air consumption	Conn. thread
	mm	cm <sup>2</sup>	mm	cm <sup>2</sup>			at 0 mm stroke	addition per 10 mm stroke	at 0 mm stroke	addition per 10 mm stroke		
P1M012	12	1,13	6	0,28	M3	M6	0,060	0,016	0,010	0,002	0,0139 <sup>1)</sup>	M5
P1M016	16	2,01	8	0,50	M4	M6	0,090	0,022	0,015	0,004	0,0246 <sup>1)</sup>	M5
P1M020	20	3,14	10	0,78	M5	M8	0,150	0,032	0,025	0,006	0,0385 <sup>1)</sup>	M5
P1M025	25	4,91	10	0,78	M6	M10x1,25	0,170	0,034	0,030	0,006	0,0633 <sup>1)</sup>	M5
P1M032	32	8,0	12	1,1	M6	M10x1,25	0,260	0,044	0,050	0,009	0,1050 <sup>1)</sup>	G1/8
P1M040	40	12,6	16	2,0	M6	M12x1,25	0,370	0,060	0,090	0,016	0,1620 <sup>1)</sup>	G1/8
P1M050	50	19,6	20	3,1	M8	M16x1,5	0,570	0,085	0,140	0,025	0,2530 <sup>1)</sup>	G1/8
P1M063	63	31,2	20	3,1	M8	M16x1,5	0,860	0,098	0,220	0,025	0,4140 <sup>1)</sup>	G1/8
P1M080	80	50,3	25	4,9	M10	M20x1,5	1,460	0,146	0,380	0,039	0,6690 <sup>1)</sup>	G1/4
P1M100	100	78,5	25	4,9	M12	M20x1,5	2,390	0,155	0,650	0,039	1,0430 <sup>1)</sup>	G1/4

1) Free air consumption per 10 mm stroke length for a double stroke at 6 bar

## Material specification

Piston rod	Stainless steel, DIN X 10 CrNiS 18 9
Piston rod seal	Polyurethane
Piston rod bearing	Multilayer PTFE/steel
End plates	Anodised aluminium
End cap screws	Zink plated steel
O-ring, internal	Nitrile rubber, NBR
Cylinder barrel	Anodised aluminium
Piston	Aluminium
Piston seal	Nitrile rubber, NBR
Piston bearing	UHMWPE-plastic
Magnet	Plastic-bound magnetic material
Bumpers	Polyurethane
Return spring	Surface-treated steel

## Variants:

### High-temperature version, type G

Piston rod seal	Fluorocarbon rubber, FPM
Piston seal	Fluorocarbon rubber, FPM
O-ring	Fluorocarbon rubber, FPM

## Additional data

Working pressure	max 10 bar
Working temperature	max +80 °C min -20 °C

High-temperature version	max +150 °C min -10 °C
--------------------------	---------------------------

Pre-lubricated, further lubrication is not normally necessary. If additional lubrication is introduced it must be continued.

## Cushioning diagram

Use the diagram below to determine the necessary size of cylinder to provide the requisite cushioning performance. The maximum cushioning performance, as indicated in the diagram, is based on the following assumptions:

- Low load, i.e. low pressure drop across the piston
- Steady-state piston speed

The load is the sum of the internal and external friction, together with any gravity forces. At high relative loading it is recommended that, for a given speed, the load should be reduced by a factor of 2.5, or that, for a given mass, the speed should be reduced by a factor of 1.5. These factors apply in relation to the maximum performance as shown in the diagram.

## Fixed end-cushioning

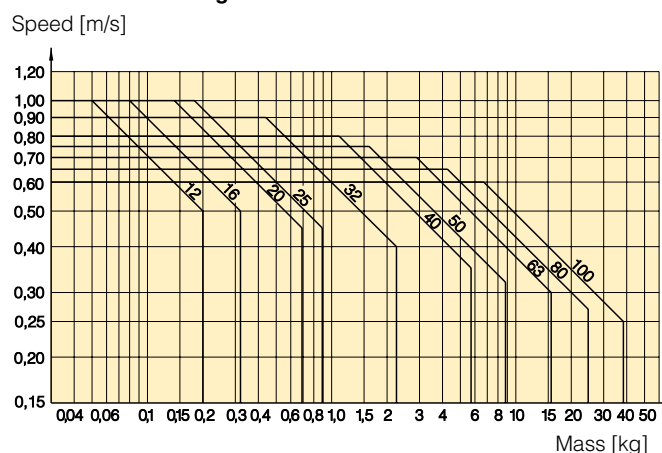

## Working medium, air quality

Working medium	Dry, filtered compressed air to ISO 8573-1 class 3.4.3.
----------------	---

## Recommended air quality for cylinders

For best possible service life and trouble-free operation, ISO 8573-1 quality class 3.4.3 should be used. This means 5 µm filter (standard filter) dew point +3 °C for indoor operation (a lower dew point should be selected for outdoor operation) and oil concentration 1.0 mg oil/m<sup>3</sup>, which is what a standard compressor with a standard filter gives.

## ISO 8573-1 quality classes

Quality class	Pollution particle size (µm)	max concentration (mg/m <sup>3</sup> )	Water max. press. dew point (°C)	Oil max concentration (mg/m <sup>3</sup> )
1	0,1	0,1	-70	0,01
2	1	1	-40	0,1
3	5	5	-20	1,0
4	15	8	+3	5,0
5	40	10	+7	25
6	-	-	+10	-

**Guide for selecting suitable tubing**

The selection of the correct size of tubing is often based on experience, with no great thought to optimizing energy efficiency and cylinder velocity. This is usually acceptable, but making a rough calculation can result in worthwhile economic gains.

**The following is the basic principle:**

1. The primary line to the working valve could be over sized (this does not cause any extra air consumption and consequently does not create any extra costs in operation).
2. The tubes between the valve and the cylinder should, however, be optimized according to the principle that an insufficient bore throttles the flow and thus limits the cylinder speed, while an oversized pipe creates a dead volume which increases the air consumption and filling time.

The chart below is intended to help when selecting the correct size of tube to use between the valve and the cylinder.

**The following prerequisites apply:**

The *cylinder load should be about 50%* of the theoretical force (= normal load). A lower load gives a higher velocity and vice versa. The tube size is selected as a function of the *cylinder bore*, the desired *cylinder velocity* and the *tube length* between the valve and the cylinder.

If you want to use the capacity of the valve to its maximum, and obtain maximum speed, the tubing should be chosen so that they at least correspond with the equivalent restriction diameter (see description below), so that the tubing does not restrict the total flow. This means that a short tubing must have at least the equivalent restriction diameter. If the tubing is longer, choose it from the table below. Straight fittings should be chosen for highest flow rates. (Elbow and banjo fittings cause restriction.)

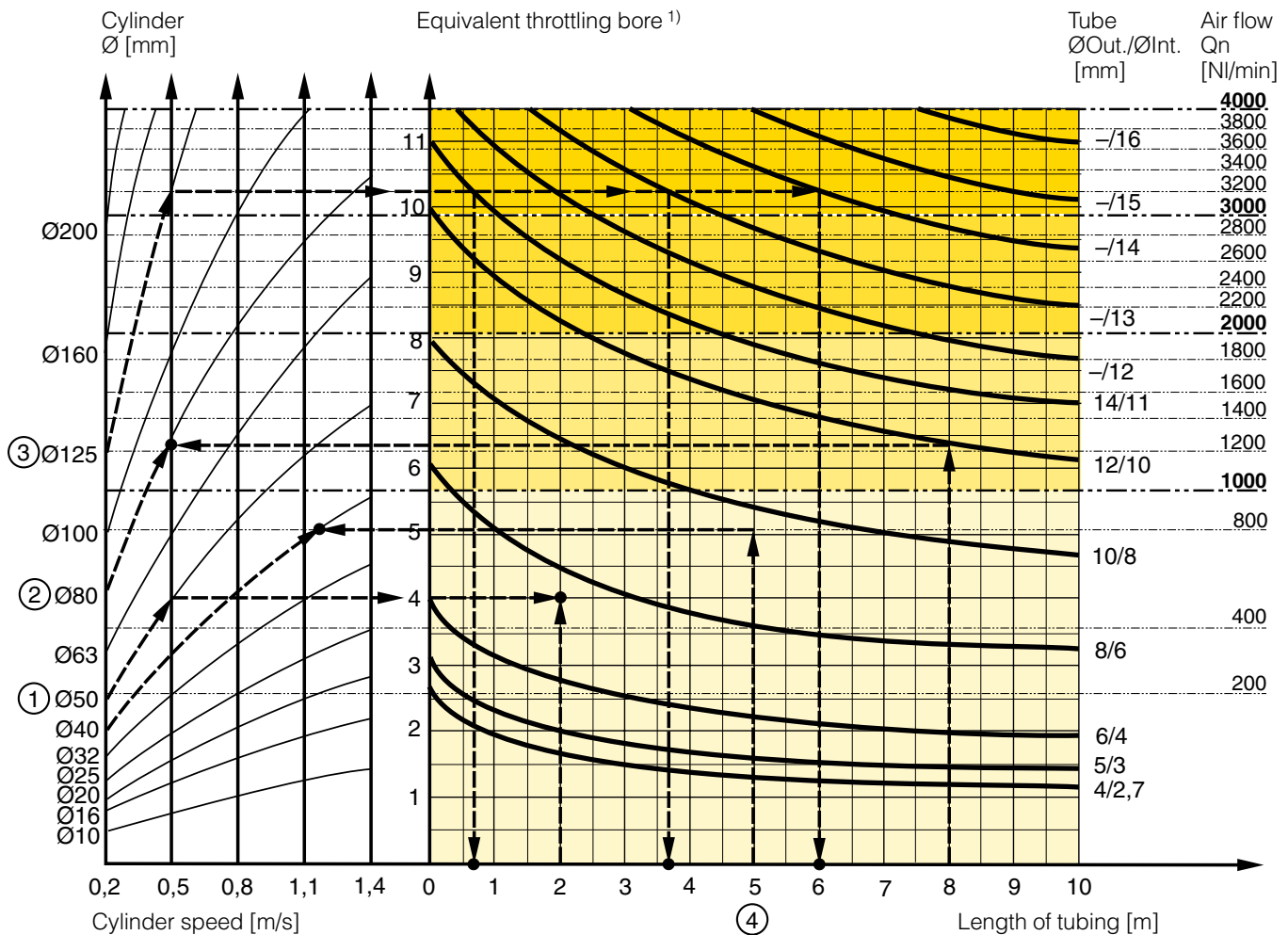

- 1) The “equivalent throttling bore” is a long throttle (for example a tube) or a series of throttles (for example, through a valve) converted to a short throttle which gives a corresponding flow rate. This should not be confused with the “orifice” which is sometimes specified for valves. The value for the orifice does not normally take account of the fact that the valve contains a number of throttles.
- 2) Qn is a measure of the valve flow capacity, with flow measured in litre per minute (l/min) at 6 bar(e) supply pressure and 1 bar pressure drop across the valve.



**Example ①: Which tube diameter should be used?**

A 50 mm bore cylinder is to be operated at 0.5 m/s. The tube length between the valve and cylinder is 2 m. In the diagram we follow the line from 50 mm bore to 0.5 m/s and get an "equivalent throttling bore" of approximately 4 mm. We continue out to the right in the chart and intersect the line for a 2 m tube between the curves for 4 mm (6/4 tube) and 6 mm (8/6 tube). This means that a 6/4 tube throttles the velocity somewhat, while an 8/6 tube is a little too large. We select the 8/6 tube to obtain full cylinder velocity.

**Example ②: What cylinder velocity will be obtained?**

A 80 mm bore cylinder will be used, connected by 8 m 12/10 tube to a P2L-B valve. What cylinder velocity will we get? We refer to the diagram and follow the line from 8 mm tube length up to the curve for 12/10 tube. From there, we go horizontally to the curve for the Ø80 cylinder. We find that the velocity will be about 0.5 m/s.

**Example ③: What is the minimum inner diameter and maximum length of tube?**

For an application a 125 mm bore cylinder will be used. Maximum velocity of piston rod is 0.5 m/s. The cylinder will be controlled by a P2L-D valve. What diameter of tube can be used and what is maximum length of tube. We refer to the diagram. We start at the left side of the diagram cylinder Ø125. We follow the line until the intersection with the velocity line of 0.5 m/s. From here we draw a horizontal line in the diagram. This line shows us we need an equivalent throttling bore of approximately 10 mm. Following this line horizontally we cross a few intersections. These intersections show us the minimum inner diameter (rightside diagram) in combination with the maximum length of tube (bottomside diagram).

For example:

Intersection one: When a tube (14/11) will be used, the maximum length of tube is 0.7 meter.

Intersection two: When a tube (—/13) will be used, the maximum length of tube is 3.7 meter.

Intersection three: When a tube (—/14) will be used, the maximum length of tube is 6 meter.

**Example ④: Determining tube size and cylinder velocity with a particular cylinder and valve?**

For an application using a 40 mm bore cylinder with a valve with  $Q_n=800$  NI/min. The distance between the cylinder and valve has been set to 5 m.

**Tube dimension:** What tube bore should be selected to obtain the maximum cylinder velocity? Start at pipe length 5 m, follow the line up to the intersection with 800 NI/min. Select the next largest tube diameter, in this case Ø10/8 mm.

**Cylinder velocity:** What maximum cylinder velocity will be obtained? Follow the line for 800 NI/min to the left until it intersects with the line for the Ø40 mm cylinder. In this example, the speed is just above 1.1 m/s.

**Valve series with respective flows in NI/minute**

Valve series	Qn in NI/Min
Valvetronic Solstar	33
Interface PS1	100
Adex A05	173
Moduflex size 1, (2 x 3/2)	220
Valvetronic PVL-B 5/3 closed centre, 6 mm push in	290
Moduflex size 1, (4/2)	320
B43 Manual and mechanical	340
Valvetronic PVL-B 2 x 2/3, 6 mm push in	350
Valvetronic PVL-B 5/3 closed centre, G1/8	370
Compact Isomax DX02	385
Valvetronic PVL-B 2 x 3/2 G1/8	440
Valvetronic PVL-B 5/2, 6 mm push in	450
Valvetronic PVL-B 5/3 vented centre, 6 mm push in	450
Moduflex size 2, (2 x 3/2)	450
Flowstar P2V-A	520
Valvetronic PVL-B 5/3 vented centre, G1/8	540
Valvetronic PVL-B 5/2, G1/8	540
Valvetronic PVL-C 2 x 3/2, 8 mm push in	540
Adex A12	560
Valvetronic PVL-C 2 x 3/2 G1/8	570
Compact Isomax DX01	585
VIKING Xtreme P2LAX	660
Valvetronic PVL-C 5/3 closed centre, 8 mm push in	700
Valvetronic PVL-C 5/3 vented centre, G1/4	700
B3-Series	780
Valvetronic PVL-C 5/3 closed centre, G1/4	780
Moduflex size 2, (4/2)	800
Valvetronic PVL-C 5/2, 8 mm push in	840
Valvetronic PVL-C 5/3 vented centre, 8 mm push in	840
Valvetronic PVL-C 5/2, G1/4	840
Flowstar P2V-B	1090
ISOMAX DX1	1150
B53 Manual and mechanical	1160
B4-Series	1170
VIKING Xtreme P2LBX	1290
B5-Series, G1/4	1440
Airline Isolator Valve VE22/23	1470
ISOMAX DX2	2330
VIKING Xtreme P2LCX, G3/8	2460
VIKING Xtreme P2LDX, G1/2	2660
ISOMAX DX3	4050
Airline Isolator Valve VE42/43	5520
Airline Isolator Valve VE82/83	13680

## Dimensions, Double acting standard cylinders

### CAD drawings on the Internet

Our home page [www.parker.com/euro\\_pneumatic](http://www.parker.com/euro_pneumatic) includes the AirCad Drawing Library with 2D and 3D drawings for the main versions.



### Port Position G, J

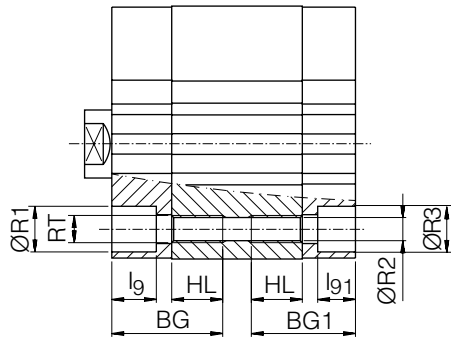

### Port Position H

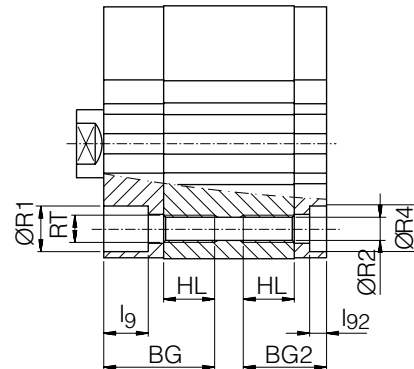

### Port Position G

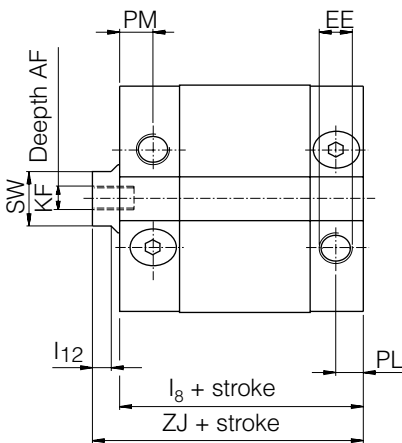

### Port Position H

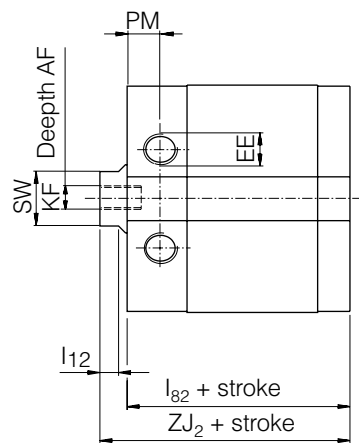

### Port Position J

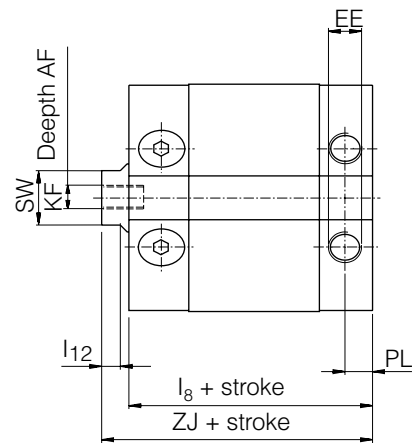

## Dimensions

Cylinder designation	AF mm	BG mm	BG1 mm	BG2 mm	EE	HL mm	l8 mm	l9* mm	l12 mm	l82 mm	l91* mm	l92* mm	KF
P1M012	6	25,5	20,5	15,5	M5	12	40,0	3,5	3,0	35,0	3,5	3,5	M3
P1M016	8	26,0	21,0	15,5	M5	12	41,5	5,5	3,0	36,5	3,0	4,0	M4
P1M020	10	32,5	27,0	22,0	M5	18	42,5	10,5	4,0	37,5	5,0	4,5	M5
P1M025	12	32,5	29,0	23,0	M5	18	44,5	4,1	4,0	38,5	4,1	5,0	M6
P1M032	12	41,5	39,0	31,0	G1/8	24	49,0	4,5	5,0	41,0	4,5	4,0	M6
P1M040	12	41,5	39,5	31,0	G1/8	24	50,5	7,2	5,5	42,5	5,2	3,5	M6
P1M050	12	42,5	40,5	34,5	G1/8	25	51,0	5,2	5,5	44,5	5,2	5,0	M8
P1M063	12	43,5	40,5	35,0	G1/8	25	55,5	6,5	5,5	50,0	6,5	4,0	M8
P1M080	14	51,0	51,0	42,0	G1/4	30	63,5	9,5	6,0	54,5	9,5	8,5	M10
P1M100	16	52,0	52,0	43,5	G1/4	30	72,5	9,5	6,0	64,0	9,5	8,5	M12

Cylinder designation	PL mm	PM mm	R1* mm	R2 mm	R3* mm	R4* mm	RT mm	SW	ZJ mm	ZJ2 mm
P1M012	5,0	8,0	6,0	3,5	6,0	6,0	M4	5	43,5	38,5
P1M016	5,0	9,0	7,5	3,5	6,0	6,0	M4	7	45,0	40,0
P1M020	5,0	9,0	10,5	5,0	9,0	9,0	M6	9	47,0	42,0
P1M025	7,0	9,0	10,5	5,0	9,0	9,0	M6	9	49,5	43,5
P1M032	8,0	10,5	10,5	5,0	9,5	9,5	M6	10	57,0	48,5
P1M040	7,5	9,5	10,5	5,0	10,5	10,5	M6	13	58,5	50,5
P1M050	8,0	10,0	14,5	7,0	14,5	11,0	M8	16	59,0	52,5
P1M063	8,0	11,0	10,5	7,0	10,5	10,5	M8	16	63,5	58,0
P1M080	11,5	11,5	14,0	8,5	14,0	14,0	M10	21	73,5	64,5
P1M100	12,0	12,0	14,0	8,5	14,0	14,0	M10	21	84,5	76,0

Length tolerances ±1 mm    Stroke length tolerances +1,5/0 mm

**Dimensions,  
Single acting and  
High temperature  
variants**

**CAD drawings on the Internet**

Our home page [www.parker.com/euro\\_pneumatic](http://www.parker.com/euro_pneumatic) includes the AirCad Drawing Library with 2D and 3D drawings for the main versions.

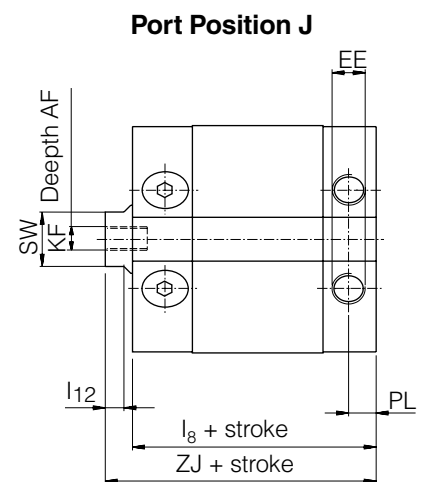
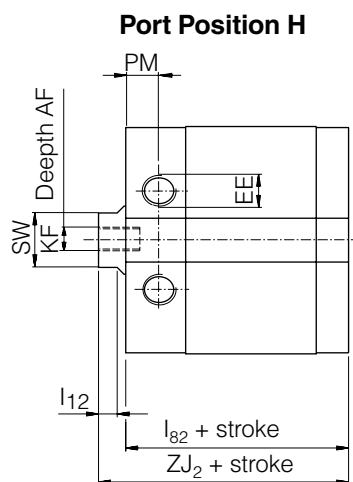
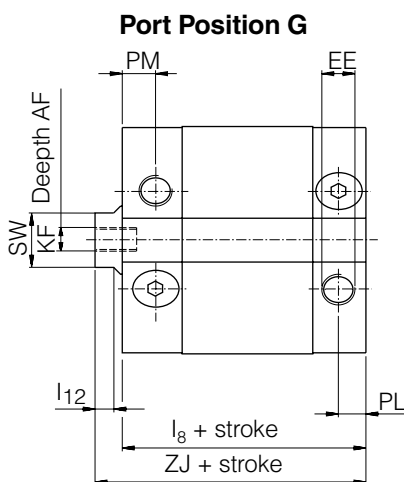
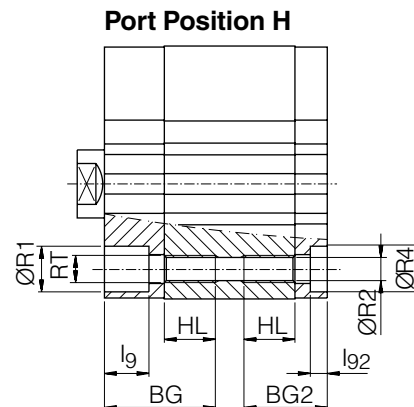
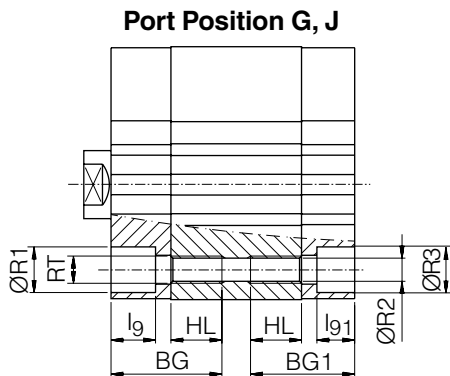

## Dimensions

Cylinder designation	AF mm	BG mm	BG1 mm	BG2 mm	EE mm	HL mm	l8 mm	l9* mm	l12 mm	l82 mm	l91* mm	l92* mm	KF mm
P1M012	6	25,5	20,5	15,5	M5	12	40,0	3,5	3,0	35,0	3,5	3,5	M3
P1M016	8	26,0	21,0	15,5	M5	12	41,5	5,5	3,0	36,5	3,0	4,0	M4
P1M020	10	32,5	27,0	22,0	M5	18	42,5	10,5	4,0	37,5	5,0	4,5	M5
P1M025	12	32,5	29,0	23,0	M5	18	44,5	10,5	4,0	38,5	7,0	5,0	M6
P1M032	12	41,5	39,0	31,0	G1/8	24	49,0	14,5	5,0	41,0	12,5	4,0	M6
P1M040	12	41,5	39,5	31,0	G1/8	24	50,5	14,0	5,5	42,5	12,0	4,0	M6
P1M050	12	42,5	40,5	34,5	G1/8	25	51,0	13,0	5,5	44,5	11,0	5,0	M8
P1M063	12	43,5	40,5	35,0	G1/8	25	55,5	6,5	5,5	50,0	6,5	6,5	M8
P1M080	14	51,0	51,0	42,0	G1/4	30	63,5	9,5	6,0	54,5	9,5	8,5	M10
P1M100	16	52,0	52,0	43,5	G1/4	30	72,5	9,5	6,0	64,0	9,5	8,5	M12

Cylinder designation	PL mm	PM mm	R1* mm	R2 mm	R3* mm	R4* mm	RT mm	SW mm	ZJ mm	ZJ2 mm
P1M012	5,0	8,0	6,0	3,5	6,0	6,0	M4	5	43,5	38,5
P1M016	5,0	9,0	7,5	3,5	6,0	6,0	M4	7	45,0	40,0
P1M020	5,0	9,0	10,5	5,0	9,0	9,0	M6	9	47,0	42,0
P1M025	7,0	9,0	10,5	5,0	9,0	9,0	M6	9	49,5	43,5
P1M032	8,0	10,5	10,5	5,0	10,5	10,5	M6	10	57,0	48,5
P1M040	7,5	9,5	10,5	5,0	10,5	10,5	M6	13	58,5	50,5
P1M050	8,0	10,0	13,5	7,0	13,5	13,5	M8	16	59,0	52,5
P1M063	8,0	11,0	10,5	7,0	10,5	10,5	M8	16	63,5	58,0
P1M080	11,5	11,5	14,0	8,5	14,0	14,0	M10	21	73,5	64,5
P1M100	12,0	12,0	14,0	8,5	14,0	14,0	M10	21	84,5	76,0

Length tolerances  $\pm 1$  mm    Stroke length tolerances  $+1,5/0$  mm

Dimensions

CAD drawings on the Internet

Our home page [www.parker.com/euro\\_pneumatic](http://www.parker.com/euro_pneumatic) includes the AirCad Drawing Library with 2D and 3D drawings for the main versions.



Port Position G, H, J

Bore Ø12 to Ø50 mm

2 mounting holes

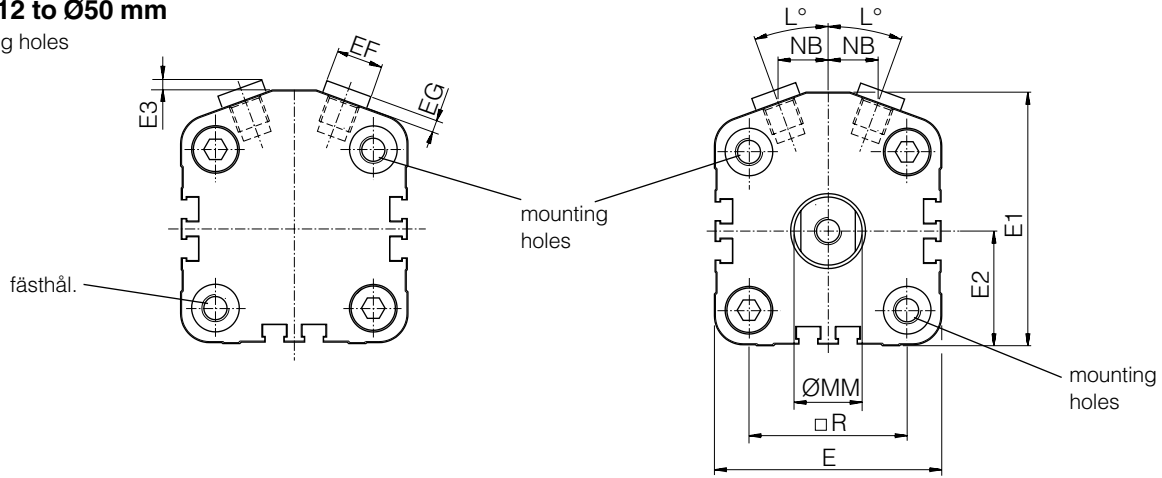

Bore Ø63 to Ø100 mm

4 mounting holes

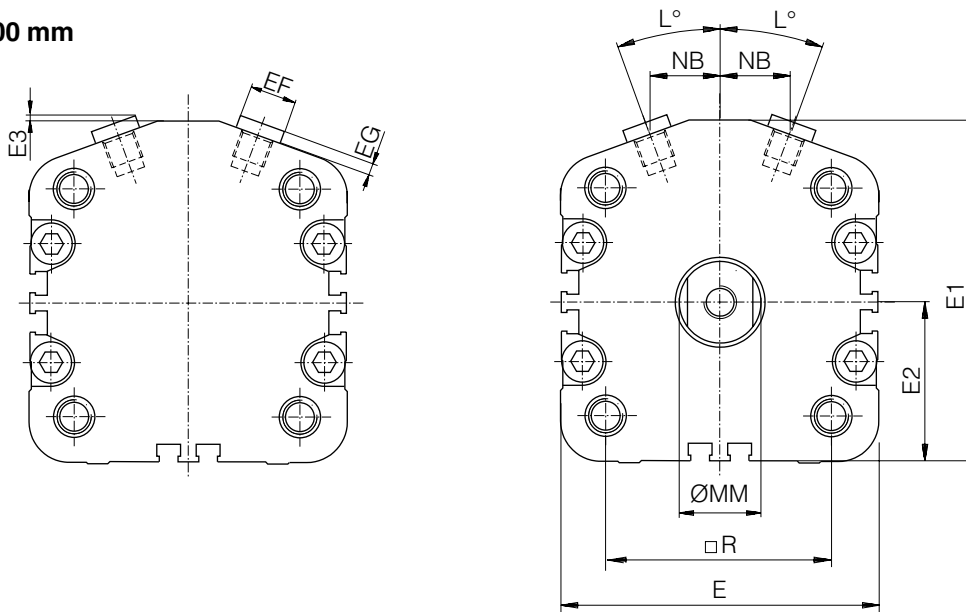

Dimensions

Cylinder designation	E mm	E1 mm	E2 mm	E3 mm	EE mm	EF mm	EG mm	L °	MM mm	NB mm	R mm
P1M 012	27,0	31,0	14,0	-	M5	-	-	26°	6	5,5	15,5
P1M 016	31,5	35,0	16,0	-	M5	-	-	20°	8	6,5	20,0
P1M 020	38,5	42,5	19,5	3,5	M5	7*	4,5	20°	10	7,5	25,5
P1M 025	41,5	45,5	21,0	3,5	M5	7*	4,5	20°	10	8,5	28,0
P1M 032	48,0	56,0	24,0	3,0	G1/8	14	2,5	20°	12	9,5	32,5
P1M 040	56,0	62,5	28,0	3,0	G1/8	14	2,5	20°	16	11,5	38,0
P1M 050	67,0	74,5	33,5	3,0	G1/8	14	2,5	20°	20	14,5	46,5
P1M 063	82,0	86,0	40,5	2,5	G1/8	14	2,5	20°	20	17,5	56,5
P1M 080	98,0	106,5	48,5	2,5	G1/4	17	3,0	20°	25	25,5	72,0
P1M 100	119,0	126,5	59,5	2,5	G1/4	17	3,0	20°	25	31,5	89,0

\*\* Hexagon head screw

## Dimensions

### Cylinder variants

### CAD drawings on the Internet

Our home page [www.parker.com/euro\\_pneumatic](http://www.parker.com/euro_pneumatic) includes the AirCad Drawing. Library with 2D and 3D drawings for the main versions.



### Piston rod thread 8 (external)

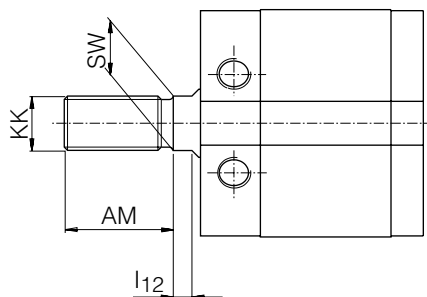

### Cylinder type K (through piston rod)

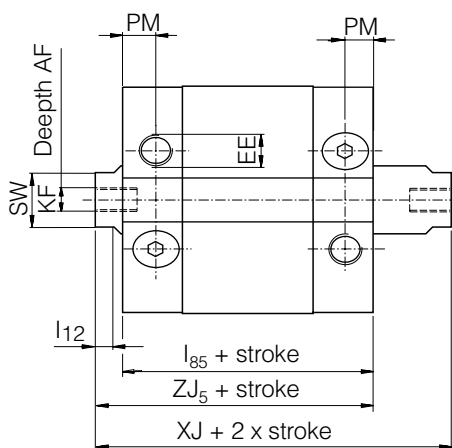

### Cylinder type H (hollow, through piston rod)

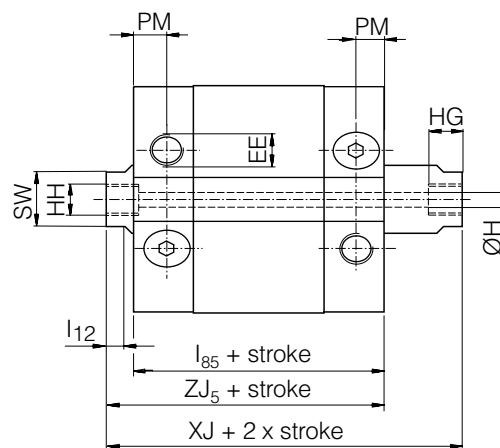

## Dimensions

Cylinder designation	AF mm	AM mm	H* mm	HG mm	HH mm	l12 mm	l85 mm	KF	KK	PM mm	SW mm	XJ mm	ZJ5 mm
P1M 012	6	16	-	-	-	3,0	46,0	M3	M6	8,0	5	54,0	50,0
P1M 016	8	20	-	-	-	3,0	47,5	M4	M6	9,0	7	54,5	51,5
P1M 020	10	22	3	7	M5	4,0	49,5	M5	M8	9,0	9	58,5	54,0
P1M 025	12	22	3	7	M5	4,0	49,5	M6	M10X1,25	9,0	9	60,0	55,0
P1M 032	12	22	3	7	G1/8	5,0	51,5	M6	M10X1,25	10,5	10	67,5	59,5
P1M 040	12	24	4	8	G1/8	5,5	52,5	M6	M12X1,25	9,5	13	69,0	60,5
P1M 050	12	32	5	8	G1/8	5,5	53,0	M8	M16X1,5	10,0	16	69,0	61,0
P1M 063	12	32	5	8	G1/8	5,5	58,5	M8	M16X1,5	11,0	16	75,0	66,5
P1M 080	14	40	6	11	G1/4	6,0	63,5	M10	M20X1,5	11,5	21	84,0	73,5
P1M 100	16	40	6	11	G1/4	6,0	72,5	M12	M20X1,5	12,0	21	97,0	84,5

\* Dimension H only for cylinder H

Length tolerances ±1 mm

Stroke length tolerances +1,5/0 mm



## Order key

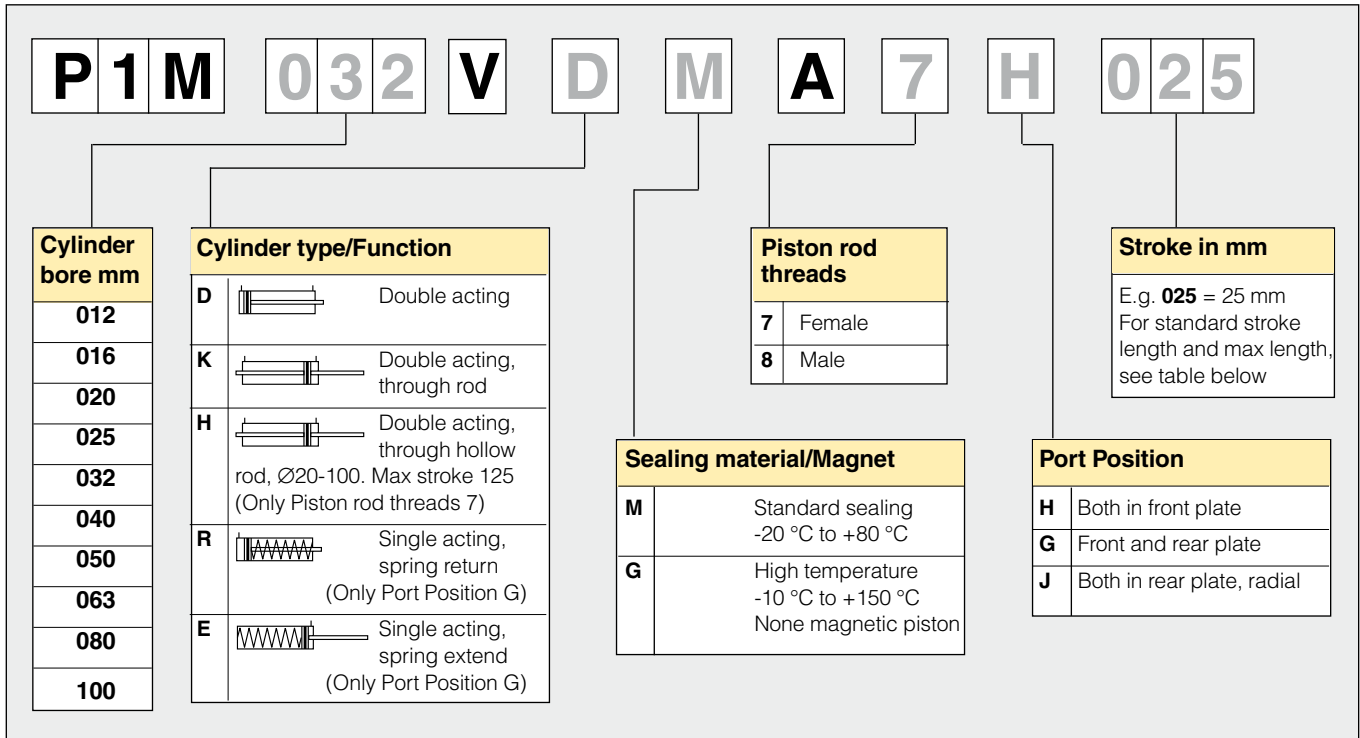

## Standard stroke length in mm

Standard stroke lengths in mm according to ISO 4393. Special strokes up to: see yellow fields in figure below

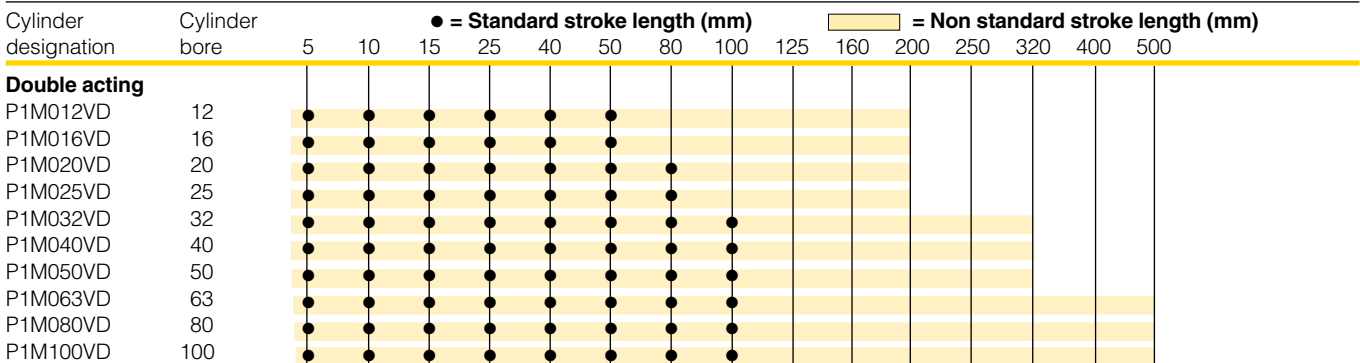

### Single acting, spring return

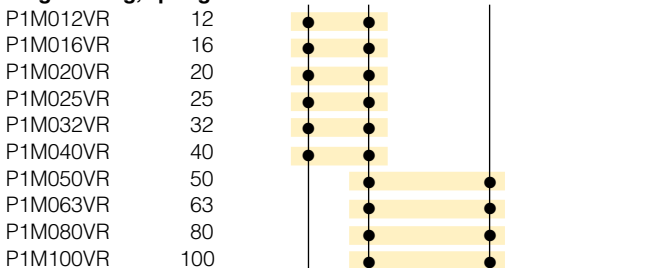

### Single acting, spring extended

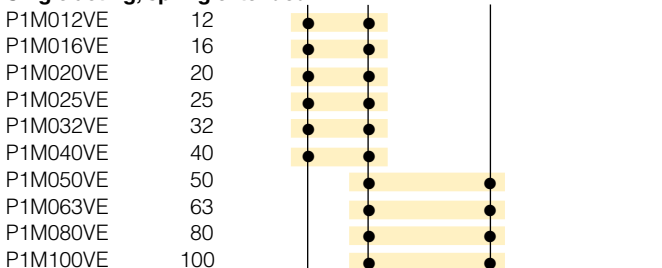

### Port options

P1M cylinders with diameters 25 to 100 mm and port positions G and J are equipped with four ports, two in the front plate and two in the rear plate. Two plugs are then fitted in order to obtain port position G or J.

This allows any user to move these plugs at any time in order to produce the following port options:

- One port each at front and rear, position G
- One port each at front and rear with the plugs a mirror image of position G
- Both ports at rear, position J
- Both ports at front (note that this lengthens the installed dimensions compared with option H, which has very short installed dimensions)

## Double acting

Ports in front and rear plate, female piston rod thread

Ø12 and Ø16 are two-port variants, the rest are four-port variants with two plugs. See also the port options page on the previous page

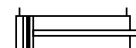

Cyl. bore mm	Stroke mm	Order code	
<b>12</b> M5 thread	5	P1M012VDMA7G005	
	10	P1M012VDMA7G010	
	25	P1M012VDMA7G025	
	40	P1M012VDMA7G040	
	50	P1M012VDMA7G050	
	80	P1M012VDMA7G080	
	100	P1M012VDMA7G100	
	125	P1M012VDMA7G125	
	160	P1M012VDMA7G160	
	200	P1M012VDMA7G200	
<b>16</b> M5 thread	5	P1M016VDMA7G005	
	10	P1M016VDMA7G010	
	25	P1M016VDMA7G025	
	40	P1M016VDMA7G040	
	50	P1M016VDMA7G050	
	80	P1M016VDMA7G080	
	100	P1M016VDMA7G100	
	125	P1M016VDMA7G125	
	160	P1M016VDMA7G160	
	200	P1M016VDMA7G200	
<b>20</b> M5 thread	5	P1M020VDMA7G005	
	10	P1M020VDMA7G010	
	25	P1M020VDMA7G025	
	40	P1M020VDMA7G040	
	50	P1M020VDMA7G050	
	80	P1M020VDMA7G080	
	100	P1M020VDMA7G100	
	125	P1M020VDMA7G125	
	160	P1M020VDMA7G160	
	200	P1M020VDMA7G200	
<b>25</b> M5 thread	5	P1M025VDMA7G005	
	10	P1M025VDMA7G010	
	25	P1M025VDMA7G025	
	40	P1M025VDMA7G040	
	50	P1M025VDMA7G050	
	80	P1M025VDMA7G080	
	100	P1M025VDMA7G100	
	125	P1M025VDMA7G125	
	160	P1M025VDMA7G160	
	200	P1M025VDMA7G200	
	<b>32</b> G1/8 thread	5	P1M032VDMA7G005
		10	P1M032VDMA7G010
25		P1M032VDMA7G025	
40		P1M032VDMA7G040	
50		P1M032VDMA7G050	
80		P1M032VDMA7G080	
100		P1M032VDMA7G100	
125		P1M032VDMA7G125	
160		P1M032VDMA7G160	
200		P1M032VDMA7G200	
250		P1M032VDMA7G250	
320		P1M032VDMA7G320	
<b>40</b> G1/8 thread		5	P1M040VDMA7G005
		10	P1M040VDMA7G010
	25	P1M040VDMA7G025	
	40	P1M040VDMA7G040	
	50	P1M040VDMA7G050	
	80	P1M040VDMA7G080	
	100	P1M040VDMA7G100	
	125	P1M040VDMA7G125	
	160	P1M040VDMA7G160	
	200	P1M040VDMA7G200	
	250	P1M040VDMA7G250	
	320	P1M040VDMA7G320	

Cyl. bore mm	Stroke mm	Order code
<b>50</b> G1/8 thread	5	P1M050VDMA7G005
	10	P1M050VDMA7G010
	25	P1M050VDMA7G025
	40	P1M050VDMA7G040
	50	P1M050VDMA7G050
	80	P1M050VDMA7G080
	100	P1M050VDMA7G100
	125	P1M050VDMA7G125
	160	P1M050VDMA7G160
	200	P1M050VDMA7G200
	250	P1M050VDMA7G250
	320	P1M050VDMA7G320
<b>63</b> G1/8 thread	5	P1M063VDMA7G005
	10	P1M063VDMA7G010
	25	P1M063VDMA7G025
	40	P1M063VDMA7G040
	50	P1M063VDMA7G050
	80	P1M063VDMA7G080
	100	P1M063VDMA7G100
	125	P1M063VDMA7G125
	160	P1M063VDMA7G160
	200	P1M063VDMA7G200
	250	P1M063VDMA7G250
	320	P1M063VDMA7G320
<b>80</b> G1/4 thread	5	P1M080VDMA7G005
	10	P1M080VDMA7G010
	25	P1M080VDMA7G025
	40	P1M080VDMA7G040
	50	P1M080VDMA7G050
	80	P1M080VDMA7G080
	100	P1M080VDMA7G100
	125	P1M080VDMA7G125
	160	P1M080VDMA7G160
	200	P1M080VDMA7G200
	250	P1M080VDMA7G250
	320	P1M080VDMA7G320
<b>100</b> G1/4 thread	5	P1M063VDMA7G005
	10	P1M063VDMA7G010
	25	P1M063VDMA7G025
	40	P1M063VDMA7G040
	50	P1M063VDMA7G050
	80	P1M063VDMA7G080
	100	P1M063VDMA7G100
	125	P1M063VDMA7G125
	160	P1M063VDMA7G160
	200	P1M063VDMA7G200
	250	P1M063VDMA7G250
	320	P1M063VDMA7G320
	400	P1M100VDMA7G400
	500	P1M100VDMA7G500

## Double acting

Both ports in front plate, female piston rod thread

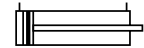

Cyl. bore mm	Stroke mm	Order code
<b>12</b> M5 thread	5	P1M012VDMA7H005
	10	P1M012VDMA7H010
	25	P1M012VDMA7H025
	40	P1M012VDMA7H040
	50	P1M012VDMA7H050
	80	P1M012VDMA7H080
	100	P1M012VDMA7H100
	125	P1M012VDMA7H125
	160	P1M012VDMA7H160
200	P1M012VDMA7H200	
<b>16</b> M5 thread	5	P1M016VDMA7H005
	10	P1M016VDMA7H010
	25	P1M016VDMA7H025
	40	P1M016VDMA7H040
	50	P1M016VDMA7H050
	80	P1M016VDMA7H080
	100	P1M016VDMA7H100
	125	P1M016VDMA7H125
	160	P1M016VDMA7H160
200	P1M016VDMA7H200	
<b>20</b> M5 thread	5	P1M020VDMA7H005
	10	P1M020VDMA7H010
	25	P1M020VDMA7H025
	40	P1M020VDMA7H040
	50	P1M020VDMA7H050
	80	P1M020VDMA7H080
	100	P1M020VDMA7H100
	125	P1M020VDMA7H125
	160	P1M020VDMA7H160
200	P1M020VDMA7H200	
<b>25</b> M5 thread	5	P1M025VDMA7H005
	10	P1M025VDMA7H010
	25	P1M025VDMA7H025
	40	P1M025VDMA7H040
	50	P1M025VDMA7H050
	80	P1M025VDMA7H080
	100	P1M025VDMA7H100
	125	P1M025VDMA7H125
	160	P1M025VDMA7H160
200	P1M025VDMA7H200	
<b>32</b> G1/8 thread	5	P1M032VDMA7H005
	10	P1M032VDMA7H010
	25	P1M032VDMA7H025
	40	P1M032VDMA7H040
	50	P1M032VDMA7H050
	80	P1M032VDMA7H080
	100	P1M032VDMA7H100
	125	P1M032VDMA7H125
	160	P1M032VDMA7H160
	200	P1M032VDMA7H200
	250	P1M032VDMA7H250
	320	P1M032VDMA7H320
	<b>40</b> G1/8 thread	5
10		P1M040VDMA7H010
25		P1M040VDMA7H025
40		P1M040VDMA7H040
50		P1M040VDMA7H050
80		P1M040VDMA7H080
100		P1M040VDMA7H100
125		P1M040VDMA7H125
160		P1M040VDMA7H160
200		P1M040VDMA7H200
250		P1M040VDMA7H250
320		P1M040VDMA7H320

Cyl. bore mm	Stroke mm	Order code
<b>50</b> G1/8 thread	5	P1M050VDMA7H005
	10	P1M050VDMA7H010
	25	P1M050VDMA7H025
	40	P1M050VDMA7H040
	50	P1M050VDMA7H050
	80	P1M050VDMA7H080
	100	P1M050VDMA7H100
	125	P1M050VDMA7H125
	160	P1M050VDMA7H160
	200	P1M050VDMA7H200
	250	P1M050VDMA7H250
	320	P1M050VDMA7H320
	<b>63</b> G1/8 thread	5
10		P1M063VDMA7H010
25		P1M063VDMA7H025
40		P1M063VDMA7H040
50		P1M063VDMA7H050
80		P1M063VDMA7H080
100		P1M063VDMA7H100
125		P1M063VDMA7H125
160		P1M063VDMA7H160
200		P1M063VDMA7H200
250		P1M063VDMA7H250
320		P1M063VDMA7H320
<b>80</b> G1/4 thread		5
	10	P1M080VDMA7H010
	25	P1M080VDMA7H025
	40	P1M080VDMA7H040
	50	P1M080VDMA7H050
	80	P1M080VDMA7H080
	100	P1M080VDMA7H100
	125	P1M080VDMA7H125
	160	P1M080VDMA7H160
	200	P1M080VDMA7H200
	250	P1M080VDMA7H250
	320	P1M080VDMA7H320
	<b>100</b> G1/4 thread	5
10		P1M063VDMA7H010
25		P1M063VDMA7H025
40		P1M063VDMA7H040
50		P1M063VDMA7H050
80		P1M063VDMA7H080
100		P1M063VDMA7H100
125		P1M063VDMA7H125
160		P1M063VDMA7H160
200		P1M063VDMA7H200
250		P1M063VDMA7H250
320		P1M063VDMA7H320
400		P1M100VDMA7H400
500	P1M100VDMA7H500	

**Single acting**

Spring return, female piston rod thread

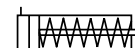

Cyl. bore mm	Stroke mm	Order code
<b>12</b>	5	<b>P1M012VRMA7G005</b>
	10	<b>P1M012VRMA7G010</b>
M5 thread	5	<b>P1M016VRMA7G005</b>
	10	<b>P1M016VRMA7G010</b>
<b>16</b>	5	<b>P1M020VRMA7G005</b>
	10	<b>P1M020VRMA7G010</b>
M5 thread	5	<b>P1M025VRMA7G005</b>
	10	<b>P1M025VRMA7G010</b>
<b>20</b>	5	<b>P1M032VRMA7G005</b>
	10	<b>P1M032VRMA7G010</b>
M5 thread	5	<b>P1M040VRMA7G005</b>
	10	<b>P1M040VRMA7G010</b>
<b>25</b>	5	<b>P1M050VRMA7G005</b>
	10	<b>P1M050VRMA7G010</b>
M5 thread	5	<b>P1M063VRMA7G005</b>
	10	<b>P1M063VRMA7G010</b>
<b>32</b>	5	<b>P1M080VRMA7G005</b>
	10	<b>P1M080VRMA7G010</b>
G1/8 thread	5	<b>P1M063VRMA7G005</b>
	10	<b>P1M063VRMA7G010</b>
<b>40</b>	5	<b>P1M080VRMA7G005</b>
	10	<b>P1M080VRMA7G010</b>
G1/8 thread	5	<b>P1M080VRMA7G005</b>
	10	<b>P1M080VRMA7G010</b>
<b>50</b>	5	<b>P1M063VRMA7G005</b>
	10	<b>P1M063VRMA7G010</b>
G1/8 thread	5	<b>P1M080VRMA7G005</b>
	10	<b>P1M080VRMA7G010</b>
<b>63</b>	5	<b>P1M063VRMA7G005</b>
	10	<b>P1M063VRMA7G010</b>
G1/8 thread	5	<b>P1M080VRMA7G005</b>
	10	<b>P1M080VRMA7G010</b>
<b>80</b>	5	<b>P1M063VRMA7G005</b>
	10	<b>P1M063VRMA7G010</b>
G1/4 thread	5	<b>P1M063VRMA7G005</b>
	10	<b>P1M063VRMA7G010</b>
<b>100</b>	5	<b>P1M063VRMA7G005</b>
	10	<b>P1M063VRMA7G010</b>
G1/4 thread	5	<b>P1M063VRMA7G005</b>
	10	<b>P1M063VRMA7G010</b>

## Cylinder mountings

Type	Description	Cyl. bore Ø mm	Mass kg	Order code
<b>Flange MF1/MF2</b> 	Intended for fixed mounting of cylinder. Flange can be fitted to front- or rear end-plates of cylinder.  Materials Flange: Surface-treated steel, black Mounting screws according to DIN 6912: Zinc-plated steel 8.8  Supplied complete with mounting screws for attachment to cylinder.	12	0,08	<b>P1M-4DMB</b> <b>P1M-4FMB</b> <b>P1M-4HMB</b> <b>P1M-4JMB</b> <b>P1C-4KMB</b> <b>P1C-4LMB</b> <b>P1C-4MMB</b> <b>P1C-4NMB</b> <b>P1C-4PMB</b> <b>P1C-4QMB</b>
		16	0,10	
		20	0,16	
		25	0,20	
		32	0,23	
		40	0,28	
		50	0,53	
		63	0,71	
		80	1,59	
		100	2,19	

Ø32-100 according to ISO MF1/MF2, VDMA, AFNOR

Cyl. bore mm	d1 mm	FB mm	TG1 mm	E mm	R mm	MF mm	TF mm	UF mm	l1 mm	W mm	ZF* mm	ZB* mm	ZF2* mm	ZB2* mm
	H11	H13				JS14	JS14	JS14	-0,5					
12	9,0	4,5	15,5	25	-	5,5	45,0	55	3,0	2,0	44,0	38,5	49,0	43,5
16	11,5	4,5	20,0	30	-	5,5	45,0	55	3,0	2,0	45,5	40,0	50,5	45,0
20	14,0	6,6	25,5	39	-	8,0	50,5	62	4,2	4,5	49,0	41,0	54,0	46,0
25	14,0	6,6	28,0	42	-	8,0	53,0	65	4,2	3,0	51,5	43,5	56,5	49,5
32	30,0	7,0	32,5	45	32	10,0	64,0	80	5,0	2,0	58,5	48,5	67,0	57,0
40	35,0	9,0	38,0	52	36	10,0	72,0	90	5,0	2,0	60,5	50,5	68,5	58,5
50	40,0	9,0	46,5	65	45	12,0	90,0	110	6,5	4,0	64,5	52,5	71,0	59,0
63	45,0	9,0	56,5	75	50	12,0	100,0	120	6,5	4,0	70,0	58,0	75,5	63,5
80	45,0	12,0	72,0	95	63	16,0	126,0	150	8,0	6,0	80,5	64,5	89,5	73,5
100	55,0	14,0	89,0	115	75	16,0	150,0	170	8,0	4,0	92,0	76,0	100,5	84,5

S = Stroke length

\* ZF, ZB for cylinders with both ports in front end (type H)  
ZF2, ZB2 for all other cylinders (type G, J, K)

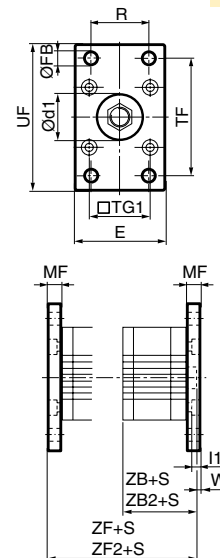

## Angle bracket MS1

Type	Description	Cyl. bore Ø mm	Mass kg	Order code
<b>Angle bracket MS1</b> 	Intended for fixed mounting of cylinder. Angle bracket can be fitted to front- and rear end-plates of cylinder.  Materials Angle bracket: Bore 12-25 mm, Zinc-plated steel Bore 32-50 mm, Surface-treated aluminium, black Bore 63-100 mm, Surface-treated steel, black Mounting screws: according to DIN 912: Zinc-plated steel 8.8  Supplied in pairs with mounting screws for attachment to cylinder.	12	0,02*	<b>P1M-4DMF</b> <b>P1M-4FMF</b> <b>P1M-4HMF</b> <b>P1M-4JMF</b> <b>P1C-4KMZ</b> <b>P1C-4LMZ</b> <b>P1C-4MMZ</b> <b>P1C-4NMF</b> <b>P1C-4PMF</b> <b>P1C-4QMF</b>
		16	0,02*	
		20	0,04*	
		25	0,05*	
		32	0,06*	
		40	0,08*	
		50	0,16*	
		63	0,25*	
		80	0,50*	
		100	0,85*	

\* Weight per item

Ø32-100 according to ISO MS1, VDMA, AFNOR

Cyl. bore mm	AB mm	TG1 mm	E mm	TR mm	AO mm	AU mm	AH mm	I7 mm	AT mm	I9 mm	I8 mm	SA* mm	SA2* mm
	H14			JS14			JS15		JS14				
12	4,5	15,5	44	35	5,5	8,0	17	29,5	2	-	8	51,0	56,0
16	4,5	20,0	48	39	6,0	8,0	19	33,5	2	-	10	52,5	57,5
20	6,6	25,5	62	50	7,5	9,0	24	42,0	3,2	-	12	59,5	64,5
25	6,6	28,0	66	52	7,5	10,5	26	46,0	3,2	-	12	59,5	65,5
32	7,0	32,5	45	32	11,0	24,0	32	54,5	8,0	-	30	88,5	97,0
40	9,0	38,0	52	36	7,0	28,0	36	62,0	8,0	-	35	98,5	106,5
50	9,0	46,5	65	45	13,0	32,0	45	77,5	10,0	-	40	108,5	115,0
63	9,0	56,5	75	50	13,0	32,0	50	35,0	5,5	27,5	-	114,0	119,5
80	12,0	72,0	95	63	14,0	41,0	63	49,0	6,5	40,5	-	136,5	145,5
100	14,0	89,0	115	75	15,0	41,0	71	54,0	6,5	43,5	-	146,0	154,5

S = Stroke length

\* SA for cylinders with both ports in front end (type H)  
\* SA2 for all other cylinders (type G, J, K)

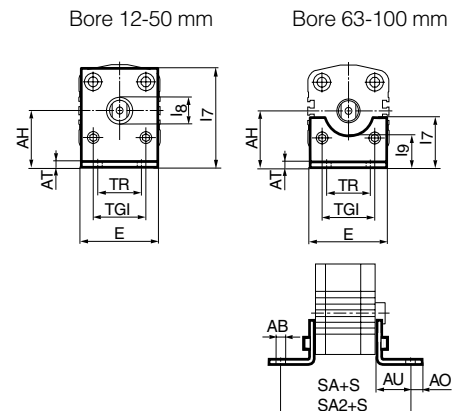



## Cylinder mountings

Type	Description	Cyl. bore Ø mm	Mass kg	Order code
<b>Pivot bracket with rigid bearing</b>	Intended for flexible mounting of cylinder. The pivot bracket can be combined with clevis bracket MP2.  Materials Pivot bracket: Surface-treated aluminium, black Bearing: Sintered oil-bronze bushing	32	0,06	<b>P1C-4KMD</b> <b>P1C-4LMD</b> <b>P1C-4MMD</b> <b>P1C-4NMD</b> <b>P1C-4PMD</b> <b>P1C-4QMD</b>
		40	0,08	
		50	0,15	
		63	0,20	
		80	0,33	
		100	0,49	

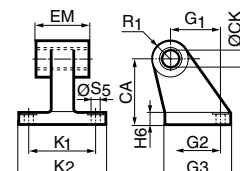

Ø32-100 according to CETOP RP 107 P, VDMA, AFNOR

Cyl. bore mm	CK H9 mm	S5 H13 mm	K1 JS14 mm	K2 mm	G1 JS14 mm	G2 JS14 mm	EM mm	G3 mm	CA mm	H6 mm	R1 mm
32	10	6,6	38	51	21	18	25,5	31	32	8	10
40	12	6,6	41	54	24	22	27,0	35	36	10	11
50	12	9,0	50	65	33	30	31,0	45	45	12	13
63	16	9,0	52	67	37	35	39,0	50	50	12	15
80	16	11,0	66	86	47	40	49,0	60	63	14	15
100	20	11,0	76	96	55	50	59,0	70	71	15	19

## Clevis bracket MP2



Intended for flexible mounting of cylinder. Clevis bracket MP2 can be combined with clevis bracket MP4.

Materials  
Clevis bracket: Surface-treated aluminium, black  
Mounting screws according to DIN 912:  
Zinc-plated steel 8.8  
Pin: surface treated steel

Supplied complete with mounting screws for attachment to cylinder.

12	0,02
16	0,03
20	0,05
25	0,06
32	0,08
40	0,11
50	0,14
63	0,29
80	0,36
100	0,64

**P1M-4DMT**  
**P1M-4FMT**  
**P1M-4HMT**  
**P1M-4JMT**  
**P1C-4KMT**  
**P1C-4LMT**  
**P1C-4MMT**  
**P1C-4NMT**  
**P1C-4PMT**  
**P1C-4QMT**

Ø32-100 according to ISO MP2, VDMA, AFNOR

Cyl. bore mm	E mm	UB h14 mm	CB H14 mm	FL ±0,2 mm	L mm	I2 mm	CD H9 mm	MR mm	XD* mm	XD2* mm
12	27,0	10	5,2	14	7	-	5	6	52,5	57,5
16	31,5	12	6,7	15	10	-	5	6	55,0	60,0
20	38,5	16	8,2	18	12	-	8	9	59,0	65,0
25	41,0	20	10,2	20	14	-	10	10	63,5	69,5
32	45,0	25	12,2	22	16	-	10	10	70,5	79,0
40	52,0	32	15,2	25	18	-	12	12	75,5	83,5
50	65,0	40	20,2	27	22	-	12	12	79,5	86,0
63	75,0	50	25,2	32	27	-	16	16	90,0	95,5
80	95,0	63	32,2	36	32	-	16	16	100,5	109,5
100	115,0	80	42,2	41	37	-	20	20	117,0	125,5

S = Stroke length

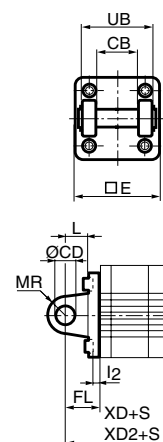

\* XD for cylinders with both ports in front end (type H)  
XD2 for all other cylinders (type G, J, K)

## Cylinder mountings

Type	Description	Cyl. bore Ø mm	Mass kg	Order code
<b>Clevis bracket MP4</b> 	Intended for flexible mounting of cylinder. Clevis bracket MP4 can be combined with clevis bracket MP2.  Materials Clevis bracket: Surface-treated aluminium, black Mounting screws according to DIN 912: Zinc-plated steel 8.8  Supplied complete with mounting screws for attachment to cylinder.	12	0,02	<b>P1M-4DME</b> <b>P1M-4FME</b> <b>P1M-4HME</b> <b>P1M-4JME</b> <b>P1C-4KME</b> <b>P1C-4LME</b> <b>P1C-4MME</b> <b>P1C-4NME</b> <b>P1C-4PME</b> <b>P1C-4QME</b>
		16	0,03	
		20	0,05	
		25	0,07	
		32	0,09	
		40	0,13	
		50	0,17	
		63	0,36	
		80	0,46	
		100	0,83	

Ø32-100 according to ISO MP4, VDMA, AFNOR

Cyl. bore mm	E mm	EW mm	FL mm ±0,2	L mm	I2 mm	CD mm H9	MR mm	XD* mm	XD2* mm
12	27,0	4,7	14	7	-	5	6	52,5	57,5
16	31,5	6,2	15	10	-	5	6	55,0	60,0
20	38,5	7,7	18	12	-	8	9	59,0	65,0
25	41,0	9,7	20	14	-	10	10	63,5	69,5
32	45,0	26,0	22	13	5,5	10	10	70,5	79,0
40	52,0	28,0	25	16	5,5	12	12	75,5	83,5
50	65,0	32,0	27	16	6,5	12	12	79,5	86,0
63	75,0	40,0	32	21	6,5	16	16	90,0	95,5
80	95,0	50,0	36	22	10,0	16	16	100,5	109,5
100	115,0	60,0	41	27	10,0	20	20	117,0	125,5

S = Stroke length

\* XD for cylinders with both ports in front end (type H)  
XD2 for all other cylinders (type G, J, K)

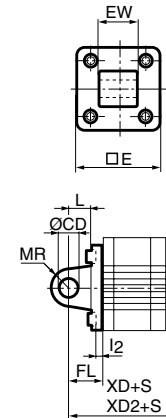

## Clevis bracket GA

	Intended for flexible mounting of cylinder. Clevis bracket GA can be combined with pivot bracket with swivel bearing, swivel eye bracket and swivel rod eye.		32	0,09	<b>P1C-4KMCA</b> <b>P1C-4LMCA</b> <b>P1C-4MMCA</b> <b>P1C-4NMCA</b> <b>P1C-4PMCA</b> <b>P1C-4QMCA</b>
	Materials Clevis bracket: Surface-treated aluminium Pin: Surface hardened steel Locking pin: Spring steel Circlips according to DIN 471: Spring steel Mounting screws acc. to DIN 912: Zinc-plated steel 8.8  Supplied complete with mounting screws for attachment to cylinder.		40	0,13	
			50	0,17	
			63	0,36	
			80	0,58	
			100	0,89	

According to VDMA, AFNOR

Cyl. bore mm	E mm	B2 mm d12	B1 mm H14	T mm	B3 mm	R2 mm	L1 mm	FL mm ±0,2	I2 mm	L mm	CN mm F7	R1 mm	XD* mm	XD2* mm
32	45	34	14	3	3,3	17	11,5	22	5,5	12	10	11	70,5	79,0
40	52	40	16	4	4,3	20	12,0	25	5,5	15	12	13	75,5	83,5
50	65	45	21	4	4,3	22	14,0	27	6,5	17	16	18	79,5	86,0
63	75	51	21	4	4,3	25	14,0	32	6,5	20	16	18	90,0	95,5
80	95	65	25	4	4,3	30	16,0	36	10,0	20	20	22	100,5	109,5
100	115	75	25	4	4,3	32	16,0	41	10,0	25	20	22	117,0	125,5

S = Stroke length

\* XD for cylinders with both ports in front end (type H)  
XD2 for all other cylinders (type G, J, K)

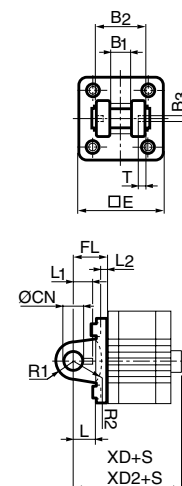

### Stainless steel Pin Set GA

Materials:  
Pin: Stainless steel  
Locking pin: Stainless steel  
Circlips according to DIN 471: Stainless steel

32	0,05	<b>9301054311</b>
40	0,06	<b>9301054312</b>
50	0,07	<b>9301054313</b>
63	0,07	<b>9301054314</b>
80	0,17	<b>9301054315</b>
100	0,31	<b>9301054316</b>

## Cylinder mountings

Type	Description	Cyl. bore Ø mm	Mass kg	Order code
<b>Pivot bracket with swivel bearing</b>	Intended for use together with clevis bracket GA.	32	0,18	<b>P1C-4KMA</b> <b>P1C-4LMA</b> <b>P1C-4MMA</b> <b>P1C-4NMA</b> <b>P1C-4PMA</b> <b>P1C-4QMA</b>
	Material	40	0,25	
	Pivot bracket: Surface-treated steel, black	50	0,47	
	Swivel bearing according to DIN 648K: Hardened steel	63	0,57	
		80	1,05	
		100	1,42	

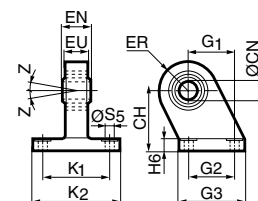
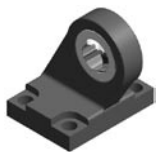

According to VDMA, AFNOR

Cyl. bore mm	CN mm	S5 mm	K1 mm	K2 mm	EU mm	G1 mm	G2 mm	EN mm	G3 mm	CH mm	H6 mm	ER mm	Z mm
32	10	6,6	38	51	10,5	21	18	14	31	32	10	16	4°
40	12	6,6	41	54	12,0	24	22	16	35	36	10	18	4°
50	16	9,0	50	65	15,0	33	30	21	45	45	12	21	4°
63	16	9,0	52	67	15,0	37	35	21	50	50	12	23	4°
80	20	11,0	66	86	18,0	47	40	25	60	63	14	28	4°
100	20	11,0	76	96	18,0	55	50	25	70	71	15	30	4°

## Swivel eye bracket

<b>Swivel eye bracket</b>	Intended for use together with clevis bracket GA	32	0,08	<b>P1C-4KMSA</b> <b>P1C-4LMSA</b> <b>P1C-4MMSA</b> <b>P1C-4NMSA</b> <b>P1C-4PMSA</b> <b>P1C-4QMSA</b>
	Material	40	0,11	
	Bracket: Surface-treated aluminium, black	50	0,20	
	Swivel bearing acc. to DIN 648K: Hardened steel	63	0,27	
		80	0,52	
	Supplied complete with mounting screws for attachment to cylinder.	100	0,72	



According to VDMA, AFNOR

Cyl. bore mm	E mm	B1 mm	B2 mm	EN mm	R1 mm	R2 mm	FL mm	I2 mm	L mm	CN mm	XD* mm	XD2* mm	Z mm
32	45	10,5	38	14	16	14	22	5,5	12	10	70,5	79,0	4°
40	52	12,0	44	16	18	16	25	5,5	15	12	75,5	83,5	4°
50	65	15,0	51	21	21	19	27	6,5	15	16	79,5	86,0	4°
63	75	15,0	56	21	23	22	32	6,5	20	16	90,0	95,5	4°
80	95	18,0	72	25	29	25	36	10,0	20	20	100,5	109,5	4°
100	115	18,0	82	25	31	27	41	10,0	25	20	117,0	125,5	4°

S=Stroke length

\* XD for cylinders with both ports in front end (type H)  
XD2 for all other cylinders (type G, J, K)

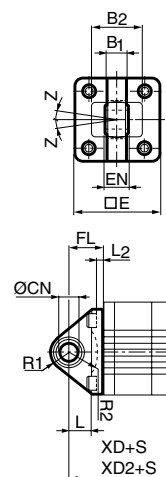

## Cylinder mountings



Type	Description	Cyl. bore Ø mm	Mass kg	Order code
<b>Mounting kit</b>	Mounting kit for back to back mounted cylinders, 3 and 4 position cylinders.  Material: Mounting, Aluminium Mounting screws, Zinc-plated steel 8.8	32	0,060	<b>P1E-6KB0</b> <b>P1E-6LB0</b> <b>P1E-6MB0</b> <b>P1E-6NB0</b> <b>P1E-6PB0</b> <b>P1E-6QB0</b>
		40	0,078	
		50	0,162	
		63	0,194	
		80	0,450	
		100	0,672	

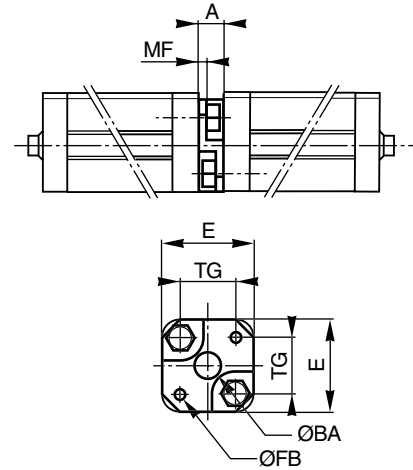

Cyl. bore mm	E mm	TG mm	ØFB mm	MF mm	A mm	ØBA mm
32	50	32,5	6,5	5	16	30
40	60	38,0	6,5	5	16	35
50	66	46,5	8,5	6	20	40
63	80	56,5	8,5	6	20	45
80	100	72,0	10,5	8	25	45
100	118	89,0	10,5	8	25	55



## Cylinder mountings

Type	Description	Cyl. bore Ø mm	Mass kg	Order code
<b>Swivel rod eye</b> 	Swivel rod eye for articulated mounting of cylinder. Swivel rod eye can be combined with clevis bracket GA. Maintenance-free.  Materials Swivel rod eye, nut: Galvanized steel Swivel bearing according to DIN 648K: Hardened steel	12	0,03	<b>P1A-4DRS</b> <b>P1A-4DRS</b> <b>P1A-4HRS</b> <b>P1A-4JRS</b> <b>P1C-4KRS</b> <b>P1C-4LRS</b> <b>P1C-4MRS</b> <b>P1C-4PRS</b> <b>P1C-4PRS</b>
		16	0,03	
		20	0,05	
		25	0,07	
		32	0,08	
		40	0,12	
		50	0,25	
		63	0,25	
		80	0,46	
		100	0,46	
		<b>Stainless steel swivel rod eye</b> 	Stainless-steel swivel rod eye for articulated mounting of cylinder. Swivel rod eye can be combined with clevis bracket GA. Maintenance-free.  Materials Swivel rod eye: Stainless steel Swivel bearing according to DIN 648K: Stainless steel  Use stainless steel nut (see page 25) with stainless steel swivel rod eye.	
16	0,03			
20	0,05			
25	0,08			
32	0,08			
40	0,12			
50	0,25			
63	0,25			
80	0,46			
100	0,46			

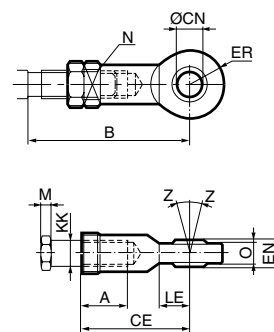

According to ISO 8139

Cyl. bore mm	A mm	B min mm	B max mm	CE mm	CN H9 mm	EN h12 mm	ER mm	KK	LE min mm	M mm	N mm	O mm	Z
12	9	37	40	30	6	9	10	M6	10	3,2	10	6,8	10°
16	9	37	40	30	6	9	10	M6	10	3,2	10	6,8	10°
20	12	44	48	36	8	12	12	M8	12	4,0	13	9,0	12°
25	15	48	55	43	10	14	14	M10x1,25	14	5,0	17	10,5	12°
32	20	48	55	43	10	14	14	M10x1,25	15	5,0	17	10,5	12°
40	22	56	62	50	12	16	16	M12x1,25	17	6,0	19	12,0	12°
50	28	72	80	64	16	21	21	M16x1,5	22	8,0	22	15,0	15°
63	28	72	80	64	16	21	21	M16x1,5	22	8,0	22	15,0	15°
80	33	87	97	77	20	25	25	M20x1,5	26	10,0	32	18,0	15°
100	33	87	97	77	20	25	25	M20x1,5	26	10,0	32	18,0	15°





## Cylinder mountings

Type	Description	Cyl. bore Ø mm	Mass kg	Order code
<b>Clevis</b> 	Clevis for articulated mounting of cylinder.	12	0,02	<b>P1A-4DRC</b>
		16	0,02	<b>P1A-4DRC</b>
	Material	20	0,05	<b>P1A-4HRC</b>
	Clevis, clip, nut: Galvanized steel	25	0,09	<b>P1A-4JRC</b>
	Pin: Hardened steel	32	0,09	<b>P1C-4KRC</b>
		40	0,15	<b>P1C-4LRC</b>
		50	0,35	<b>P1C-4MRC</b>
		63	0,35	<b>P1C-4MRC</b>
		80	0,75	<b>P1C-4PRC</b>
		100	0,75	<b>P1C-4PRC</b>
<b>Stainless steel clevis</b> 	Stainless-steel clevis for articulated mounting of cylinder.	12	0,02	<b>P1S-4DRD</b>
		16	0,02	<b>P1S-4DRD</b>
	Material	20	0,05	<b>P1S-4HRD</b>
	Clevis: Stainless steel	25	0,09	<b>P1S-4JRD</b>
	Pin: Stainless steel	32	0,09	<b>P1S-4JRD</b>
	Circlips according to DIN 471: Stainless steel	40	0,15	<b>P1S-4LRD</b>
		50	0,35	<b>P1S-4MRD</b>
	Use stainless steel nut (see page 25) with stainless steel swivel rod eye.	63	0,35	<b>P1S-4MRD</b>
		80	0,75	<b>P1S-4PRD</b>
		100	0,75	<b>P1S-4PRD</b>

According to ISO 8140

Cyl. bore mm	A mm	B min mm	B max mm	CE mm	CK h11/E9 mm	CL mm	CM mm	ER mm	KK mm	LE mm	M mm	O mm
12	12	28	34	24	6	12	6	7	M6	12	3,2	17,0
16	12	28	34	24	6	12	6	7	M6	12	3,2	17,0
20	16	37	44	32	8	16	8	10	M8	16	4,0	22,0
25	20	45	52	40	10	20	10	12	M10x1,25	20	5,0	28,0
32	20	45	52	40	10	20	10	16	M10x1,25	20	5,0	28,0
40	24	54	60	48	12	24	12	19	M12x1,25	24	6,0	32,0
50	32	72	80	64	16	32	16	25	M16x1,5	32	8,0	41,5
63	32	72	80	64	16	32	16	25	M16x1,5	32	8,0	41,5
80	40	90	100	80	20	40	20	32	M20x1,5	40	10,0	50,0
100	40	90	100	80	20	40	20	32	M20x1,5	40	10,0	50,0

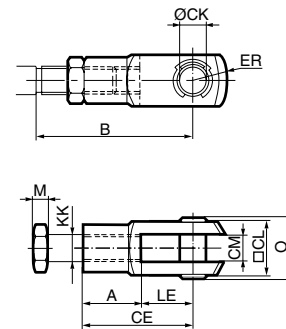

## Cylinder mountings

Type	Description	Cyl. bore Ø mm	Mass kg	Order code
<b>Flexocoupling</b>	Flexocoupling for articulated mounting of piston rod. Flexocoupling is intended to take up axial angle errors within a range of $\pm 4^\circ$ .  Material Flexocoupling, nut: Galvanized steel Socket: Hardened steel	32	0,21	<b>P1C-4KRF</b> <b>P1C-4LRF</b> <b>P1C-4MRF</b> <b>P1C-4MRF</b> <b>P1C-4PRF</b> <b>P1C-4PRF</b>
		40	0,22	
		50	0,67	
		63	0,67	
		80	0,72	
		100	0,72	



Supplied complete with galvanized adjustment nut.

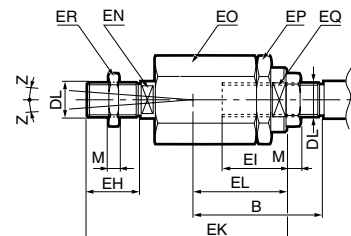

Cyl. bore mm	B min mm	B max mm	DL	EH	EI	EK	EL	EN	EO	EP	EQ	M	Z
32	36	43	M10x1,25	20	23	70	31	12	30	30	19	5	4°
40	37	43	M12x1,25	23	23	67	31	12	30	30	19	6	4°
50	53	61	M16x1,5	40	32	112	45	19	41	41	30	8	4°
63	53	61	M16x1,5	40	32	112	45	19	41	41	30	8	4°
80	57	67	M20x1,5	39	42	122	56	19	41	41	30	10	4°
100	57	67	M20x1,5	39	42	122	56	19	41	41	30	10	4°

Nut	Intended for fixed mounting of accessories to the piston rod.	12	0,002	<b>0261210800</b>
	Material: Galvanized steel  (Cylinders supplied with galvanized nut)	16	0,002	<b>0261210800</b>
		20	0,005	<b>0261211000</b>
		25	0,007	<b>9128985601</b>
		32	0,007	<b>9128985601</b>
		40	0,010	<b>0261109910</b>
		50	0,021	<b>9128985603</b>
		63	0,021	<b>9128985603</b>
		80	0,040	<b>0261109911</b>
		100	0,040	<b>0261109911</b>

Stainless steel nut	Intended for fixed mounting of accessories to the piston rod.	12	0,002	<b>9127385122</b>
	Material: Stainless steel A2	16	0,002	<b>9127385122</b>
		20	0,005	<b>9127385123</b>
		25	0,007	<b>9126725404</b>
		32	0,007	<b>9126725404</b>
		40	0,010	<b>9126725405</b>
		50	0,021	<b>9126725406</b>
		63	0,021	<b>9126725406</b>
		80	0,040	<b>0261109921</b>
		100	0,040	<b>0261109921</b>

According to DIN 439 B

Cyl. bore mm	d	M	S
12	M6	3,2	10
16	M6	3,2	10
20	M8	4,0	13
25	M10x1,25	5,0	17
32	M10x1,25	5,0	17
40	M12x1,25	6,0	19
50	M16x1,5	8,0	24
63	M16x1,5	8,0	24
80	M20x1,5	10,0	30
100	M20x1,5	10,0	30

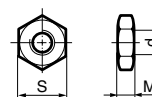

## Our global series of sensors

This series of sensors is already being used or will be used in all future ranges in our global product programme involving cylinders/actuators. The sensors have small installation dimensions and either fit into the groove in the case profile or, as shown here, are fastened to the cylinder using a special attachment.

You can choose from electronic or reed sensors with a range of cable lengths fitted with 8 mm or M12 terminals.



## Electronic sensors

The new electronic sensors are "Solid State", i.e. they have no moving parts at all. They are provided with short-circuit protection and transient protection as standard. The built-in electronics make the sensors suitable for applications with high on and off switching frequency, and where very long service life is required.

### Technical data

Design	GMR (Giant Magnetic Resistance) magneto-resistive function
Installation	Sensor mounting P8S-TMC01
Outputs	PNP, normally open (also available in NPN design, normally closed, on request)
Voltage range	10-30 VDC 10-18 V DC, ATEX sensor
Ripple	max 10%
Voltage drop	max 2,5 V
Load current	max 100 mA
Internal consumption	max 10 mA
Actuating distance	min 9 mm
Hysteresis	max 1,5 mm
Repeatability accuracy	max 0,2 mm
On/off switching frequency	max 5 kHz
On switching time	max 2 ms
Off switching time	max 2 ms
Encapsulation	IP 67 (EN 60529)
Temperature range	-25 °C to +75 °C -20 °C to +45 °C, ATEX sensor
Indication	LED, yellow
Material housing	PA 12
Material screw	Stainless steel
Cable	PVC or PUR 3x0.25 mm <sup>2</sup> see order code respectively

## Reed sensors

The sensors are based on proven reed switches, which offer reliable function in many applications. Simple installation, a protected position on the cylinder and clear LED indication are important advantages of this range of sensors.

### Technical data

Design	Reed element
Mounting	Sensor mounting P8S-TMC01
Output	Normally open , or normally closed
Voltage range	10-30 V AC/DC or 10-120 V AC/DC 24-230 V AC/DC
Load current	max 500 mA for 10-30 V or max 100 mA for 10-120 V max 30 mA for 24-230 V
Breaking power (resistive)	max 6 W/VA
Actuating distance	min 9 mm
Hysteresis	max 1,5 mm
Repeatability accuracy	0,2 mm
On/off switching frequency	max 400 Hz
On switching time	max 1,5 ms
Off switching time	max 0,5 ms
Encapsulation	IP 67 (EN 60529)
Temperature range	-25 °C to +75 °C
Indication	LED, yellow
Material housing	PA12
Material screw	Stainless steel
Cable	PVC or PUR 3x0.14 mm <sup>2</sup> see order code respectively

## Electronic sensors

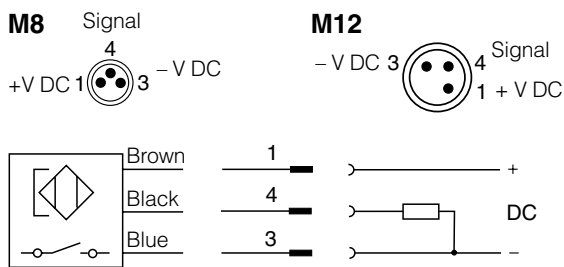

## Reed sensors

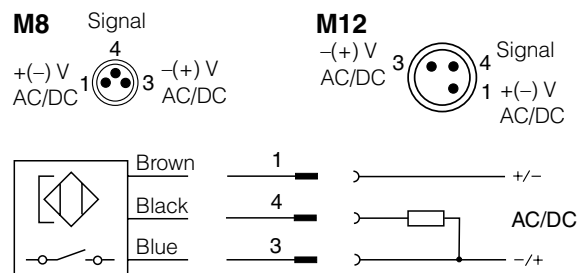

### P8S-GCFPX

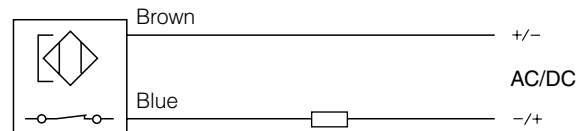

### P8S-GRFLX / P8S-GRFLX2

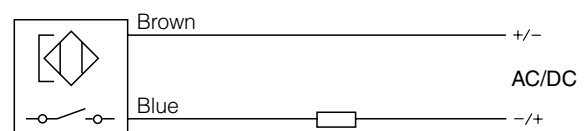

## Dimensions

### Sensors

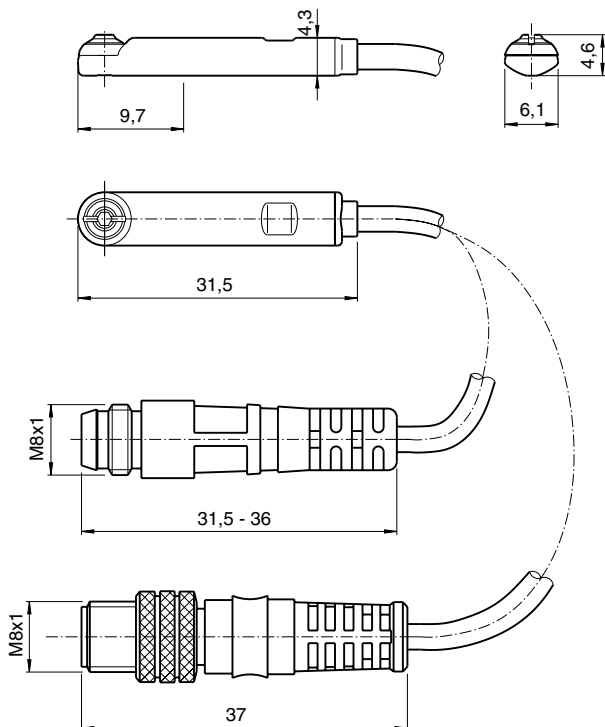

## Ordering data

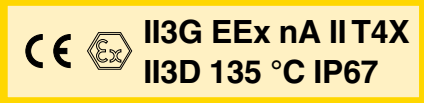
Output/function	Cable/connector	Weight kg	Order code
<b>Electronic sensors , 10-30 V DC</b>			
PNP type, normally open	0,27 m PUR-cable and 8 mm snap-in male connector	0,007	<b>P8S-GPSHX</b>
PNP type, normally open	1,0 m PUR-cable and 8 mm snap-in male connector	0,013	<b>P8S-GPSCX</b>
PNP type, normally open	1,0 m PUR-cable and M8 screw male connector	0,013	<b>P8S-GPCCX</b>
PNP type, normally open	0,27 m PUR-cable and M12 screw male connector	0,015	<b>P8S-GPMHX</b>
PNP type, normally open	3 m PVC-cable without connector	0,030	<b>P8S-GPFLX</b>
PNP type, normally open	10 m PVC-cable without connector	0,110	<b>P8S-GPFTX</b>
<b>Electronic sensor 18-30 V DC</b>			
<b>ATEX-certified</b>			
			
Type PNP , normally open	3 m PVC-cable without connector	0,030	<b>P8S-GPFLX/EX</b>
<b>Reed sensors , 10-30 V AC/DC</b>			
Normally open	0,27 m PUR-cable and 8 mm snap-in male connector	0,007	<b>P8S-GSSHX</b>
Normally open	1,0 m PUR-cable and 8 mm snap-in male connector	0,013	<b>P8S-GSSCX</b>
Normally open	1,0 m PUR-cable and M8 male connector	0,013	<b>P8S-GSCCX</b>
Normally open	0,27 m PUR-cable and M12 screw male connector	0,015	<b>P8S-GSMHX</b>
Normally open	1,0 m PUR-cable and M12 screw male connector	0,023	<b>P8S-GSMCX</b>
Normally open	3 m PVC-cable without connector	0,030	<b>P8S-GSFLX</b>
Normally open	10 m PVC-cable without connector	0,110	<b>P8S-GSFTX</b>
Normally closed	5m PVC-cable without connector <sup>1)</sup>	0,050	<b>P8S-GCFPX</b>
<b>Reed sensors, 10-120 V AC/DC</b>			
Normally open	3 m PVC-cable without connector	0,030	<b>P8S-GRFLX</b>
<b>Reed sensorer, 24-230 V AC/DC</b>			
Normally open	3 m PVC-cable without connector	0,030	<b>P8S-GRFLX2</b>

1) Without LED



### Sensors for special applications

Sensors for applications where the short installation length and the 90 degree cable outlet are important factors. This type of sensor is an good alternative if a cylinder has a short stroke or tight installation.

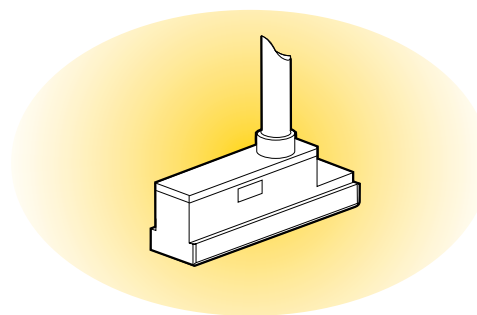

#### Reed switch sensors

The reed switch sensors incorporate a well-proven, universal-voltage, compact reed switch element, making them suitable for a wide range of applications. They can work with electronic control systems or conventional relay systems. No environment is too severe.

#### Technical data

Design	Reed
Output	Making
Voltage range	10 to 120 VAC/VDC
Max permissible ripple	10%
Max voltage drop	3 V
Max load current	100 mA
Max breaking power (resistive)	10 W
Min actuating distance	5 mm
Hysteresis	≤1,0 mm
Repeatability accuracy	≤0,2 mm
Max on/off switching frequency	400 Hz
Max on/off switching time	1 ms
Encapsulation	IP 67
Temperature range	-25 °C to +75 °C
Indication	LED, yellow
Shock resistance	30 g
Material, housing	PA 12
Material, mould	Epoxy
Cable	PVC 3x0,14 mm <sup>2</sup>
Cable incl. female part connector	PVC 3x0,14 mm <sup>2</sup>
Mounting	T slot

#### Electronic sensors

These sensors are of solid-state type, with no moving parts. Short-circuit and transient protection is incorporated as standard. The integral electronics make these sensors suitable for applications with very high switching frequencies.

#### Technical data

Design	Hall element
Output	PNP resp. NPN, N.O.
Voltage range	10-30 VDC
Max permissible ripple	10%
Max voltage drop	≤2 V
Max load current	150 mA
Max breaking power (resistive)	6 W
Internal consumption	15 mA
Min actuating distance	5 mm
Hysteresis	≤1,5 mm
Repeatability accuracy	≤0,2 mm
Max on/off switching frequency	50 Hz
P8S-SPELXD, SPETXD, SPTHXD	5 kHz
Others	5 kHz
Max on/off switching time	0,8/3,0 ms
Encapsulation	IP 67
Temperature range	-25 °C to +75 °C
Indication	LED, yellow
Shock resistance	30 g
Material, housing	PA 12
Material, mould	Epoxy
Cable	PVC 3x0,14 mm <sup>2</sup>
Cable incl. female part connector	PVC 3x0,14 mm <sup>2</sup>
Connector	Diam. 8 mm snap on
Mounting	T slot

#### Ordering data

Output	Cable connection	Cable length	Weight kg	Order code
<b>Reed sensors</b>				
making	90°	3,0 m	0,030	<b>P8S-SRELX</b>
making	90°	10,0 m	0,110	<b>P8S-SRETX</b>
making	90°	0,3 m*	0,005	<b>P8S-SRTHX</b>

\*) Cable shall be ordered separately.

#### Ordering data

Output	Cable connection	Cable length	Weight kg	Order code
<b>Electronic sensors</b>				
PNP, N.O.	90°	3,0 m	0,030	<b>P8S-SPELXD</b>
PNP, N.O.	90°	10,0 m	0,110	<b>P8S-SPETXD</b>
PNP, N.O.	90°	0,3 m*	0,005	<b>P8S-SPTHXD</b>

Dimensions

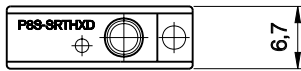
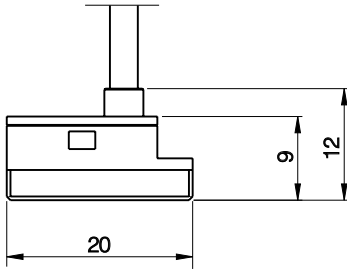
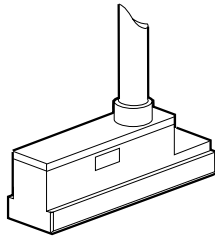

Reed sensor symbol

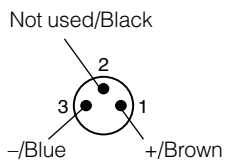
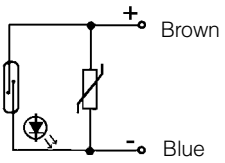

Electronic sensor symbol

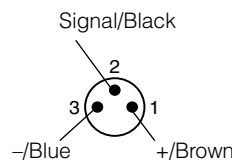
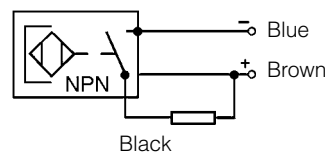
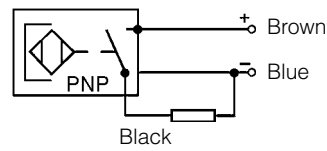

## Connecting cables with one connector

The cables have an integral snap-in female connector.



Type of cable	Cable/connector	Weight kg	Order code
<b>Cables for sensors, complete with one female connector</b>			
Cable, Flex PVC	3 m, 8 mm Snap-in connector	0,07	<b>9126344341</b>
Cable, Flex PVC	10 m, 8 mm Snap-in connector	0,21	<b>9126344342</b>
Cable, Super Flex PVC	3 m, 8 mm Snap-in connector	0,07	<b>9126344343</b>
Cable, Super Flex PVC	10 m, 8 mm Snap-in connector	0,21	<b>9126344344</b>
Cable, Polyurethane	3 m, 8 mm Snap-in connector	0,01	<b>9126344345</b>
Cable, Polyurethane	10 m, 8 mm Snap-in connector	0,20	<b>9126344346</b>
Cable, Polyurethane	5 m, M12 screw connector	0,07	<b>9126344348</b>
Cable, Polyurethane	10 m, M12 screw connector	0,20	<b>9126344349</b>

## Male connectors for connecting cables

Cable connectors for producing your own connecting cables. The connectors can be quickly attached to the cable without special tools. Only the outer sheath of the cable is removed. The connectors are available for M8 and M12 screw connectors and meet protection class IP 65.



Connector	Weight kg	Order code
M8 screw connector	0,017	<b>P8SCS0803J</b>
M12 screw connector	0,022	<b>P8SCS1204J</b>

## Ready to use connecting cables with connectors at each end

As accessories the system comprises a large number of different cables in order to meet all requirements that may arise and to make the installation simple, fast and reliable.

Cables with moulded 8 mm snap-in round contacts in both ends. The cables are available in two types, one with a straight male and female connectors respectively, and one with a straight 3-pole male connector in one end and an angled 3-pole female connector in the other end.



### Technical data

#### Contacts

Moulded 8 mm snap-in male/female contacts.  
Enclosure IP67

#### Cable

Conductor 3x0,25 mm<sup>2</sup> (32x0,10 mm<sup>2</sup>)  
Sheath PVC/PUR  
Colour Black

Cables with straight 3-pole male and female connectors respectively.

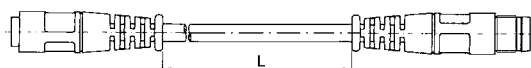

Cables with a straight 3-pole male connector in one end and an angled 3-pole female connector in the other end.

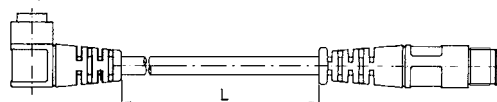

Designation	Weight kg	Order code	Designation	Weight kg	Order code
Cable with straight contacts, 0,2 m	0,02	<b>9121717014</b>	Cable with straight and angled connectors, 0,2 m	0,02	<b>9121717022</b>
Cable with straight contacts, 0,3 m	0,02	<b>9121717015</b>	Cable with straight and angled connectors, 0,3 m	0,02	<b>9121717023</b>
Cable with straight contacts, 0,5 m	0,03	<b>9121717016</b>	Cable with straight and angled connectors, 0,5 m	0,03	<b>9121717024</b>
Cable with straight contacts, 1,0 m	0,03	<b>9121717017</b>	Cable with straight and angled connectors, 1,0 m	0,03	<b>9121717025</b>
Cable with straight contacts, 2,0 m	0,05	<b>9121717018</b>	Cable with straight and angled connectors, 2,0 m	0,05	<b>9121717026</b>
Cable with straight contacts, 3,0 m	0,07	<b>9121717019</b>	Cable with straight and angled connectors, 3,0 m	0,07	<b>9121717027</b>
Cable with straight contacts, 5,0 m	0,12	<b>9121717020</b>	Cable with straight and angled connectors, 5,0 m	0,12	<b>9121717028</b>
Cable with straight contacts, 10 m	0,23	<b>9121717021</b>	Cable with straight and angled connectors, 10 m	0,23	<b>9121717029</b>

## Connection block Valvetronic 110

The Valvetronic 110 is a connection block that can be used for collecting signals from sensors at various points on a machine and connecting them to the control system via a multicore cable. Valvetronic 110 can also be used for central connection of the multi-core cable to the outputs of a control system, and can be laid to a machine where the output signals can be connected. The connection block has ten 8 mm snap-in circular connectors and a multi-core cable which is available in lengths of 3 or 10 m. The connections on the block are numbered from 1 to 10. Blanking plugs are available for unused connections, as labels for marking the connections of each block.



### Technical data

#### Connections:

Ten 3-pole numbered 8 mm round snap-in female contacts

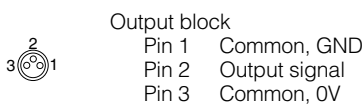
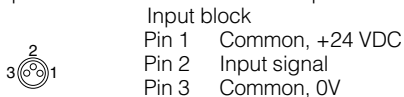

#### Electrical data:

Voltage 24 VDC (max. 60 V AC/75 V DC)  
 Insulation group according to DIN 0110 class C  
 Load max. 1 A per connection total max. 3 A

#### Cable:

Length 3 m or 10 m  
 Type of cable LifYY11Y  
 Conductor 12  
 Area 0.34 mm<sup>2</sup>  
 Colour marking According to DIN 47 100

#### Mechanical data

Enclosure IP 67, DIN 40050 with fitted contacts and/or blanking plugs.  
 Temperature -20 °C to +70 °C

#### Material

Body PA 6,6 VD according to UL 94  
 Contact holder PBTP  
 Snap-in ring LDPE  
 Moulding mass Epoxy  
 Seal NBR  
 Screws Plated steel

#### Industrial durability

Good chemical and oil resistance. Tests should be performed in aggressive environments.

### Ordering data

Designation	Weight kg	Order code
Connection block Valvetronic 110 with 3 m cable	0,32	<b>9121719001</b>
Connection block Valvetronic 110 with 10 m cable	0,95	<b>9121719002</b>
Blanking plugs (pack of 10) Use blanking plugs to close unused connections.	0,02	<b>9121719003</b>
Labels (pack of 10) White labels to insert in grooves on the side of the connection	0,02	<b>9121719004</b>

### Dimensions and wiring diagrams

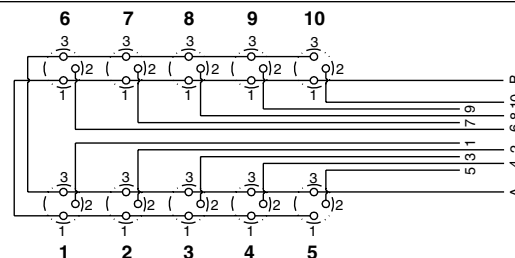
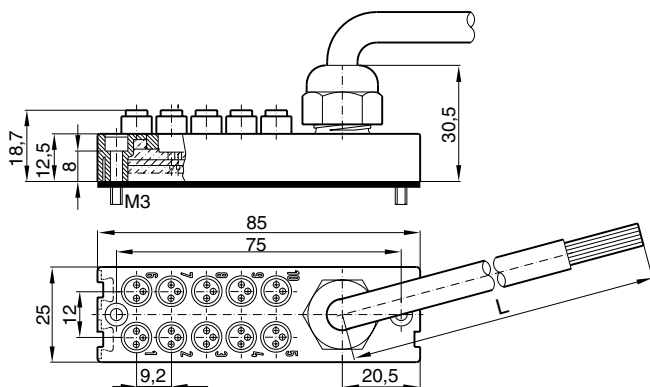

Conductor	Colour	Input	Output
1	Pink	Signal 1	Signal 1
2	Grey	Signal 2	Signal 2
3	Yellow	Signal 3	Signal 3
4	Green	Signal 4	Signal 4
5	White	Signal 5	Signal 5
6	Red	Signal 6	Signal 6
7	Black	Signal 7	Signal 7
8	Violet	Signal 8	Signal 8
9	Grey-Pink	Signal 9	Signal 9
10	Red-Blue	Signal 10	Signal 10
A	Blue	0 V	0 V
B	Brown	+24 V	PE

## Seal kits for P1M

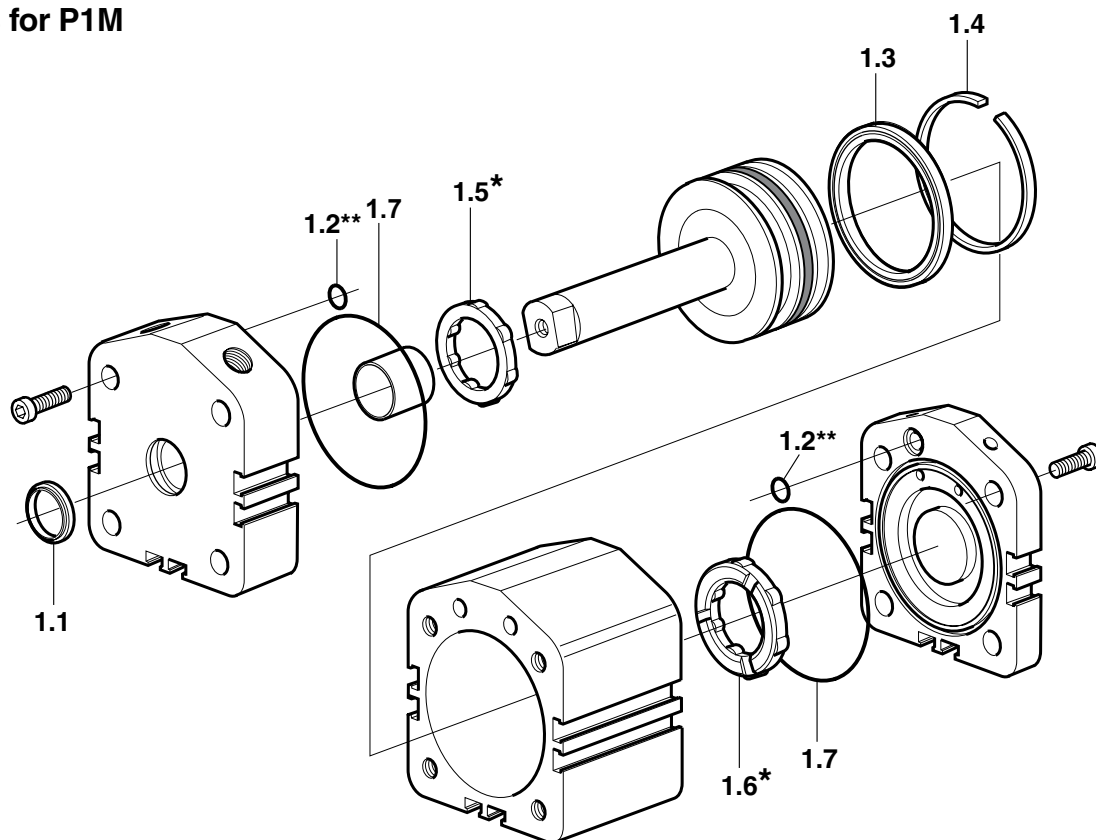

### Seal kits for P1M

No	Qty	Part
1.1	1	Scraper ring/Piston rod seal
1.2	2	O-ring
1.3	1	Piston seals
1.4	1	Piston bearing
1.5	1	Front end bumper
1.6	1	Rear end bumper
1.7	2	O-ring

Material specification, see page 5

\* Bumpers 1.5 and 1.6 not valid for high-temperature version, type G.

\*\* Quantity and design vary, depending on the cylinder variant and model.

### Seal kits for complete P1M cylinder

Cyl. bore mm	Option	
	Standard	High Temp
12	<b>P1M-6DRN</b>	<b>P1M-6DRV</b>
16	<b>P1M-6FRN</b>	<b>P1M-6FRV</b>
20	<b>P1M-6HRN</b>	<b>P1M-6HRV</b>
25	<b>P1M-6JRN</b>	<b>P1M-6JRV</b>
32	<b>P1M-6KRN</b>	<b>P1M-6KRV</b>
40	<b>P1M-6LRN</b>	<b>P1M-6LRV</b>
50	<b>P1M-6MRN</b>	<b>P1M-6MRV</b>
63	<b>P1M-6NRN</b>	<b>P1M-6NRV</b>
80	<b>P1M-6PRN</b>	<b>P1M-6PRV</b>
100	<b>P1M-6QRN</b>	<b>P1M-6QRV</b>

### Grease for P1M



Weight g	Option	
	Standard	High Temp
30	<b>9127394541</b>	<b>9127394521</b>







# Sales Offices

**AE – United Arab Emirates,**  
Abu Dhabi  
Tel: +971 2 67 88 587

**AR – Argentina,** Buenos Aires  
Tel: +54 3327 44 4129

**AT – Austria,** Wiener Neustadt  
Tel: +43 (0)2622 23501-0

**AT – Austria,** Wiener Neustadt  
(Eastern Europe)  
Tel: +43 (0)2622 23501 970

**AU – Australia,** Castle Hill  
Tel: +61 (0)2-9634 7777

**AZ – Azerbaijan,** Baku  
Tel: +994 50 2233 458

**BE – Belgium,** Nivelles  
Tel: +32 (0)67 280 900

**BR – Brazil,** Cachoeirinha RS  
Tel: +55 51 3470 9144

**BY – Belarus,** Minsk  
Tel: +375 17 209 9399

**CA – Canada,** Milton, Ontario  
Tel: +1 905 693 3000

**CH – Switzerland**  
See Germany

**CN – China,** Shanghai  
Tel: +86 21 5031 2525

**CN – China,** Beijing  
Tel: +86 10 6561 0520

**CZ – Czech Republic,** Klecany  
Tel: +420 284 083 111

**DE – Germany,** Kaarst  
Tel: +49 (0)2131 4016 0

**DK – Denmark,** Ballerup  
Tel: +45 43 56 04 00

**ES – Spain,** Madrid  
Tel: +34 902 33 00 01

**FI – Finland,** Vantaa  
Tel: +358 (0)20 753 2500

**FR – France,**  
Contamine-sur-Arve  
Tel: +33 (0)4 50 25 80 25

**GR – Greece,** Athens  
Tel: +30 210 933 6450

**HK – Hong Kong**  
Tel: +852 2428 8008

**HU – Hungary,** Budapest  
Tel: +36 1 220 4155

**IE – Ireland,** Dublin  
Tel: +353 (0)1 466 6370

**IN – India,** Mumbai  
Tel: +91 22 6513 7081-85

**IT – Italy,** Corsico (MI)  
Tel: +39 02 45 19 21

**JP – Japan,** Fujisawa  
Tel: +(81) 4 6635 3050

**KR – South Korea,** Seoul  
Tel: +82 2 559 0400

**KZ – Kazakhstan,** Almaty  
Tel: +7 3272 505 800

**LV – Latvia,** Riga  
Tel: +371 74 52601

**MX – Mexico,** Apodaca  
Tel: +52 81 8156 6000

**MY – Malaysia,** Subang Jaya  
Tel: +60 3 5638 1476

**NL – The Netherlands,**  
Oldenzaal  
Tel: +31 (0)541 585 000

**NO – Norway,** Ski  
Tel: +47 64 91 10 00

**NZ – New Zealand,** Mt Wellington  
Tel: +64 9 574 1744

**PL – Poland,** Warsaw  
Tel: +48 (0)22 573 24 00

**PT – Portugal,** Leca  
da Palmeira  
Tel: +351 22 999 7360

**RO – Romania,** Bucharest  
Tel: +40 21 252 1382

**RU – Russia,** Moscow  
Tel: +7 495 645-2156

**SE – Sweden,** Spånga  
Tel: +46 (0)8 59 79 50 00

**SG – Singapore**  
Tel: +65 6887 6300

**SL – Slovenia,** Novo Mesto  
Tel: +386 7 337 6650

**SK – Slovakia**  
See Czech Republic

**TH – Thailand,** Bangkok  
Tel: +662 717 8140

**TR – Turkey,** Merter/Istanbul  
Tel: +90 212 482 91 06 or 07

**TW – Taiwan,** Taipei  
Tel: +886 2 2298 8987

**UA – Ukraine,** Kyiv  
Tel: +380 44 494 2731

**UK – United Kingdom,**  
Warwick  
Tel: +44 (0)1926 317 878

**US – USA,** Cleveland  
(Industrial)  
Tel: +1 216 896 3000

**US – USA,** Lincolnshire  
(Mobile)  
Tel: +1 847 821 1500

**US – USA,** Miami  
(Pan American Division)  
Tel: +1 305 470 8800

**VE – Venezuela,** Caracas  
Tel: +58 212 238 5422

**ZA – South Africa,**  
Kempton Park  
Tel: +27 (0)11 961 0700

