



aerospace  
climate control  
electromechanical  
filtration  
fluid & gas handling  
hydraulics  
**pneumatics**  
process control  
sealing & shielding



# Pneumatic ISO Cylinders

Series P1D-T - bore  $\varnothing$ 160 -  $\varnothing$ 320 mm  
According to ISO 15552

PDE2667TCUK July 2012



ENGINEERING YOUR SUCCESS.

<b>Contents</b>	<b>page</b>
P1D-T – ISO 15552 Cylinder Range .....	3
Cylinder forces, double acting variants .....	4
Main data : P1D-T .....	4
Operating and environmental data .....	4
General technical data .....	5
Material specification - Bores Ø160, Ø200 and Ø250 mm .....	5
Material specification - Bores Ø320 mm .....	6
Order key code P1D-T .....	7
Standard strokes .....	7
Order code standard strokes P1D-T .....	8
Dimensions .....	9
Cylinder mountings .....	10 - 12
Piston rod mountings .....	13
Sensors .....	14 - 16
Seal kits .....	17
Introduction to ATEX directive .....	18 - 21



**Important**

Before attempting any external or internal work on the cylinder or any connected components, make sure the cylinder is vented and disconnect the air supply in order to ensure isolation of the air supply.



**Note**

All technical data in this catalogue are typical data only.  
Air quality is essential for maximum cylinder service life (see ISO 8573).



**WARNING**

**FAILURE OR IMPROPER SELECTION OR IMPROPER USE OF THE PRODUCTS AND/OR SYSTEMS DESCRIBED HEREIN OR RELATED ITEMS CAN CAUSE DEATH, PERSONAL INJURY AND PROPERTY DAMAGE.**

This document and other information from Parker Hannifin Corporation, its subsidiaries and authorized distributors provide product and/or system options for further investigation by users having technical expertise. It is important that you analyze all aspects of your application and review the information concerning the product or system in the current product catalog. Due to the variety of operating conditions and applications for these products or systems, the user, through its own analysis and testing, is solely responsible for making the final selection of the products and systems and assuring that all performance, safety and warning requirements of the application are met. The products described herein, including without limitation, product features, specifications, designs, availability and pricing, are subject to change by Parker Hannifin Corporation and its subsidiaries at any time without notice.

**SALE CONDITIONS**

The items described in this document are available for sale by Parker Hannifin Corporation, its subsidiaries or its authorized distributors. Any sale contract entered into by Parker will be governed by the provisions stated in Parker's standard terms and conditions of sale (copy available upon request).

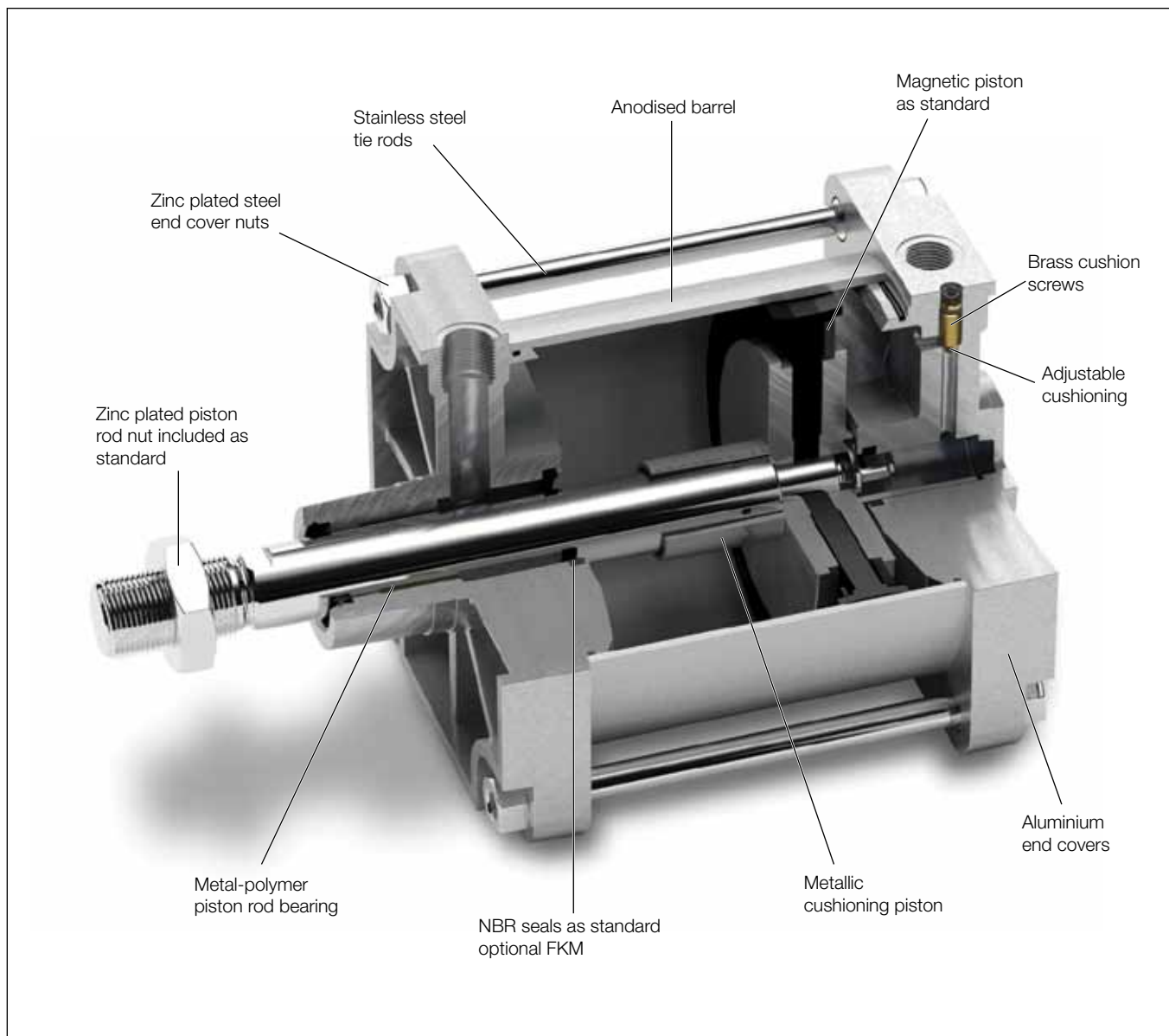

## Standard cylinders P1D-T, ISO 15552 bore Ø160 - Ø320 mm

### Global product range

The P1D-T range of cylinders is intended for use in a wide range of applications.

Careful design and high quality manufacture throughout ensure long service life and optimum economy.

Mounting dimensions fully in accordance with ISO 15552 (ISO 6431 and CETOP RP52P) greatly simplifies installation and world-wide interchangeability.

### Features

- Bore sizes Ø160 - Ø320 mm.
- Stroke lengths 10mm - 2000mm.
- Magnetic piston as standard.
- Adjustable cushioning as standard.
- High temperature version.
- Special versions on request.
- ATEX version.

**P1D-T Pneumatic ISO Cylinders - Ø160 - Ø320 mm****Cylinder forces, double acting variants**

Cyl. bore/ pist. rod mm	Stroke	Piston cm <sup>3</sup>	Max theoretical force in N (bar)									
			1,0	2,0	3,0	4,0	5,0	6,0	7,0	8,0	9,0	10,0
<b>160/40</b>	+	201,0	2010	4019	6029	8038	10048	<b>12058</b>	14067	16077	18086	20096
	-	188,4	1884	3768	5652	7536	9420	<b>11304</b>	13188	15072	16956	18840
<b>200/50</b>	+	314,2	3142	6283	9425	12566	15708	<b>18850</b>	21991	25133	28274	31416
	-	294,5	2945	5891	8836	11781	14727	<b>17672</b>	20617	23562	26508	29453
<b>250/50</b>	+	490,9	4909	9818	14726	19635	24544	<b>29453</b>	34362	39270	44179	49088
	-	471,3	4713	9425	14138	18850	23563	<b>28275</b>	32988	37700	42413	47125
<b>320/63</b>	+	804,25	8043	16085	24128	32170	40213	<b>48255</b>	56298	64340	72383	80425
	-	773,1	7731	15462	23192	30923	38654	<b>46385</b>	54116	61846	69577	77308

+ = Outward stroke  
- = Return stroke

**Note!**

Select a theoretical force 50-100% larger than the force required

**Main data: P1D-T**

Cylinder designation	Cylinder		Piston rod		Piston rod thread	Cushioning length mm	Consumption <sup>2)</sup> litre	Connection thread
	bore mm	area cm <sup>3</sup>	dia. mm	area cm <sup>3</sup>				
P1D-T160••-XXXX	160	201,0	40	12,6	M36x2	52	2,815	G3/4
P1D-T200••-XXXX	200	314,2	50	19,6	M36x2	52	4,398	G3/4
P1D-T250••-XXXX	250	490,9	50	19,6	M42x2	52	6,872	G1
P1D-T320••-XXXX	320	804,3	63	31,2	M48x2	50	11,259	G1

**Total mass including parts**

Cylinder designation	Total mass (kg)	
	at 0 mm stroke	Supplement per 10 mm stroke
P1D-T160••-XXXX	10,45	0,205
P1D-T200••-XXXX	17,80	0,220
P1D-T250••-XXXX	31,00	0,40
P1D-T320••-XXXX	60,00	0,60

**Operating and environmental data**

Operating medium	For best possible service life and trouble-free operation dry, filtered compressed air to ISO 8573-1:2010 quality class 3.4.3 should be used. This specifies a dew point of +3°C for indoor operation (a lower dew point should be selected for outdoor operation) and is in line with the air quality from most standard compressors with a standard filter.
Operating pressure	1,0 bar to 10 bar
Ambient temperature	
Standard version	-20°C to +80°C
High temperature version	-10°C to +140°C
Pre-lubricated	Further lubrication is normally not necessary. If additional lubrication is introduced it must be continued.
Corrosion resistance	High resistance to corrosion and chemicals. Materials and surface treatment have been selected for industrial applications where solvents and detergents are frequently used.

**General technical data**

Product type	Standard cylinder according to ISO 15552	
Bore size	160 - 320 mm	
Stroke length	10-2000 mm	
Versions	P1D-T...XX	Double acting
Cushioning	Adjustable air cushioning	
Position sensing	Proximity sensor	
Installation	P1D cylinder and piston rod mountings	
Mounting position	Any	

**Material specification - Bores Ø160, Ø200 and Ø250 mm.**

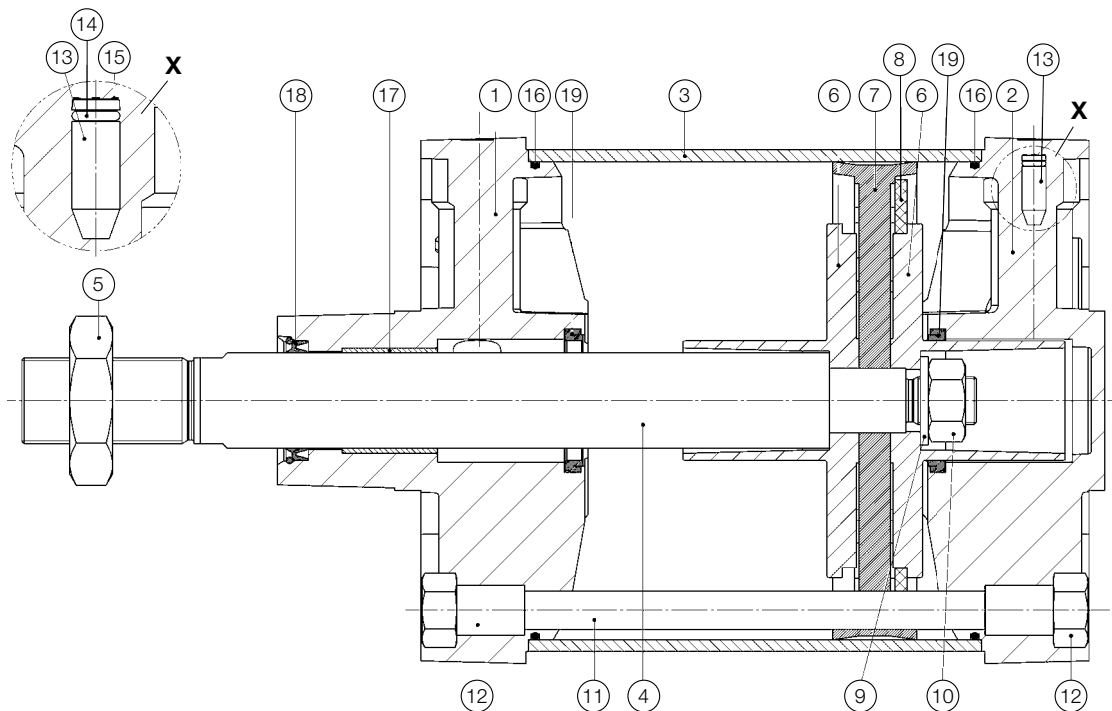

Pos	Part	Specification
1	Front cover	Aluminium
2	Rear cover	Aluminium
3	Cylinder barrel	Anodised aluminium
4	Piston rod	Standard: High alloyed steel 1.4104 (X12CrMoS17) Option: Stainless steel 1.4305 (X10CrNiS18.9)
5	Piston rod nut	Zinc plated steel
6	Cushioning piston	Aluminium
7	Piston seal	Standard: NBR Option: FKM
8	Magnet	Magnet foil
9	Washer	Zinc plated steel
10	Piston nut	Zinc plated steel
11	Tie rod	High alloyed steel 1.4104 (X12CrMoS17)
12	Tie rod nut	Zinc plated steel
13	Cushioning screw	Brass
14	Cushioning O ring	Standard: NBR Option: FKM
15	Retaining clip	Spring steel
16	O ring	Standard: NBR Option: FKM
17	Rod bearing	Metal-polymer material
18	Rod seal	Standard: NBR Option: FKM
19	Cushion seal	Standard: NBR Option: FKM

Materials RoHS compliant

## Material specification - Bores Ø320 mm.

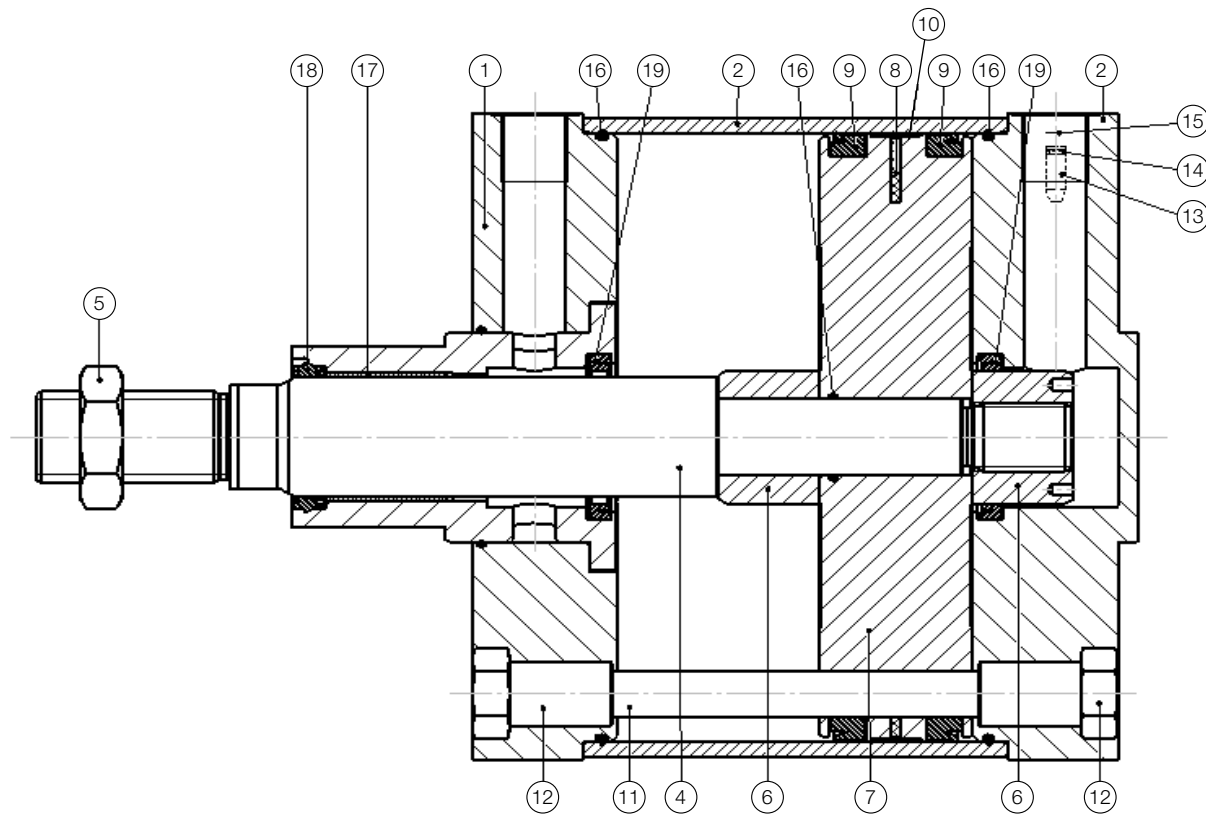

Pos	Part	Specification
1	Front cover	Aluminium
2	Rear cover	Aluminium
3	Cylinder barrel	Anodised aluminium
4	Piston rod	Standard: Chrome steel 1.5217 (20MnV6) Option: Stainless steel 1.4305 (X10CrNiS18.9)
5	Piston rod nut	Zinc plated steel
6	Cushioning piston	Burnished steel (gunmetal-finished)
7	Piston	Aluminium
8	Magnet	Plastomag (Magnet foil)
9	Piston seals	Standard: NBR Option: FKM
10	Piston bearing	PTFE + Carbon
11	Tie rod	Stainless steel 1.4305 (X10CrNiS18.9)
12	Tie rod nut	Zinc plated steel
13	Cushioning screw	Brass
14	Cushioning O ring	Standard: NBR Option: FKM
15	Retaining clip	Spring steel
16	O ring	Standard: NBR Option: FKM
17	Rod bearing	IGLIDUR G plastic
18	Rod seal	Standard: NBR Option: FKM
19	Cushion seal	Standard: NBR Option: FKM

Order Key Code

**15-digit order code**

1 2 3 4 5 6 7 8 9 10 11 12 13 14 15

**P 1 D - T 1 6 0 M S - 0 5 0 0**

**20-digit order code**

16 17 18 19 20

**N D N N N**

**4**

**Cylinder type**

-	Standard with cushioning and magnetic piston
F	Standard with cushioning without magnet piston

**9**

**Function**

M	Standard scraper
Q	Metallic scraper
V	FPM scraper
F	Thru rod, standard scraper
R	Thru rod, metallic scraper
B	Thru rod, FPM scraper

**12-13-14-15**

**Stroke (mm) e.g. 0100 = 100 mm**

Optional stroke lengths up to 2000 mm. Standard strokes see table below.

**6-7-8**

**Cylinder bore mm**

160
200
250
320

**16-17-18**

**ATEX Version e.g. P1D-T160MS-0500-EX**

-EX	According to ATEX
-----	-------------------

**10**

Piston rod Material			Seals
Stainless steel (1)	High alloy steel (2)	Chromium plated steel (3)	
<b>S</b>	<b>T</b>	<b>C</b>	Standard -20°C to +80°C.
<b>F</b>	<b>V</b>	<b>G</b>	High temperature version -10°C to +140°C. No magnetic function

**17-18-19-20**

**Cylinder trunnion**

Shaft 90°	Shaft inline	
<b>D</b>	<b>6</b>	Cylinder trunnion in centre position
<b>G</b>	<b>7</b>	Cylinder trunnion (XV measure in pos 18-20)

Further options available, please consult Sales Office for advice.

**II 2GD c T4 120 °C**

(1) For bore Ø320mm please consult sales office  
 (2) Not available on bore Ø320mm  
 (3) Not available on bores Ø160 - 250mm.

**Standard strokes**

Standard strokes for all P1D-T cylinders comply with ISO 4393. Special strokes up to 2000 mm.

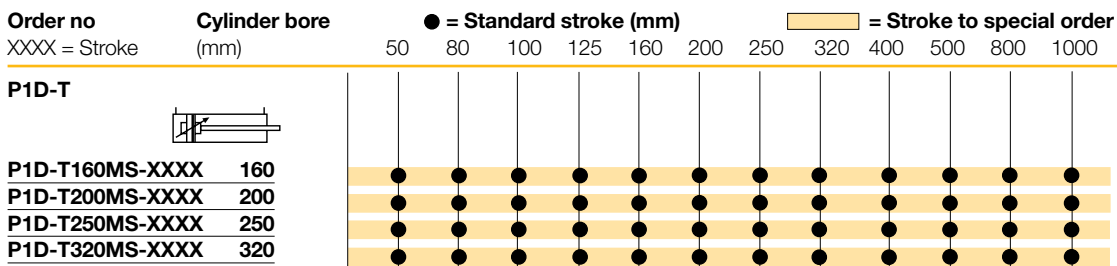

**P1D-T Pneumatic ISO Cylinders - Ø160 - Ø320 mm**

**Double acting with stainless steel piston rod**

- Bore sizes Ø160 - Ø320mm
- Stroke lengths 10mm - 2000mm
- Magnetic piston as standard
- Adjustable cushioning as standard
- High temperature versions
- ATEX version
- Special versions on request

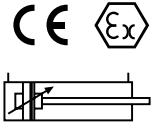

**P1D-T - Double acting**

**Ø160mm**

Stroke mm	Order code
50	P1D-T160MS-0050
80	P1D-T160MS-0080
100	P1D-T160MS-0100
125	P1D-T160MS-0125
160	P1D-T160MS-0160
200	P1D-T160MS-0200
250	P1D-T160MS-0250
320	P1D-T160MS-0320
400	P1D-T160MS-0400
500	P1D-T160MS-0500
800	P1D-T160MS-0800
1000	P1D-T160MS-1000

**Ø200mm**

Stroke mm	Order code
50	P1D-T200MS-0050
80	P1D-T200MS-0080
100	P1D-T200MS-0100
125	P1D-T200MS-0125
160	P1D-T200MS-0160
200	P1D-T200MS-0200
250	P1D-T200MS-0250
320	P1D-T200MS-0320
400	P1D-T200MS-0400
500	P1D-T200MS-0500
800	P1D-T200MS-0800
1000	P1D-T200MS-1000

**Ø250mm**

Stroke mm	Order code
50	P1D-T250MS-0050
80	P1D-T250MS-0080
100	P1D-T250MS-0100
125	P1D-T250MS-0125
160	P1D-T250MS-0160
200	P1D-T250MS-0200
250	P1D-T250MS-0250
320	P1D-T250MS-0320
400	P1D-T250MS-0400
500	P1D-T250MS-0500
800	P1D-T250MS-0800
1000	P1D-T250MS-1000

**Ø320mm**

Stroke mm	Order code
50	P1D-T320MS-0050
80	P1D-T320MS-0080
100	P1D-T320MS-0100
125	P1D-T320MS-0125
160	P1D-T320MS-0160
200	P1D-T320MS-0200
250	P1D-T320MS-0250
320	P1D-T320MS-0320
400	P1D-T320MS-0400
500	P1D-T320MS-0500
800	P1D-T320MS-0800
1000	P1D-T320MS-1000

The cylinders are supplied complete with a zinc plated steel piston rod nut.



**Dimensions - Basic Cylinder**

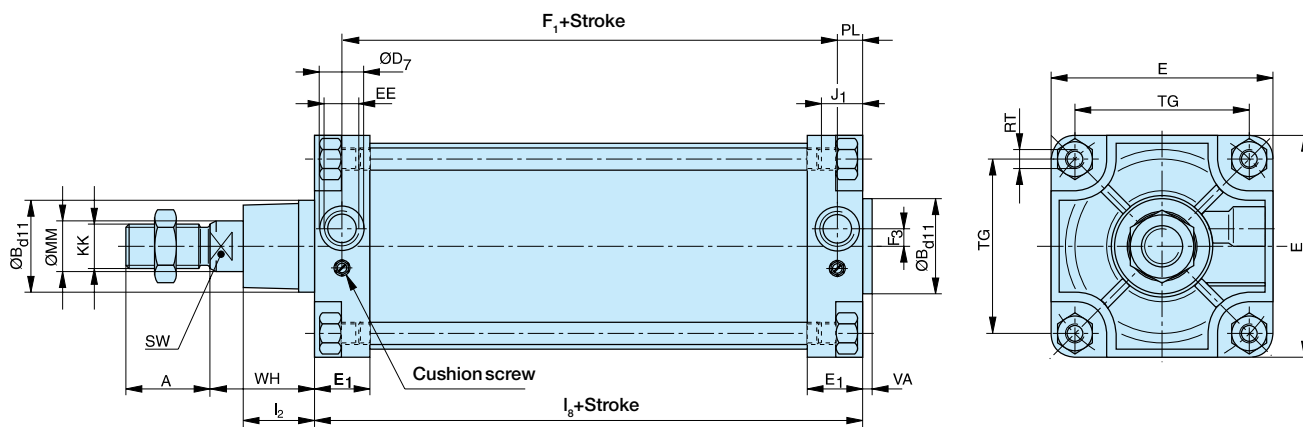

**Dimension Table (mm) – for Basic Cylinder**

Cyl. Ø	A	ØB <sub>d11</sub>	ØD <sub>7</sub>	E	E <sub>1</sub>	F <sub>1</sub> + Stroke	F <sub>3</sub>	J <sub>1</sub> max.	I <sub>2</sub>	I <sub>8</sub> + Stroke	EE	KK	MM	PL	RT	SW	TG	VA	WH
160	72	65	33	180	45	130	11	23	50	180	G3/4	M36x2	40	25	M16	36	140	6	80
200	72	75	33	220	45	130	15	23	60	180	G3/4	M36x2	40	25	M16	36	175	6	95
250	84	90	40	280	64	136	21	27	70	200	G 1	M42x2	50	32	M20	46	220	10	105
320	96	110	44	340	55	158	-	28	89,5	220	G1	M48x2	63	31	M24	55	270	9,5	120

**Weight (mass) kg**

Cylinder version	Cylinder Diameter							
	Ø160		Ø200		Ø250		Ø320	
	1*	2*	1*	2*	1*	2*	1*	2*
Standard Type P1D-T	12.500	2.050	20.000	2.200	35.000	4.000	66.000	6.000

\* 1 = Weight for cylinder with 100 mm stroke  
 2 = Weight for further 100 mm stroke length

**Tolerances**

Cylinder bore mm	L <sub>8</sub> mm	TG mm	Stroke tolerance up to stroke 500 mm	Stroke tolerance for stroke over 500 mm
160	±1,1	±1,1	+0,3/+2,0	+0,3/+3,0
200	±1,6	±1,1	+0,3/+2,0	+0,3/+3,0
250	±1,6	±1,5	+0,3/+2,0	+0,3/+3,0
320	±2,2	±1,5	+0,3/+2,0	+0,3/+3,0

Cylinder mountings

Flange MF1/MF2



Intended for fixed mounting of cylinder. Flange can be fitted to front or rear end cover of cylinder.

Materials  
Flange: Passivated steel  
Mounting screws acc. to DIN 6912:  
Zinc-plated steel 8.8

Supplied complete with mounting screws for attachment to cylinder.

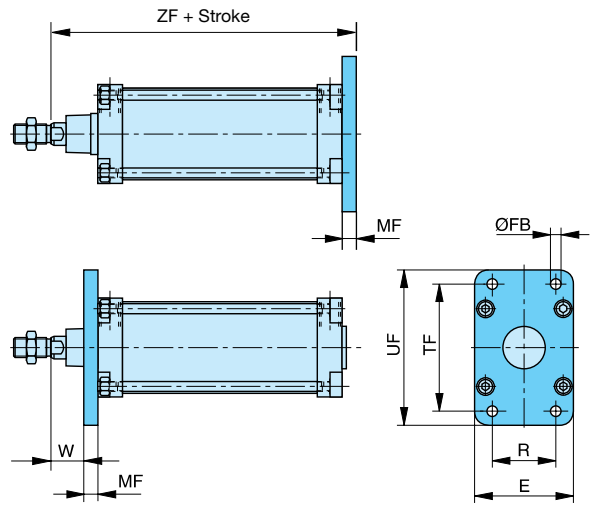

According to ISO MF1/MF2, VDMA 24 562, AFNOR

Cyl. Ø mm	E mm	R mm	W mm	ØFB mm	MF mm	TF mm	UF mm	ZF mm	Weight kg	Order code
160	180	115	60	18	20	230	275	280	7.2	PD23410
200	220	135	70	22	25	270	315	300	12.2	PD24924
250	280	165	80	26	25	330	380	330	19.2	PD25761
320	353	200	90	33	30	400	475	370	38.0	KL9140

Foot bracket MS1



Intended for fixed mounting of cylinder. Foot bracket can be fitted to front and rear end covers of cylinder.

Materials  
Foot bracket: Passivated steel  
Mounting screws acc. to DIN 912: Zinc-plated steel 8.8

Supplied in pairs with mounting screws for attachment to cylinder.

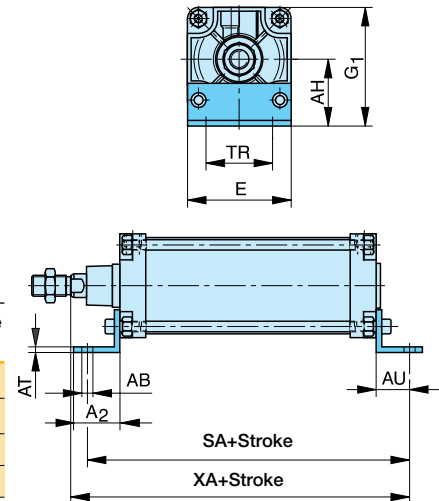

According to ISO MS1, VDMA 24 562, AFNOR

Cyl. Ø mm	A <sub>2</sub> mm	E mm	G <sub>1</sub> mm	AB mm	AH mm	AT mm	AU mm	SA + stroke	TR + stroke	XA + stroke	Weight kg	Order code
160	80	180	205	18	115	8	60	300	115	320	3.8	PD22027
200	100	220	245	22	135	9	70	320	135	345	5.0	PD24792
250	110	280	305	26	165	10	75	350	165	380	9.7	PD25758
320	130	353	370	35	200	23	85	390	200	425	17.0	KL9139

Pivot bracket with rigid bearing



Intended for flexible mounting of cylinder. The pivot bracket can be combined with clevis bracket MP2. Bracket includes pin and circlips DIN 471

Materials  
Pivot bracket: Ø 160-200: cast aluminium  
Ø 250-320: cast steel

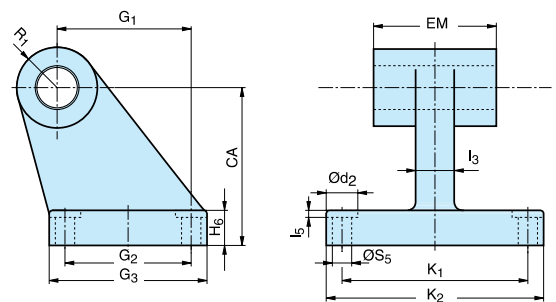

According to CETOP RP 107 P, VDMA 24 562, AFNOR

Cyl. Ø mm	Ød <sub>2</sub> mm	l <sub>3</sub> mm	l <sub>5</sub> mm	G <sub>1</sub> mm	G <sub>2</sub> mm	G <sub>3</sub> mm	H <sub>6</sub> mm	K <sub>1</sub> mm	K <sub>2</sub> mm	R <sub>1</sub> mm	ØS <sub>5</sub> mm	CA mm	EM mm	Weight kg	Order code
160	20	36	4.0	97	88	126	25	118	156	31.5	14.0	115	90	6.5	P1C-4SMDB
200	26	40	4.0	105	90	130	30	122	162	31.5	18.0	135	90	8.0	P1C-4TMDB
250	33	45	4.5	128	110	160	35	150	200	40	22.0	165	110	13.5	P1C-4UMDC
320	40	55	4.5	150	122	186	40	170	234	45	26.0	200	120	21.9	P1C-4VMDC

**Cylinder mountings**

**Swivel eye bracket**

Intended for use together with clevis bracket GA



Material  
Bracket: Cast aluminium  
Swivel bearing acc. to DIN 648K: Hardened steel

Supplied complete with mounting screws for attachment to cylinder.

According to VDMA 24 562, AFNOR

Cyl. Ø mm	H <sub>4</sub> mm	H <sub>7</sub> mm	H <sub>8</sub> mm	Ø CX <sup>H7</sup> mm	DL mm	EX mm	MS mm	XN + stroke mm	Weight kg	Order code
160	35	28.5	20	30	55	37	48	315	2.6	<b>PD23850</b>
200	36	33	24	35	60	43	47	335	11.3	<b>PD25766</b>
250	42	39	28	40	70	49	53	375	19.0	<b>PD25760</b>
320	50	26	30	50	80	60	63	420	30.3	<b>KL9136</b>

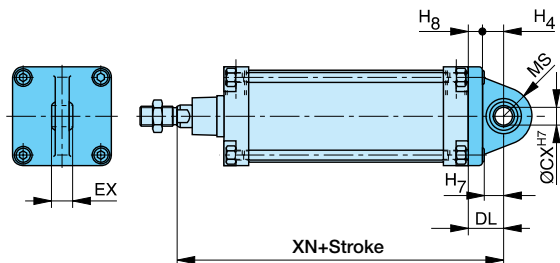

**Clevis bracket MP2**

Intended for flexible mounting of cylinder. Clevis bracket MP2 can be combined with clevis bracket MP4.



Materials  
Clevis bracket: Cast aluminium  
Pin: Hardened steel  
Circlips according to DIN 471: Spring steel  
Mounting screws acc. to DIN 912: Zinc-plated steel 8.8

Supplied complete with mounting screws for attachment to cylinder

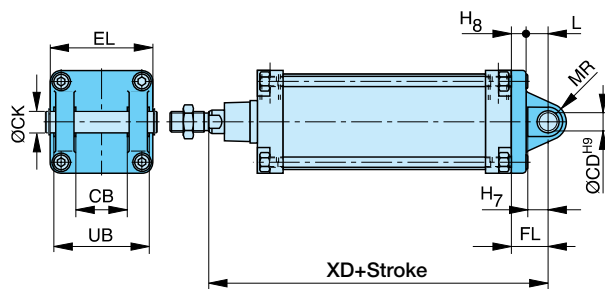

According to ISO MP2, VDMA 24 562, AFNOR

Cyl. Ø mm	H <sub>7</sub> mm	H <sub>8</sub> mm	L mm	EL mm	CD <sup>H9</sup> mm	CB mm	FL mm	MR mm	UB mm	XD + stroke mm	CK <sup>H9</sup> mm	Weight kg	Order code
160	28.5	20	35	172	30	90	55	30	170	315	30	2.6	<b>P1C-4SMTB</b>
200	28.5	25	35	172	30	90	60	31	170	335	30	4.1	<b>P1C-4TMTB</b>
250	25.0	25	45	202	40	110	70	41	200	375	40	7.1	<b>P1C-4UMTB</b>
320	26.0	30	50	222	45	120	80	46	220	420	45	31.0	<b>P1C-4VMTB</b>

**Clevis bracket MP4**

Intended for flexible mounting of cylinder. Clevis bracket MP4 can be combined with clevis bracket MP2.



Materials  
Clevis bracket: Cast aluminium  
Mounting screws acc. to DIN 912: Zinc-plated steel 8.8

Supplied complete with mounting screws for attachment to cylinder.

According to ISO MP4, VDMA 24 562, AFNOR

Cyl. Ø mm	H <sub>7</sub> mm	H <sub>8</sub> mm	L mm	CD <sup>H9</sup> mm	EW mm	FL mm	MR mm	XD + stroke mm	Weight kg	Order code
160	28.5	20	35	30	90	55	30	315	2.7	<b>PD22628</b>
200	28.5	25	35	30	90	60	31	335	4.2	<b>PD24999</b>
250	25.0	25	45	40	110	70	41	375	15.7	<b>PD25759</b>
320	26.0	30	50	45	120	80	46	420	33.0	<b>KL9135</b>

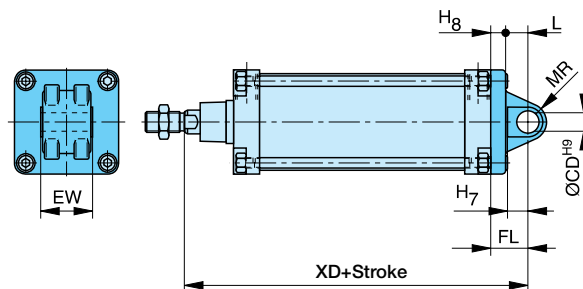

**Cylinder mountings**

**Pivot bracket for MT4**

Intended for use together with central trunnion MT4.



Material  
 Pivot bracket: Ø160-250 mm – Anodised aluminium  
 Ø 320 mm – steel  
 Bearing acc. to DIN 1850 C

Supplied in pairs.

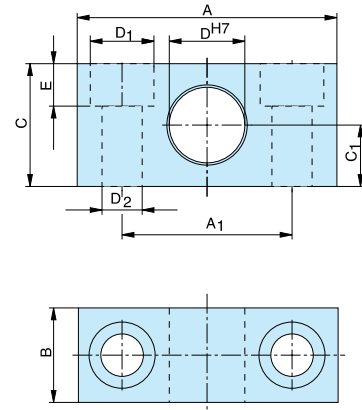

According to ISO, VDMA 24 562, AFNOR

Cyl. Ø mm	A mm	A <sub>1</sub> mm	B mm	C mm	C <sub>1</sub> mm	ØD <sup>H7</sup> mm	ØD <sub>1</sub> mm	ØD <sub>2</sub> mm	E mm	Weight kg	Order code
160	92	60	35	60	30	32	26	18	17.0	0.35	<b>PD24425</b>
200	92	60	35	60	30	32	26	18	17.0	0.35	<b>PD24425</b>
250	140	90	40	70	35	40	33	22	21.5	0.50	<b>PD25763</b>
320	150	100	60	80	40	50	40	26	25.5	6.70	<b>KL9130</b>

**Centre trunnion MT4 for P1D-T**



Intended for articulated mounting of cylinder. The trunnion is factory-fitted in the centre of the cylinder or at an optional location specified by the XV-measure - Combined with pivot bracket for MT4.

Material:  
 Trunnion: Zinc plated steel

**Trunnion centred**

The central trunnion for the P1D-T is ordered with letter D in position 17 (no dimension specified in positions 18-20). e.g. P1D-T160MS-0500NDNNN

**Trunnion with optional location**

The central trunnion for the P1D-T is ordered with letter G in position 17 and desired XV-measure (3-digit measure in mm) in positions 18-20. e.g. P1D-T160MS-0500NG300

Material: nodular graphite cast iron, passivated steel

According to ISO MT4, VDMA 24 562, AFNOR

Cyl. Ø mm	TD <sub>e9</sub> mm	TK mm	TL mm	TM mm	UW mm	XV mm	XV <sub>min</sub> mm	XV <sub>+1/2 stroke</sub> mm	XV <sub>max</sub> mm	Weight kg	Order code
160	32	45	32	200	210	150	170	190	6.1	<b>See order code key on page 7</b>	
200	32	50	32	250	245	165	185	205	8.1		
250	40	55	40	320	320	195	205	210	14.8		
320	50	70	50	400	400	210	230	250	16.0		

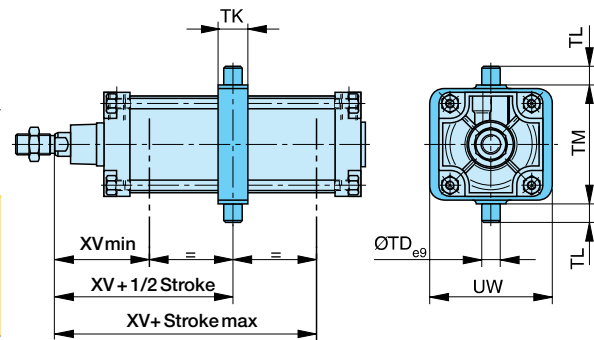

\* Please consult Sales Office.

**Piston rod mountings**

**Swivel rod eye**

Intended for articulated mounting of the cylinder.  
Maintenance-free PTFE.

Material:  
Swivel rod eye, nut: galvanized steel.  
Swivel bearing according to DIN 648K: Hardened steel.

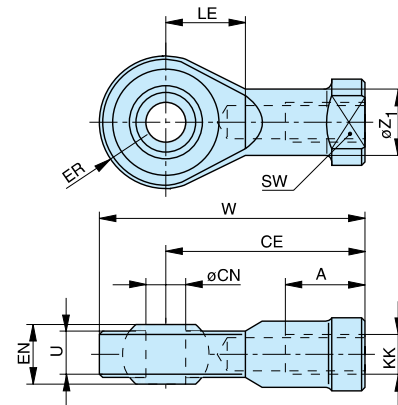

ISO 8139

Cyl. Ø mm	CN <sup>H7</sup> mm	LE mm	U mm	EN mm	ER mm	W mm	A mm	CE mm	KK mm	ØZ <sub>1</sub> mm	SW mm	Weight kg	Order code
					max.	max.	min.						
160	35	41	28	43	40	165	56	125	M36x2	46	50	1.6	<b>KY6863</b>
200	35	41	28	43	40	165	56	125	M36x2	46	50	1.6	<b>KY6863</b>
250	40	46	33	49	45	187	60	142	M42x2	53	55	3.5	<b>KY6864</b>
320	50	59	45	60	58	218	65	160	M48x2	65	65	5.2	<b>KL9132</b>

**Clevis**

Intended for articulated mounting of the cylinder.

Material:  
Clevis and clip galvanized steel.  
Pin: Hardened steel

Supplied complete with pin.

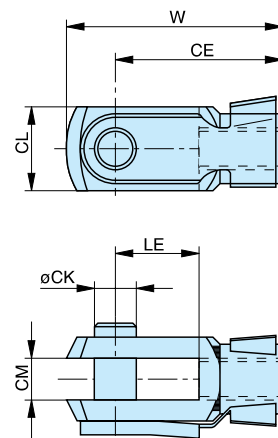

Cyl. Ø mm	ØCK mm	LE mm	CM mm	CL mm	W mm	CE mm	KK mm	Weight kg	Order code
						max.			
160	35	72	36	70	188	144	M36x2	2.9	<b>KY6867</b>
200	35	72	36	70	188	144	M36x2	2.9	<b>KY6867</b>
250	40	84	40	85	245	168	M42x2	6.0	<b>KY6868</b>
320	50	96	50	96	277	192	M48x2	7.9	<b>KL9131</b>

**Flexo coupling**

Flexo coupling for articulated mounting of piston rod.  
Flexo fitting is intended to take up axial angle errors within a range of ±4°.

Material  
Flexo coupling, nut: Zinc-plated steel  
Socket: Hardened steel

Supplied complete with galvanized adjustment nut.

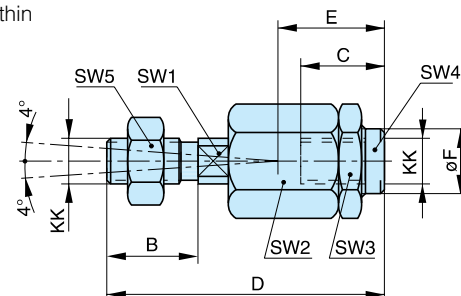

Cyl. Ø mm	KK mm	B mm	C mm	D mm	E mm	ØF mm	SW1 mm	SW2 mm	SW3 mm	SW4 mm	SW5 mm	Weight kg	Order code
160	M36x2	72	50	241	110	56	36	75	75	50	55	5.1	<b>KY1139</b>
200	M36x2	72	50	241	110	56	36	75	75	50	55	5.1	<b>KY1139</b>
250	M42x2	82	88	271	120	-	36	80	80	60	65	7.9	<b>KY1140</b>
320	M48x2	82	88	271	120	-	42	80	80	60	75	7.9	<b>KL9133</b>

## Drop-in sensors

The P1D sensors can easily be installed from the side in the sensor groove, at any position along the piston stroke. The sensors are completely recessed and thus mechanically protected. Choose between electronic or reed sensors and several cable lengths and 8 mm and M12 connectors. The same standard sensors are used for all P1D versions.



## Electronic sensors

The electronic sensors are "Solid State", i.e. they have no moving parts at all. They are provided with short-circuit protection and transient protection as standard. The built-in electronics make the sensors suitable for applications with high on and off switching frequency, and where very long service life is required.

### Technical data

Design	GMR (Giant Magnetic Resistance) magneto-resistive function
Installation	From side, down into the sensor groove, so-called drop-in
Outputs	PNP, normally open (also available in NPN design, normally closed, on request)
Voltage range	10-30 VDC 10-18 V DC, ATEX sensor
Ripple	max 10%
Voltage drop	max 2,5 V
Load current	max 100 mA
Internal consumption	max 10 mA
Actuating distance	min 9 mm
Hysteresis	max 1,5 mm
Repeatability accuracy	max 0,2 mm
On/off switching frequency	max 5 kHz
On switching time	max 2 ms
Off switching time	max 2 ms
Encapsulation	IP 67 (EN 60529)
Temperature range	-25 °C to +75 °C -20 °C to +45 °C, ATEX sensor
Indication	LED, yellow
Material housing	PA 12
Material screw	Stainless steel
Cable	PVC or PUR 3x0.25 mm <sup>2</sup> see order code respectively

## Reed sensors

The sensors are based on proven reed switches, which offer reliable function in many applications. Simple installation, a protected position on the cylinder and clear LED indication are important advantages of this range of sensors.

### Technical data

Design	Reed element
Mounting	From side, down into the sensor groove, so-called drop-in
Output	Normally open, or normally closed
Voltage range	10-30 V AC/DC or 10-120 V AC/DC 24-230 V AC/DC
Load current	max 500 mA for 10-30 V or max 100 mA for 10-120 V max 30 mA for 24-230 V
Breaking power (resistive)	max 6 W/VA
Actuating distance	min 9 mm
Hysteresis	max 1,5 mm
Repeatability accuracy	0,2 mm
On/off switching frequency	max 400 Hz
On switching time	max 1,5 ms
Off switching time	max 0,5 ms
Encapsulation	IP 67 (EN 60529)
Temperature range	-25 °C to +75 °C
Indication	LED, yellow
Material housing	PA12
Material screw	Stainless steel
Cable	PVC or PUR 3x0.14 mm <sup>2</sup> see order code respectively

Electronic sensors

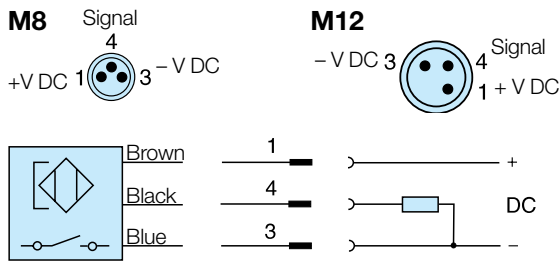

Reed sensors

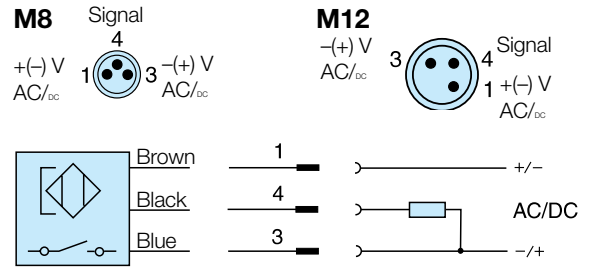

P8S-GCFPX

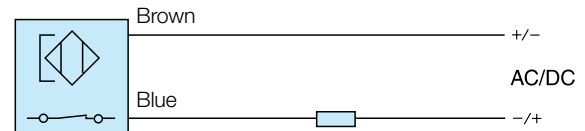

P8S-GRFLX / P8S-GRFLX2

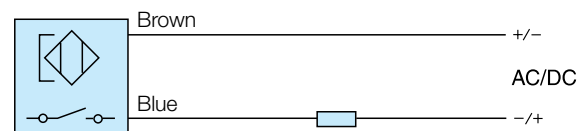

Dimensions

Sensors

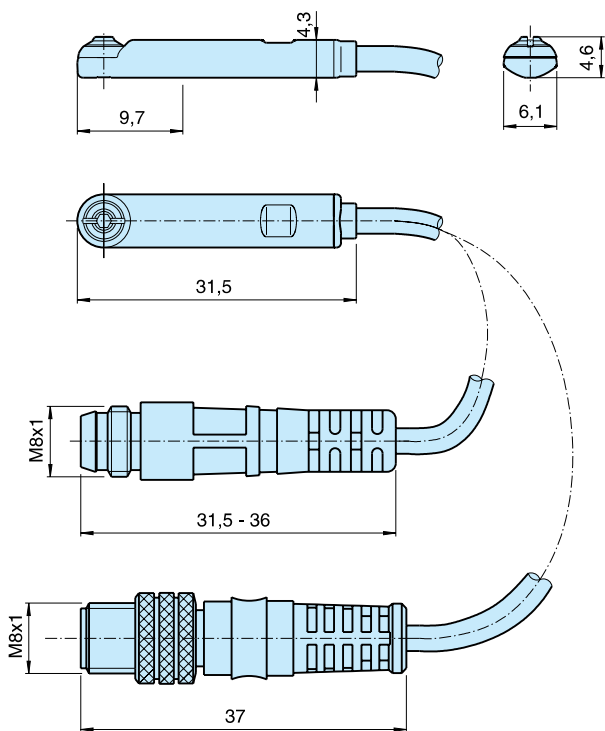

Sensor mounting - P1D-T 160 - 320mm

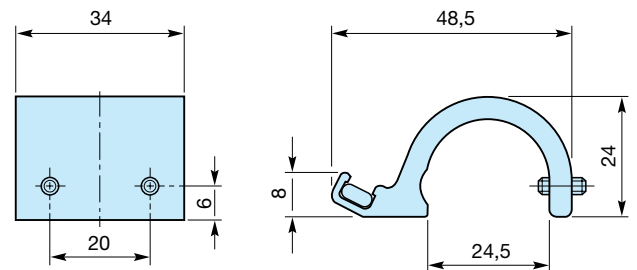

Order code

**PD48956**

## Ordering data

Output/function	Cable/connector	Weight kg	Order code
<b>Electronic sensors , 10-30 V DC</b>			
PNP type, normally open	0,27 m PUR-cable and 8 mm snap-in male connector	0,007	<b>P8S-GPSHX</b> <b>P8S-GPMHX</b> <b>P8S-GPFLX</b> <b>P8S-GPFTX</b>
PNP type, normally open	0,27 m PUR-cable and M12 screw male connector	0,015	
PNP type, normally open	3 m PVC-cable without connector	0,030	
PNP type, normally open	10 m PVC-cable without connector	0,110	
<b>Reed sensors , 10-30 V AC/DC</b>			
Normally open	0,27 m PUR-cable and 8 mm snap-in male connector	0,007	<b>P8S-GSSHX</b> <b>P8S-GSMHX</b> <b>P8S-GSFLX</b> <b>P8S-GSFTX</b> <b>P8S-GCFPX</b>
Normally open	0,27 m PUR-cable and M12 screw male connector	0,015	
Normally open	3 m PVC-cable without connector	0,030	
Normally open	10 m PVC-cable without connector	0,110	
Normally closed	5m PVC-cable without connector <sup>(1)</sup>	0,050	
<b>Reed sensors, 10-120 V AC/DC</b>			
Normally open	3 m PVC-cable without connector	0,030	<b>P8S-GRFLX</b>
<b>Reed sensorer, 24-230 V AC/DC</b>			
Normally open	3 m PVC-cable without connector	0,030	<b>P8S-GRFLX2</b>

1) Without LED

## Sensor mounting

Description	Weight kg	Order code
Sensor mounting for P1D-T 160 - 320mm	0,040	<b>PD48956</b>

## Connecting cables with one connector

The cables have an integral snap-in female connector.



Type of cable	Cable/connector	Weight kg	Order code
<b>Cables for sensors, complete with one female connector</b>			
Cable, Flex PVC	3 m, 8 mm Snap-in connector	0,07	<b>9126344341</b>
Cable, Flex PVC	10 m, 8 mm Snap-in connector	0,21	<b>9126344342</b>
Cable, Polyurethane	3 m, 8 mm Snap-in connector	0,01	<b>9126344345</b>
Cable, Polyurethane	10 m, 8 mm Snap-in connector	0,20	<b>9126344346</b>
Cable, Polyurethane	5 m, M12 screw connector	0,07	<b>9126344348</b>
Cable, Polyurethane	10 m, M12 screw connector	0,20	<b>9126344349</b>

## Male connectors for connecting cables

Cable connectors for producing your own connecting cables. The connectors can be quickly attached to the cable without special tools. Only the outer sheath of the cable is removed. The connectors are available for M8 and M12 screw connectors and meet protection class IP 65.



Connector	Weight kg	Order code
M8 screw connector	0,017	<b>P8CS0803J</b>
M12 screw connector	0,022	<b>P8CS1204J</b>



**P1D-T Seal Kits**

Complete seal kits consisting of:  
 Piston complete  
 Cushioning seals  
 Piston rod bearing  
 Scraper ring  
 Piston rod seal  
 O-rings

Material specification, see page 5



**P1D-T Seal Kits**

Cyl.bore mm	Standard	High Temp.
160	PD23013	PD26995
200	PD25006	PD27427
250	PD25872	PD27976
320	PY00031	KL7325

**Grease for P1D-T**

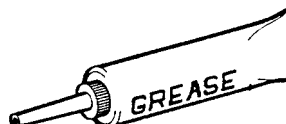



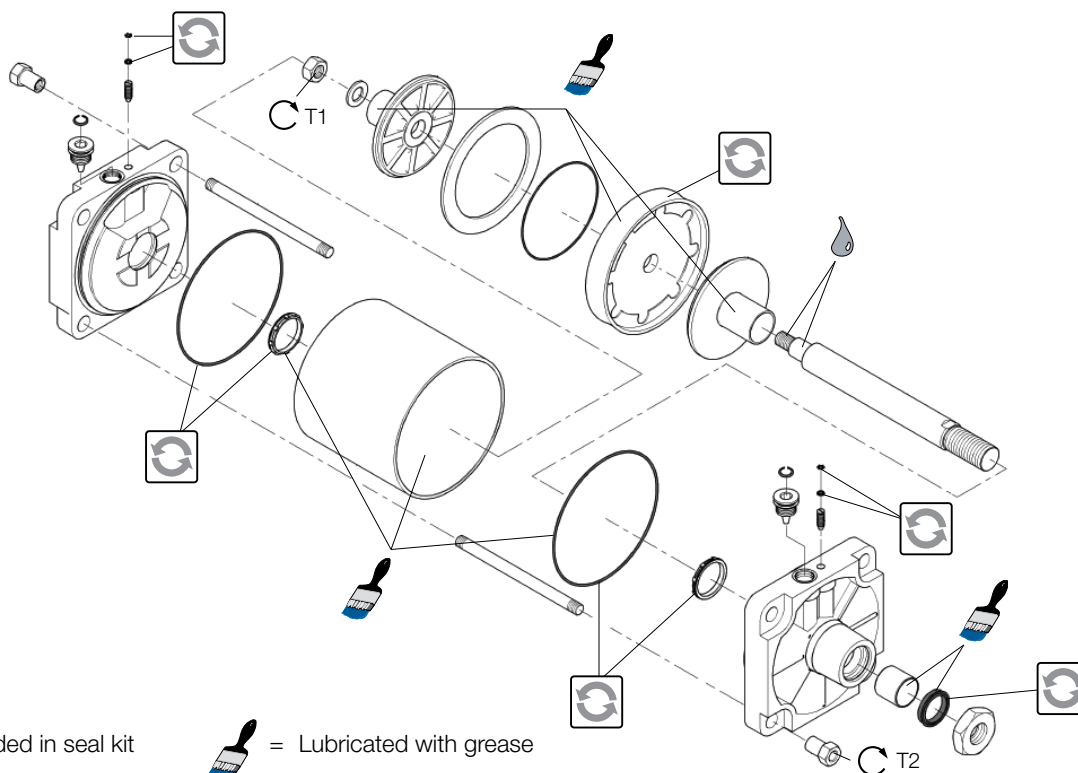

	Standard	4g tube	<b>KL8220</b>
	High temperature	4g tube	<b>KL8220</b>

**P1D-T Optional cylinder versions**

Cyl.bore mm	Through rod Standard temperature
160	P1D-6SRNF
200	P1D-6TRNF
250	P1D-6URNF
320	P1D-6VRNF

**Seal kit for bores Ø160 - Ø250 mm**



-  = Included in seal kit
-  = Lubricated with grease
-  = Socket head
-  = Locking fluid
-  = Tightening torque
-  = Nut A/F

Loctite LT638 locking fluid must be used

For bore Ø320 please consult sales company

Cyl.-dia mm	Plastic piston T1 Nm	NV mm	T2 Nm	NV mm
160	100	30	85	27
200	100	30	95	27
250	120	36	140	41



# Specifying air quality (purity) in accordance with ISO8573-1:2010, the international standard for Compressed Air Quality

ISO8573-1 is the primary document used from the ISO8573 series as it is this document which specifies the amount of contamination allowed in each cubic metre of compressed air.

ISO8573-1 lists the main contaminants as Solid Particulate, Water and Oil. The purity levels for each contaminant are shown separately in tabular form, however for ease of use, this document combines all three contaminants into one easy to use table.

ISO8573-1:2010 CLASS	Solid Particulate			Mass Concentration mg/m <sup>3</sup>	Water		Oil
	Maximum number of particles per m <sup>3</sup>				Vapour Pressure Dewpoint	Liquid g/m <sup>3</sup>	Total Oil (aerosol liquid and vapour) mg/m <sup>3</sup>
	0,1 - 0,5 micron	0,5 - 1 micron	1 - 5 micron				
0	As specified by the equipment user or supplier and more stringent than Class 1						
1	≤ 20 000	≤ 400	≤ 10	-	≤ -70 °C	-	0,01
2	≤ 400 000	≤ 6 000	≤ 100	-	≤ -40 °C	-	0,1
3	-	≤ 90 000	≤ 1 000	-	≤ -20 °C	-	1
4	-	-	≤ 10 000	-	≤ +3 °C	-	5
5	-	-	≤ 100 000	-	≤ +7 °C	-	-
6	-	-	-	≤ 5	≤ +10 °C	-	-
7	-	-	-	5 - 10	-	≤ 0,5	-
8	-	-	-	-	-	0,5 - 5	-
9	-	-	-	-	-	5 - 10	-
X	-	-	-	> 10	-	> 10	> 10

## Specifying air purity in accordance with ISO8573-1:2010

When specifying the purity of air required, the standard must always be referenced, followed by the purity class selected for each contaminant (a different purity class can be selected for each contamination if required).

An example of how to write an air quality specification is shown below:

### ISO 8573-1:2010 Class 1.2.1

ISO 8573-1:2010 refers to the standard document and its revision, the three digits refer to the purity classifications selected for solid particulate, water and total oil. Selecting an air purity class of 1.2.1 would specify the following air quality when operating at the standard's reference conditions :

#### Class 1 - Particulate

In each cubic metre of compressed air, the particulate count should not exceed 20,000 particles in the 0.1 - 0.5 micron size range, 400 particles in the 0.5 - 1 micron size range and 10 particles in the 1 - 5 micron size range.

#### Class 2 - Water

A pressure dewpoint (PDP) of -40°C or better is required and no liquid water is allowed.

#### Class 1 - Oil

In each cubic metre of compressed air, not more than 0.01mg of oil is allowed. This is a total level for liquid oil, oil aerosol and oil vapour.

## ISO8573-1:2010 Class zero

- **Class 0 does not mean zero contamination.**
- **Class 0 requires the user and the equipment manufacturer to agree contamination levels as part of a written specification.**
- **The agreed contamination levels for a Class 0 specification should be within the measurement capabilities of the test equipment and test methods shown in ISO8573 Pt 2 to Pt 9.**
- **The agreed Class 0 specification must be written on all documentation to be in accordance with the standard.**
- **Stating Class 0 without the agreed specification is meaningless and not in accordance with the standard.**
- **A number of compressor manufacturers claim that the delivered air from their oil-free compressors is in compliance with Class 0.**
- **If the compressor was tested in clean room conditions, the contamination detected at the outlet will be minimal. Should the same compressor now be installed in typical urban environment, the level of contamination will be dependent upon what is drawn into the compressor intake, rendering the Class 0 claim invalid.**
- **A compressor delivering air to Class 0 will still require purification equipment in both the compressor room and at the point of use for the Class 0 purity to be maintained at the application.**
- **Air for critical applications such as breathing, medical, food, etc typically only requires air quality to Class 2.2.1 or Class 2.1.1.**
- **Purification of air to meet a Class 0 specification is only cost effective if carried out at the point of use.**

## Introduction to the ATEX directive

### Explosive atmospheres

Directive 94/9/EC defines an explosive atmosphere as a mixture of:

- a) **flammable substances** – gases, vapours, mists or dusts
  - b) with **air**
  - c) under specific **atmospheric conditions**
  - d) in which, after ignition has occurred, combustion spreads to the entire flammable mixture
- (NB: with regard to dust, it may be that not all dust is combusted after ignition has occurred)

An atmosphere with the potential to become an explosive atmosphere during operating conditions and/or under the influence of the surroundings is defined as a **potentially explosive atmosphere**. Products covered by directive 94/9/EC are defined as intended for use in potentially explosive atmospheres.

### Harmonised European ATEX standard

The European Union has adopted two harmonised directives in the field of health and safety. The directives are known as ATEX 100a and ATEX 137.

Directive ATEX 100a (94/9/EC) lays down minimum safety requirements for products intended for use in potentially explosive atmospheres in European Union member states. Directive ATEX 137 (99/92/EC) defines minimum requirements for health and safety at the workplace, for working conditions and for the handling of products and materials in potentially explosive atmospheres. This directive also divides the workplace into **zones** and defines criteria by which products are **categorised** within these zones.

The table below describes the **zones** in an installation where there is a potential for explosive atmospheres. The **owner** of the installation must analyse and assess the area in which the explosive gas/dust mixture may occur, and if necessary must divide it into **zones**. This process of zoning then allows the correct plant and equipment to be selected for use in the area.

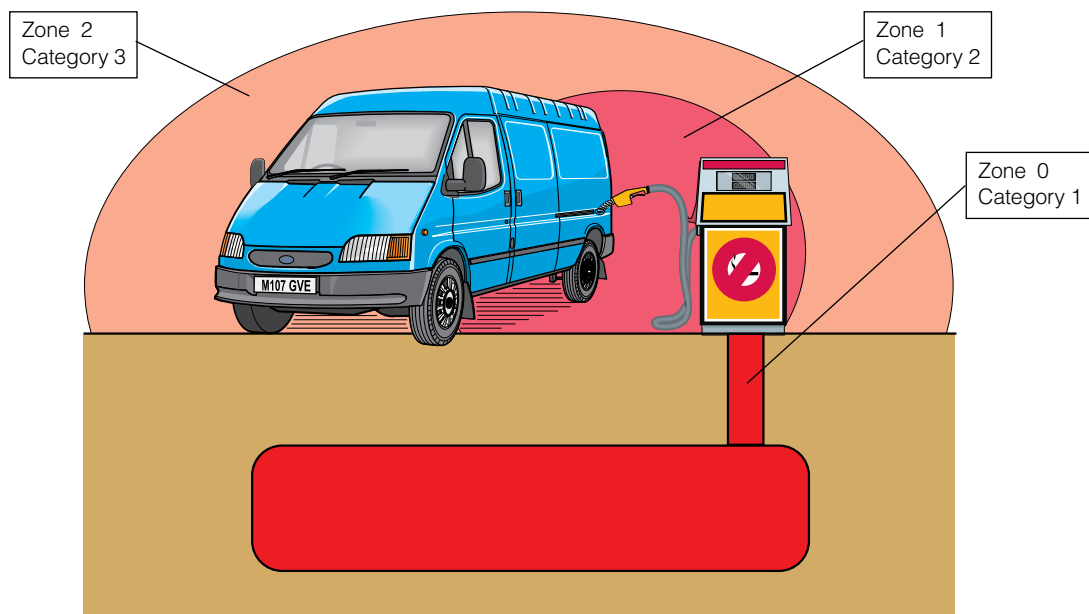

Zones		Presence of potentially explosive atmosphere	Type of risk
Gas G	Dust D		
0	20	Present continuously or for long periods	Permanent
1	21	Likely to occur in normal operation occasionally	Potential
2	22	Not likely to occur in normal operation but, if it does occur, will persist for a short period only	Minimal

The ATEX directive has been in force throughout the European Union since 1 July 2003, replacing the existing divergent national and European legislation relating to explosive atmospheres. Please note that for the first time, the directive covers mechanical, hydraulic and pneumatic equipment and not just electrical equipment as before.

With regard to the **Machinery directive** 98/37/EC, note that a number of external requirements in 94/9/EC refer to hazards arising from potentially explosive atmospheres, where the Machinery directive only contains general requirements relating to explosion safety (Annex I 1.5.7).

As a result, directive 94/9/EC (ATEX 100a) takes precedence over the Machinery directive with regard to explosion protection in potentially explosive atmospheres. The requirements in the Machinery directive are applicable to all other risks relating to machinery.

## P1D-T Pneumatic ISO Cylinders - Ø160 - Ø320 mm

### Levels of protection for the various equipment categories

The various equipment categories must be capable of operating in accordance with the manufacturer's operating specifications at defined levels of protection.

Level of protection	Category		Type of protection	Operating specifications
	Group I	Group II		
Very high	M1		Two independent means of protection or safety, ensuring that the equipment remains functional even in the event of two faults occurring independently of each other	The equipment remains energised and functional even with an explosive atmosphere present
Very high		1	Two independent means of protection or safety, ensuring that the equipment remains functional even in the event of two faults occurring independently of each other	The equipment remains energised and functional in zones 0, 1, 2 (G) and/or zones 20, 21, 22 (D)
High	M2		Protection suitable for normal operation and severe operating conditions	The equipment is de-energised in the event of an explosive atmosphere
High		2	Protection suitable for normal operation and frequent faults, or equipment in which faults normally have to be taken into account	The equipment remains energised and functional in zones 1, 2 (G) and/or zones 21, 22 (D)
Normal		3	Protection suitable for normal operation	The equipment remains energised and functional in zones 2 (G) and/or zones 22 (D)

### Definition of groups (EN 1127-1)

**Group I** Equipment intended for use in underground parts of mines as well as those parts of surface installations of such mines likely to be endangered by flammable vapours and/or flammable dusts.

**Group II** Equipment intended for use in other places exposed to explosive atmospheres.

Group	I mines, combustible vapours		II other potentially explosive atmospheres (gases, dust)					
	M1	M2	1		2		3	
Category								
Atmosphere*			G	D	G	D	G	D
Zone			0	20	1	21	2	22

G = gas and D = dust

### Temperature classes

Classification of flammable gases and vapours on the basis of ignition temperature

Temperature class	Ignition temperature °C
T1	Over 450
T2	(300) – 450
T3	(200) – 300
T4	(135) – 200
T5	(100) – 135
T6	(85) - 100

### Declaration of conformity

The product catalogues contain copies of the declaration of conformity demonstrating that the product meets the requirements of directive 94/9/EC.

The declaration is only valid in conjunction with the instructions contained in the installation manual relating to the safe use of the product throughout its service life.

The instructions relating to the conditions in the surrounding area are particularly important, as the certificate is invalidated if the instructions are found not to have been adhered to during operation of the product.

If there is any doubt as to the validity of the certificate of conformity, contact Parker Hannifin customer service.

### Operation, installation and maintenance

The installation manual of the product contains instructions relating to the safe storage, handling, operation and servicing of the product.

The manual is available in different languages, and can be downloaded from [www.parker.com/euro\\_pneumatic](http://www.parker.com/euro_pneumatic).

This document must be made accessible in a suitable place near where the product is installed. It is used as a reference for all personnel authorised to work with the product throughout its service life. We, the manufacturer, reserve the right to modify, extend or improve the installation manual in the interests of the users.

For more information about ATEX see EUs homepage: <http://europa.eu.int/comm/enterprise/atex/>

## Safety instructions for the P1D-T cylinder with accessories

### Supplementary safety instructions for installation of ATEX certified P1S cylinders.

The safety instructions in this document are valid for the ATEX certified P1D-T cylinders, bore 160 - 320mm, as per below with reference to the order code key in the product catalogue.

P1D-T\*\*\*MS-\*\*\*\*-EX

All strokes in the range 50 - 1000mm

### Serious, even fatal, damage or injury may be caused by the hot moving parts of the P1D-T cylinders in the presence of explosive gas mixtures and concentrations of dust.

All installation, connection, commissioning, servicing and repair work on P1D-T cylinders must be carried out by qualified personnel taking account of the following

- These instructions
- Markings on the cylinder
- All other planning documents, commissioning instructions and connection diagrams associated with the application.
- Provisions and requirements specific to the application
- National/international regulations (explosion protection, safety and accident prevention)

### Real life applications

P1D-T cylinders are designed to provide linear movement in industrial applications, and should only be used in accordance with the instructions in the technical specifications in the catalogue, and within the operating range indicated on the rating plate.

The cylinders meet the applicable standards and requirements of directive 94/9/EC (ATEX)

The cylinders must not be used underground in mines susceptible to firedamp and/or flammable dusts. The cylinders are intended for use in areas in which explosive atmospheres caused by gases, vapours or mists of flammable liquids, or air/dust mixtures may be expected to occur during normal use (infrequently)

### Checklist

Before using the cylinders in an Ex-area, you should check the following:

Do the specifications of the P1D-T cylinder match the Ex-classification of the area of use in accordance with directive 94/9/EC (previously ATEX 100a)

- Equipment group
- Ex-equipment category
- Ex-zone
- Temperature class
- Max. surface temperature

1. When installing the P1D-T cylinder, is it certain that there is no potentially explosive atmosphere, oil, acids, gases, vapours or radiation?
2. Is the ambient temperature as specified in the technical data in the catalogue at all times?
3. Is it certain that the P1D-T cylinder is adequately ventilated and that no forbidden additional heat is added?
4. Are all the driven mechanical components ATEX certified?
5. Check that the P1D-T cylinder is safely earthed.
6. Check that the P1D-T cylinder is supplied with compressed air. Explosive gas mixtures must not be used for driving the cylinder.
7. Check that the P1D-T cylinder is not equipped with a metal scraper ring (special version).

### Installation requirements in Ex-areas

- The temperature of the supply air must not exceed the ambient temperature.
- The P1D-T cylinder may be installed in any position.
- The P1D-T cylinder must not be installed where there is a risk of mechanical contact with any surrounding part or component.
- An air treatment unit must be attached to the inlet of the P1D-T cylinder.
- The P1D-T cylinder must be connected to earth at all times, through its support, a metallic tube or separate conductor.
- The outlet of the P1D-T cylinder must not be open within an Ex-area, but must be connected to the silencer or, preferably, piped and released outside the Ex-area.
- The P1D-T cylinder may only drive units that are ATEX certified.
- Ensure that the P1D-T cylinder is not exposed to forces greater than those permitted in accordance with the catalogue
- The P1D-T cylinder must be supplied with compressed air. Explosive gas mixtures must not be used
- P1D-T cylinders with metal scraper rings must not be used in Ex-areas

### Inspecting cylinders during operation

The P1D-T cylinder must be kept clean on the outside, and a layer of dust/dirt thicker than 1 mm must never be allowed to form. Inspect and verify that the cylinder, with attachments, compressed air fittings, hoses, tubes, etc. meet the standards of "safe" installation.

### Spare parts

Only spare parts, kits etc. supplied by Parker Hannifin may be used for repair and maintenance of the P1D-T cylinders.

### Marking of ATEX certified P1D-T cylinders

The ATEX certified P1D-T cylinders, bore 160 - 320mm, as per below with reference to the order code key in the product catalogue have an ATEX certification marking as shown further below.

P1D-T\*\*\*MS-\*\*\*\*-EX

All strokes in the range 50 - 1000mm



- CE** Communauté Européenne = EU  
CE on the product shows that Parker Hannifin products meet one or more EU directives
- Ex** Ex means that this product is intended for use in potentially explosive atmospheres
- II** Stands for the equipment group (I = mines and II = other hazardous areas)
- 2GD** Stands for equipment category 2G means the equipment can be used in zones 1 and 2 where there is a risk involving gases, vapours or mists of combustible liquids and 2D in zones 21 and 22 where there is a risk involving dusts. 2GD Means the equipment can be used in zones 1, 2, 21 and 22.
- c** Safe design (prEN 13463-5)
- T4** If equipment is in temperature class T4, the maximum surface temperature must not exceed 135 °C. (To guarantee this, the product has been tested to ensure that the maximum is 130 °C. This provides a safety margin of 5 °K.)
- 120 °C** Maximum permitted surface temperature on P1D-S cylinder in atmospheres containing potentially explosive dusts.

### Supplementary safety instructions for P8S-GPFLX/EX sensors installed in Ex-areas

Serious, even fatal, damage or injury may be caused by the hot moving parts of the P1D-T cylinders in the presence of explosive gas mixtures and concentrations of dust.

#### Instructions for use

##### Safety instructions

- Cylinder sensor ATEX classed for category II3G and II3D
- Ambient temperature  $T_a = -20\text{ °C}$  to  $+45\text{ °C}$
- Temperature class T4, or max. surface temperature of  $T = 135\text{ °C}$
- Protection class IP67
- Read installation instructions before startup
- Installation, connection and commissioning must be carried out by trained personnel

##### Applications

- This sensor is designed for use in the T-groove of cylinders, and detects the magnetic field in potentially explosive areas. The sensor can only be installed in the T-groove of these cylinders.
- The sensor may also be installed on round cylinders by means of the following attachments:

**P8S-TMC01** Suitable for P1S and P1A diameter 10 - 25 mm

**P8S-TMC02** Suitable for P1S diameter 32 - 63 mm

**P8S-TMC03** Suitable for P1S diameter 80 - 125 mm

The following data applies to these attachments:

- Ambient temperature  $T_a = 0\text{ °C}$  to  $45\text{ °C}$
- Low energy absorption to EN 50 021
- The sensor may also be installed on tie-rod cylinders or profile cylinders by means of this attachment:

**P8S-TMAOX** Suitable for P1D-T diameter 32 - 125 mm, P1E-T diameter 160 – 200 mm and C41 diameter 160 – 200 mm

##### Installation

General: The sensor must be protected from UV radiation. The cable must be installed such that it is protected from external influences, for example it may be necessary to attach an external strain relief to the cable.

##### Technical data for sensor

Operating voltage  $U_b = 18$  to  $30\text{ V DC}$

Max. load current  $I_a \leq 70\text{ mA}$

Ambient temperature:  $-20\text{ °C}$  to  $45\text{ °C}$

##### Commissioning

When connecting the sensor to a power source, please pay attention to the following



- a) the load data (operating voltage, continuous load current)
- b) the wiring diagram for the sensor

##### Maintenance

Our P8S-GPFLX/EX cylinder sensor is maintenance free, but the cable connections should be checked at regular intervals.

The sensor must be protected from UV radiation. The sensor must be kept clean on the outside, and a layer of dirt thicker than 1 mm must never be allowed to form. Strong solvents should not be used for cleaning as they may damage the sensor.

### P8S-GPFLX/EX cylinder sensor

  **II3G EEx nA II T4X**  
**II3D 135 °C IP67**



Communauté Européenne = EU

CE on the product shows that Parker Hannifin products meet one or more EU directives



Ex means that this product is intended for use in potentially explosive atmospheres

**II**

Stands for the equipment group (I = mines and II = other hazardous areas)

**3G**

Stands for the equipment category 3G means the equipment can be used in zone 2 where there is a risk involving gases, vapours or mists of combustible liquids

**EEx**

EEx means that this is an electrical product intended for use in Ex-areas

**nA II**

n Not ignitable to EN50021, A Explosion group tested with acetone, ethanol, toluene and xylene; II Not for use in the mining industry

**T4 X**

If equipment is in temperature class T4, the maximum surface temperature must not exceed  $135\text{ °C}$ . (To guarantee this, the product has been tested to ensure that the maximum is  $130\text{ °C}$ . This provides a safety margin of  $5\text{ °C}$ .) X Must be installed in accordance with the installation manual

**3D**

Stands for equipment category 3D in zone 22 where there is a risk involving dusts.

**135 °C**

Maximum permitted surface temperature on the motor in atmospheres containing potentially explosive dusts.

**IP67**

Satisfies protection class IP67

### Components such as cylinder attachments, tube fittings, tubes, etc.

#### Components

Parker Hannifin guarantees that our cylinder mountings, tube fittings, tubes, etc. are not ignition sources and are therefore not subject to the provisions of the ATEX directive.

A component means any item essential to the safe functioning of equipment and protective systems but with no autonomous function.

Components intended for incorporation into equipment or protective systems which are accompanied by an attestation of conformity with the ATEX directive, including a statement of their characteristics and how they must be incorporated into products, are considered to conform to the applicable provisions of directive 94/9/EC. Ex-components as defined in the European standard EN 50014 are components in the sense of the ATEX directive 94/9/EC as well. Components must not have the CE marking affixed unless otherwise required by other directives.

Examples of components:

- terminals
- push buttons assemblies
- relays
- empty flameproof enclosures
- ballasts for fluorescent lamps
- meters (e.g. moving coil)
- encapsulated relays and contactors, with terminals and/or flying leads



# Parker Worldwide

## Europe, Middle East, Africa

**AE – United Arab Emirates,**  
Dubai

Tel: +971 4 8127100  
parker.me@parker.com

**AT – Austria,** Wiener Neustadt

Tel: +43 (0)2622 23501-0  
parker.austria@parker.com

**AT – Eastern Europe,** Wiener  
Neustadt

Tel: +43 (0)2622 23501 900  
parker.easteurope@parker.com

**AZ – Azerbaijan,** Baku

Tel: +994 50 2233 458  
parker.azerbaijan@parker.com

**BE/LU – Belgium,** Nivelles

Tel: +32 (0)67 280 900  
parker.belgium@parker.com

**BY – Belarus,** Minsk

Tel: +375 17 209 9399  
parker.belarus@parker.com

**CH – Switzerland,** Etoy

Tel: +41 (0)21 821 87 00  
parker.switzerland@parker.com

**CZ – Czech Republic,** Klecany

Tel: +420 284 083 111  
parker.czechrepublic@parker.com

**DE – Germany,** Kaarst

Tel: +49 (0)2131 4016 0  
parker.germany@parker.com

**DK – Denmark,** Ballerup

Tel: +45 43 56 04 00  
parker.denmark@parker.com

**ES – Spain,** Madrid

Tel: +34 902 330 001  
parker.spain@parker.com

**FI – Finland,** Vantaa

Tel: +358 (0)20 753 2500  
parker.finland@parker.com

**FR – France,** Contamine s/Arve

Tel: +33 (0)4 50 25 80 25  
parker.france@parker.com

**GR – Greece,** Athens

Tel: +30 210 933 6450  
parker.greece@parker.com

**HU – Hungary,** Budapest

Tel: +36 23 885 475  
parker.hungary@parker.com

**IE – Ireland,** Dublin

Tel: +353 (0)1 466 6370  
parker.ireland@parker.com

**IT – Italy,** Corsico (MI)

Tel: +39 02 45 19 21  
parker.italy@parker.com

**KZ – Kazakhstan,** Almaty

Tel: +7 7272 505 800  
parker.easteurope@parker.com

**NL – The Netherlands,** Oldenzaal

Tel: +31 (0)541 585 000  
parker.nl@parker.com

**NO – Norway,** Asker

Tel: +47 66 75 34 00  
parker.norway@parker.com

**PL – Poland,** Warsaw

Tel: +48 (0)22 573 24 00  
parker.poland@parker.com

**PT – Portugal,** Leca da Palmeira

Tel: +351 22 999 7360  
parker.portugal@parker.com

**RO – Romania,** Bucharest

Tel: +40 21 252 1382  
parker.romania@parker.com

**RU – Russia,** Moscow

Tel: +7 495 645-2156  
parker.russia@parker.com

**SE – Sweden,** Spånga

Tel: +46 (0)8 59 79 50 00  
parker.sweden@parker.com

**SK – Slovakia,** Banská Bystrica

Tel: +421 484 162 252  
parker.slovakia@parker.com

**SL – Slovenia,** Novo Mesto

Tel: +386 7 337 6650  
parker.slovenia@parker.com

**TR – Turkey,** Istanbul

Tel: +90 216 4997081  
parker.turkey@parker.com

**UA – Ukraine,** Kiev

Tel +380 44 494 2731  
parker.ukraine@parker.com

**UK – United Kingdom,** Warwick

Tel: +44 (0)1926 317 878  
parker.uk@parker.com

**ZA – South Africa,** Kempton Park

Tel: +27 (0)11 961 0700  
parker.southafrica@parker.com

## North America

**CA – Canada,** Milton, Ontario

Tel: +1 905 693 3000

**US – USA,** Cleveland

Tel: +1 216 896 3000

## Asia Pacific

**AU – Australia,** Castle Hill

Tel: +61 (0)2-9634 7777

**CN – China,** Shanghai

Tel: +86 21 2899 5000

**HK – Hong Kong**

Tel: +852 2428 8008

**IN – India,** Mumbai

Tel: +91 22 6513 7081-85

**JP – Japan,** Tokyo

Tel: +81 (0)3 6408 3901

**KR – South Korea,** Seoul

Tel: +82 2 559 0400

**MY – Malaysia,** Shah Alam

Tel: +60 3 7849 0800

**NZ – New Zealand,** Mt Wellington

Tel: +64 9 574 1744

**SG – Singapore**

Tel: +65 6887 6300

**TH – Thailand,** Bangkok

Tel: +662 186 7000-99

**TW – Taiwan,** Taipei

Tel: +886 2 2298 8987

## South America

**AR – Argentina,** Buenos Aires

Tel: +54 3327 44 4129

**BR – Brazil,** Sao Jose dos Campos

Tel: +55 800 727 5374

**CL – Chile,** Santiago

Tel: +56 2 623 1216

**MX – Mexico,** Apodaca

Tel: +52 81 8156 6000

European Product Information Centre

Free phone: 00 800 27 27 5374

(from AT, BE, CH, CZ, DE, DK, EE, ES, FI,  
FR, IE, IL, IS, IT, LU, MT, NL, NO, PL, PT, RU,  
SE, SK, UK, ZA)

### Parker Hannifin Ltd.

Tachbrook Park Drive  
Tachbrook Park,  
Warwick, CV34 6TU  
United Kingdom  
Tel.: +44 (0) 1926 317 878  
Fax: +44 (0) 1926 317 855  
parker.uk@parker.com  
www.parker.com

