

Inter-lock Tail

in!



004N



Swaged Ferrule
(skive)

103

0013



Swaged Ferrule
(skive)

113



0370H



NPTF Male 60° cone

104



0350H



BSP Male Parallel 60°
cone

104

0050H



BSP Female 60° cone
Thrust Wire

105

0150H



BSP 90° Swept Elbow
60° cone Thrust Wire

105

0250H



BSP 45° Swept Elbow
60° cone Thrust Wire

106



0850H



JIC Male 74° cone

106



0900H



JIC Female 74° cone
Thrust Wire

107

0950H



JIC 90° Swept Elbow
74° cone Thrust Wire

107

1000H



JIC 45° Swept Elbow
74° cone Thrust Wire

108



0450H



Metric Male 24° Seat
Heavy

108

0084H

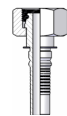

Metric Female 24°
Seat Heavy

109



0184H



90° Metric Swept El-
bow 24° Seat Heavy

109

0284H



45° Metric Swept El-
bow 24° Seat Heavy

101



S050H



ORFS Female

110

S05TH



ORFS Female Back
Hexagon

111

S150H



ORFS 90° Swept Elbow

111

S250H



ORFS 45° Swept Elbow

112

S350H

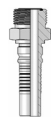

ORFS Male

112



1250H



Straight SAE Flange 3000 PSI

113

1050H



90° SAE Flange 3000 PSI

113

1150H



45° SAE Flange 3000 PSI

114

1300H



Straight SAE Flange 6000 PSI

114

1100H



90° SAE Flange 6000 PSI

115

1200H



45° SAE Flange 6000 PSI

115

Super CAT

130SH



Straight 'CAT' Flange

116

110SH



90° 'CAT' Flange

116

120SH



45° 'CAT' Flange

117

004N

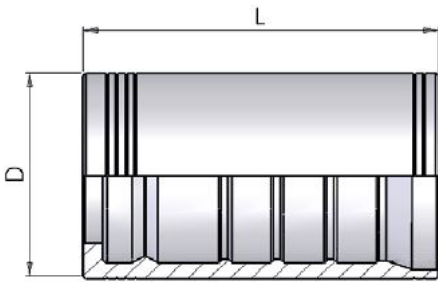

Swaged Ferrule (Skive)

Part number	Hose I.D.		Dimensions		Skive
	in	mm	D	L	Lenght
004N-12	3/4	19.0	38	60	52/15
004N-16	1	25.4	46	74.5	64/17
004N-20	1.1/4	31.8	55	88	74/22
004N-24	1.1/2	38.1	62	94	81/22,5
004N-32	2	50.8	78	99	85/30

0013

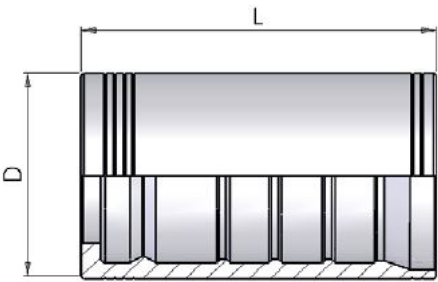

Swaged Ferrule (Skive)

Part number	Hose I.D.		Dimensions		Skive
	in	mm	D	L	Lenght
0013-20	1.1/4	31.8	60	88	74/22
0013-24	1.1/2	38.1	67	94	81/22,5
0013-32	2	50.8	84.5	99	85/30

0370H

NPTF Male 60° Cone

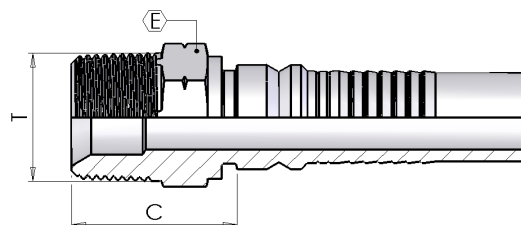

Part number	Hose I.D.		Dimensions			
	in	mm	Dash size	Thread T	Hex E	Cut-Off C
0370H12-12	3/4	19.0	12	3/4-14	27	35
0370H16-16	1	25.4	16	1-11.1/2	36	41
0370H20-20	1.1/4	31.8	20	1.1/4-11.1/2	46	44
0370H24-24	1.1/2	38.1	24	1.1/2-11.1/2	50	47
0370H32-32	2	50.8	32	2-11.1/2	65	54

0350H

BSP Male Parallel 60° Cone

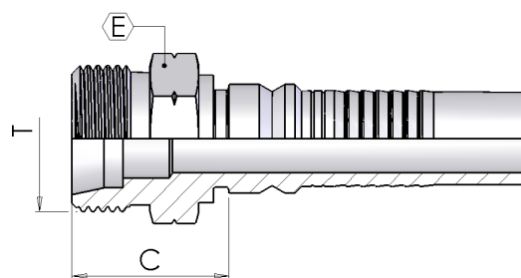

Part number	Hose I.D.		Dimensions			
	in	mm	Dash size	Thread T	Hex E	Cut-Off C
0350H12-12	3/4	19.0	12	3/4-14	32	33
0350H12-16	3/4	19.0	12	1-11	41	36
0350H16-16	1	25.4	16	1-11	41	37
0350H16-20	1	25.4	16	1.1/4-11	50	41
0350H20-20	1.1/4	31.8	20	1.1/4-11	50	42
0350H24-24	1.1/2	38.1	24	1.1/2-11	55	44
0350H32-32	2	50.8	32	2-11	70	53

0050H

BSP Female 60° Cone - Thrust Wire

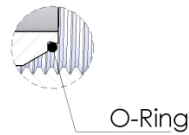
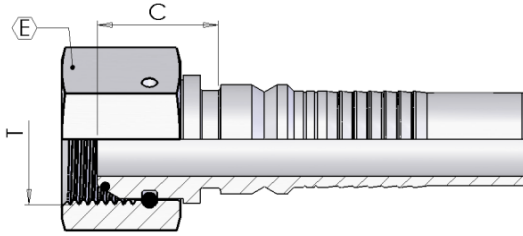

(*)- BSP female with O-Ring

Part number	Hose I.D.		Dimensions			
	in	mm	Dash size	Thread T	Hex E	Cut-Off C
(*) 0050H12-12	3/4	19.0	12	3/4-14	32	23
(*) 0050H12-16	3/4	19.0	12	1-11	38	25
(*) 0050H16-16	1	25.4	16	1-11	38	26
(*) 0050H20-20	1.1/4	31.8	20	1.1/4-11	50	29
(*) 0050H20-24	1.1/4	31.8	20	1.1/2-11	55	31
(*) 0050H24-24	1.1/2	38.1	24	1.1/2-11	55	31
(*) 0050H32-32	2	50.8	32	2-11	70	30

0150H

BSP 90° Swept Elbow 60° Cone - Thrust Wire

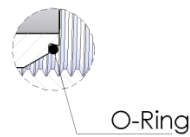
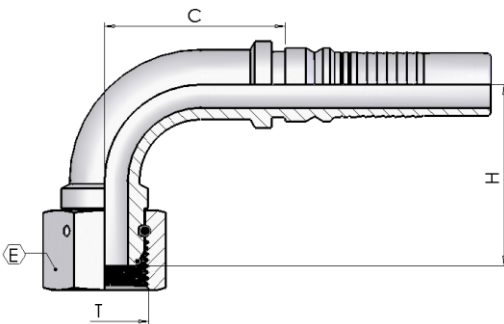

(*)- BSP female with O-Ring

Part number	Hose I.D.		Dimensions				
	in	mm	Dash size	Thread T	Hex E	Drop H	Cut-Off C
(*) 0150H12-12	3/4	19.0	12	3/4-14	32	57	54
(*) 0150H16-16	1	25.4	16	1-11	38	70	73
(*) 0150H16-20	1	25.4	16	1.1/4-11	50	76	73
(*) 0150H20-20	1.1/4	31.8	20	1.1/4-11	50	83	93
(*) 0150H24-24	1.1/2	38.1	24	1.1/2-11	55	104	111
(*) 0150H32-32	2	50.8	32	2-11	70	135	122

0250H

BSP 45° Swept Elbow 60° Cone - Thrust Wire

(*)- BSP female with O-Ring

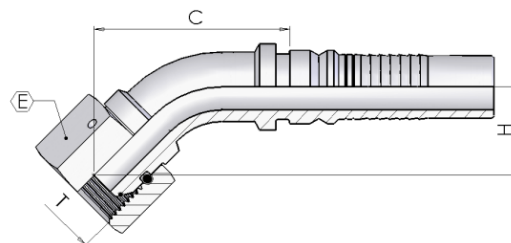
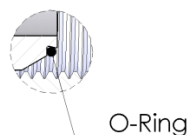

Part number	Hose I.D.		Dimensions				
	in	mm	Dash size	Thread T	Hex E	Drop H	Cut-Off C
(*) 0250H12-12	3/4	19.0	12	3/4-14	32	28	84
(*) 0250H16-16	1	25.4	16	1-11	38	38	112
(*) 0250H20-20	1.1/4	31.8	20	1.1/4-11	50	41	137
(*) 0250H24-24	1.1/2	38.1	24	1.1/2-11	55	54	166
(*) 0250H32-32	2	50.8	32	2-11	70	70	195

0850H

JIC Male 74° Cone

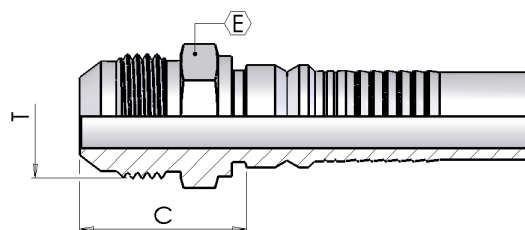

Part number	Hose I.D.		Dimensions			
	in	mm	Dash size	Thread T	Hex E	Cut-Off C
0850H12-12	3/4	19.0	12	1.1/16-12	27	36
0850H16-16	1	25.4	16	1.5/16-12	34	40
0850H20-20	1.1/4	31.8	20	1.5/8-12	42	44
0850H24-24	1.1/2	38.1	24	1.7/8-12	50	49
0850H32-32	2	50.8	32	2.1/2-12	65	61

0900H

JIC Female 74° Cone - Thrust Wire

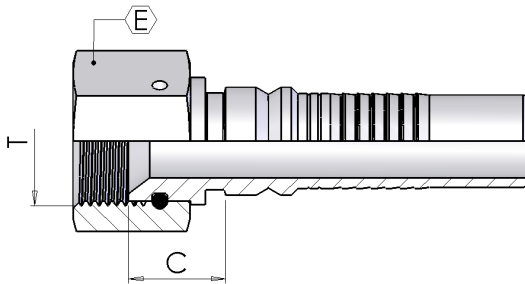

Part number	Hose I.D.		Dimensions			
	in	mm	Dash size	Thread T	Hex E	Cut-Off C
0900H12-12	3/4	19.0	12	1.1/16-12	32	19
0900H12-16	3/4	19.0	12	1.5/16-12	41	22
0900H16-16	1	25.4	16	1.5/16-12	41	23
0900H20-20	1.1/4	31.8	20	1.5/8-12	50	26
0900H24-24	1.1/2	38.1	24	1.7/8-12	55	29
0900H32-32	2	50.8	32	2.1/2-12	70	30

0950H

JIC 90° Swept Elbow 74° Cone - Thrust Wire

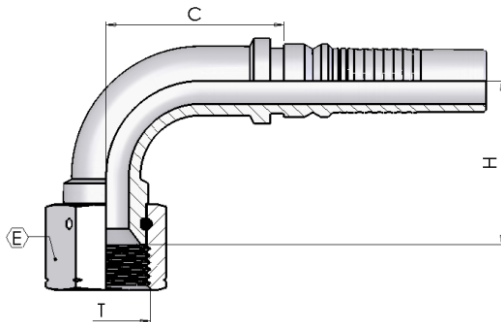

Part number	Hose I.D.		Dimensions				
	in	mm	Dash size	Thread T	Hex E	Drop H	Cut-Off C
0950H12-12	3/4	19.0	12	1.1/16-12	32	54	54
0950H12-16	3/4	19.0	12	1.5/16-12	41	62	54
0950H16-16	1	25.4	16	1.5/16-12	41	66	77
0950H20-20	1.1/4	31.8	20	1.5/8-12	50	86	92
0950H24-24	1.1/2	38.1	24	1.7/8-12	55	100	112
0950H32-32	2	50.8	32	2.1/2-12	70	134	121

1000H

JIC 45° Swept Elbow 74° Cone - Thrust Wire

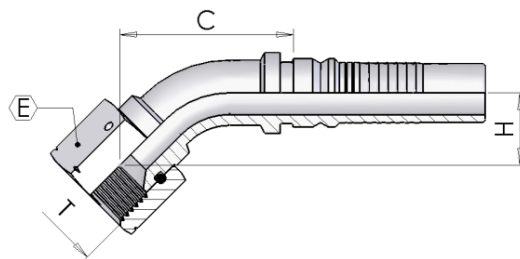

Part number	Hose I.D.		Dimensions				
	in	mm	Dash size	Thread T	Hex E	Drop H	Cut-Off C
1000H12-12	3/4	19.0	12	1.1/16-12	32	28	85
1000H12-16	3/4	19.0	12	1.5/16-12	41	32	88
1000H16-16	1	25.4	16	1.5/16-12	41	36	113
1000H20-20	1.1/4	31.8	20	1.5/8-12	50	50	133
1000H24-24	1.1/2	38.1	24	1.7/8-12	55	49	165
1000H32-32	2	50.8	32	2.1/2-12	70	67	194

0450H

Metric Male 24° - Seat Heavy

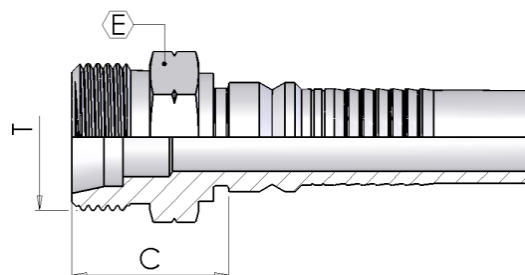

Part number	Hose I.D.		Dimensions				
	in	mm	Dash size	Thread T	Erm	Hex E	Cut-Off C
0450H12-36	3/4	19.0	12	M36-2	25	36	36
0450H16-42	1	25.4	16	M42-2	30	46	39
0450H20-52	1.1/4	31.8	20	M52-2	38	55	42
0450H24-52	1.1/2	38.1	24	M52-2	38	55	42.5

0084H

**Metric Female 24°
- Seat Heavy**

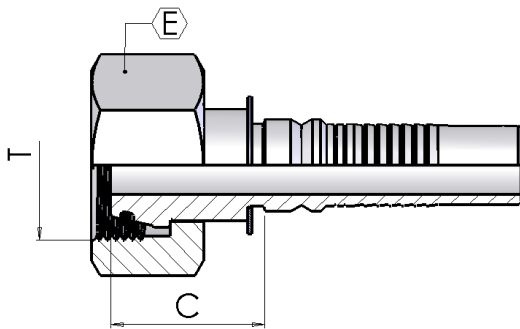

Part number	Hose I.D.		Dimensions				
	in	mm	Dash size	Thread T	Erm	Hex E	Cut-Off C
0084H12-36	3/4	19.0	12	M36-2	25	46	37
0084H16-36	1	25.4	16	M36-2	25	46	38
0084H16-42	1	25.4	16	M42-2	30	50	41
0084H20-52	1.1/4	31.8	20	M52-2	38	60	41
0084H24-52	1.1/2	38.1	24	M52-2	38	60	42

0184H

**90° Metric Swept Elbow 24°
- Seat Heavy**

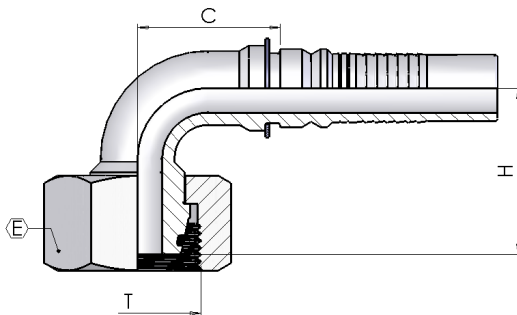

Part number	Hose I.D.		Dimensions					
	in	mm	Dash size	Thread T	Erm	Hex E	Drop H	Cut-Off C
0184H12-36	3/4	19.0	12	M36-2	25	46	58	55
0184H16-36	1	25.4	16	M36-2	25	46	68	75
0184H16-42	1	25.4	16	M42-2	30	50	69	74
0184H20-52	1.1/4	31.8	20	M52-2	38	60	81	94

0284H

45° Metric Swept Elbow 24° - Seat Heavy

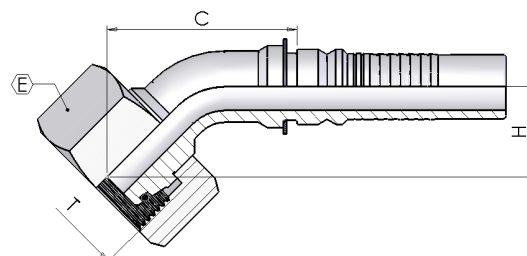

Part number	Hose I.D.		Dimensions					
	in	mm	Dash size	Thread T	Erm	Hex E	Drop H	Cut-Off C
0284H12-36	3/4	19.0	12	M36-2	25	46	31	94
0284H16-36	1	25.4	16	M36-2	25	46	34	110
0284H16-42	1	25.4	16	M42-2	30	50	33	112
0284H20-52	1.1/4	31.8	20	M52-2	38	60	81	93

S050H

ORFS Female

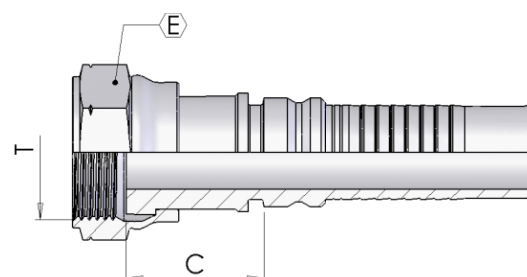

Part number	Hose I.D.		Dimensions			
	in	mm	Dash size	Thread T	Hex E	Cut-Off C
S050H12-14	3/4	19.0	12	1.3/16-12	36	33
S050H16-15	1	25.4	16	1.7/16-12	41	37
S050H16-21	1	25.4	16	1.11/16-12	50	35.5
S050H20-21	1.1/4	31.8	20	1.11/16-12	50	37
S050H20-32	1.1/4	31.8	20	2-12	60	36.7
S050H24-32	1.1/2	38.1	24	2-12	60	41

S05TH

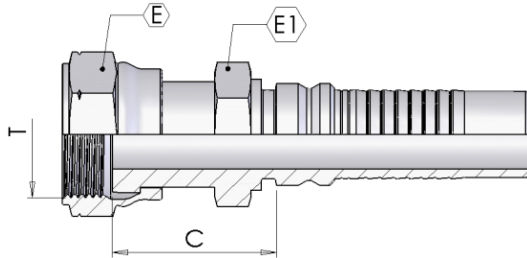

ORFS Female Back Hexagon

Part number	Hose I.D.		Dimensions				
	in	mm	Dash size	Thread T	Hex E E1		Cut-Off C
S05TH12-14	3/4	19.0	12	1.3/16-12	36	30	39
S05TH16-15	1	25.4	16	1.7/16-12	41	36	47
S05TH20-21	1.1/4	31.8	20	1.11/16-12	50	46	50

S150H

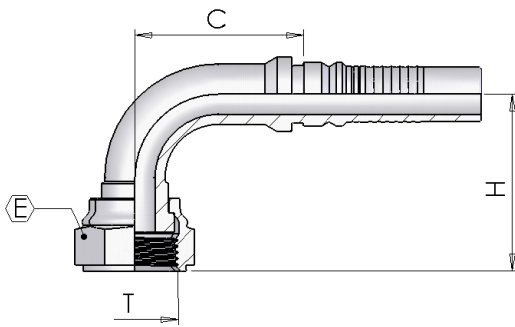

ORFS 90° Swept Elbow

Part number	Hose I.D.		Dimensions				
	in	mm	Dash size	Thread T	Hex E	Drop H	Cut-Off C
S150H12-14	3/4	19.0	12	1.3/16-12	36	49	54
S150H16-15	1	25.4	16	1.7/16-12	41	66	69
S150H20-21	1.1/4	31.8	20	1.11/16-12	50	80	87
S150H24-32	1.1/2	38.1	24	2-12	60	102	111

S250H

ORFS 45° Swept Elbow

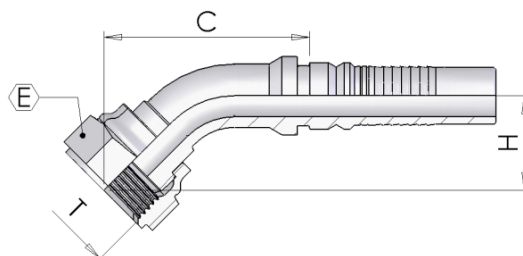

Part number	Hose I.D.		Dimensions				
	in	mm	Dash size	Thread T	Hex E	Drop H	Cut-Off C
S250H12-14	3/4	19.0	12	1.3/16-12	36	23	84
S250H16-15	1	25.4	16	1.7/16-12	41	33	107
S250H20-21	1.1/4	31.8	20	1.11/16-12	50	37	130
S250H24-32	1.1/2	38.1	24	2-12	60	50	165

Dado Libero

S350H

ORFS Male

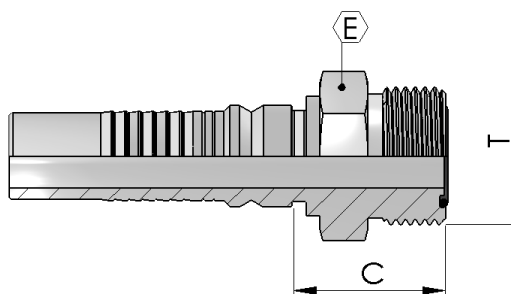

Part number	Hose I.D.		Dimensions			
	in	mm	Dash size	Thread T	Hex E	Cut-Off C
S350H12-14	3/4	19.0	12	1.3/16-12	32	34
S350H16-15	1	25.4	16	1.7/16-12	38	35
S350H20-21	1.1/4	31.8	20	1.11/16-12	46	36

1250H

Straight SAE Flange 3000 PSI

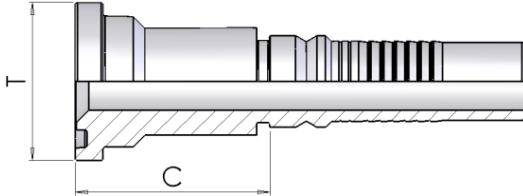

Part number	Hose I.D.		Dimensions			
	in	mm	Dash size	Flange		Cut-Off C
				T	mm	
1250H12-12	3/4	19.0	12	3/4	38.1	47
1250H12-16	3/4	19.0	12	1	44.5	50
1250H16-16	1	25.4	16	1	44.5	52
1250H16-20	1	25.4	16	1.1/4	50.8	55
1250H20-20	1.1/4	31.8	20	1.1/4	50.8	56
1250H20-24	1.1/4	31.8	20	1.1/2	60.3	59
1250H24-24	1.1/2	38.1	24	1.1/2	60.3	60
1250H24-32	1.1/2	38.1	24	2	71.4	65
1250H32-32	2	50.8	32	2	71.4	67

1050H

90° SAE Flange 3000 PSI

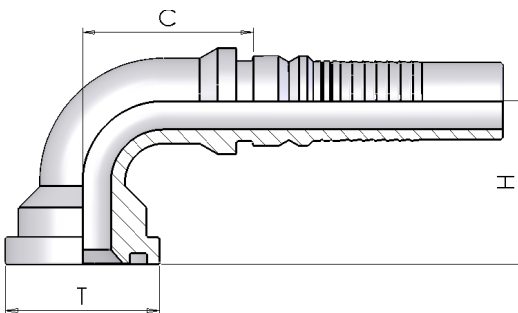

Part number	Hose I.D.		Dimensions				
	in	mm	Dash size	Flange		Drop H	Cut-Off C
				T	mm		
1050H12-12	3/4	19.0	12	3/4	38.1	52	52
1050H12-16	3/4	19.0	12	1	44.5	56	55
1050H16-16	1	25.4	16	1	44.5	65	73
1050H16-20	1	25.4	16	1.1/4	50.8	71	69
1050H20-20	1.1/4	31.8	20	1.1/4	50.8	78	93
1050H20-24	1.1/4	31.8	20	1.1/2	60.3	80	97
1050H24-24	1.1/2	38.1	24	1.1/2	60.3	95	100
1050H24-32	1.1/2	38.1	24	2	71.4	101	134
1050H32-32	2	50.8	32	2	71.4	121	122

1150H

45° SAE Flange 3000 PSI

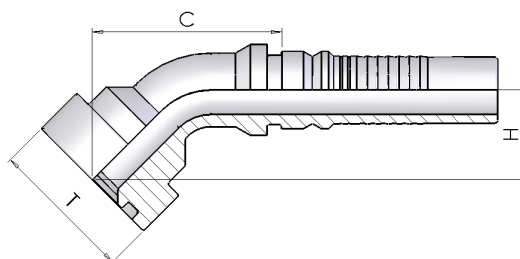

Part number	Hose I.D.		Dimensions				
	in	mm	Dash size	Flange T	mm	Drop H	Cut-Off C
1150H12-12	3/4	19.0	12	3/4	38.1	25	81
1150H12-16	3/4	19.0	12	1	44.5	28	86
1150H16-16	1	25.4	16	1	44.5	35	107
1150H16-20	1	25.4	16	1.1/4	50.8	37	113
1150H20-20	1.1/4	31.8	20	1.1/4	50.8	37	136
1150H20-24	1.1/4	31.8	20	1.1/2	60.3	40	136
1150H24-24	1.1/2	38.1	24	1.1/2	60.3	44	159
1150H24-32	1.1/2	38.1	24	2	71.4	47	159
1150H32-32	2	50.8	32	2	71.4	56	182

1300H

Straight SAE Flange 6000 PSI

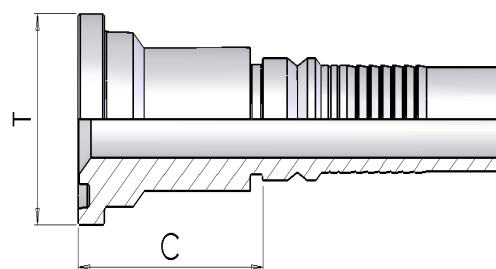

Part number	Hose I.D.		Dimensions			
	in	mm	Dash size	Flange T	mm	Cut-Off C
1300H12-12	3/4	19.0	12	3/4	41.3	51
1300H12-16	3/4	19.0	12	1	47.6	57
1300H16-12	1	25.4	16	3/4	41.3	52
1300H16-16	1	25.4	16	1	47.6	59
1300H16-20	1	25.4	16	1.1/4	54	66
1300H20-16	1.1/4	31.8	20	1	47.6	60
1300H20-20	1.1/4	31.8	20	1.1/4	54	67
1300H20-24	1.1/4	31.8	20	1.1/2	63.5	73
1300H24-20	1.1/2	38.1	24	1.1/4	54	75
1300H24-24	1.1/2	38.1	24	1.1/2	63.5	74
1300H24-32	1.1/2	38.1	24	2	79.4	82
1300H32-32	2	50.8	32	2	79.4	84

1100H

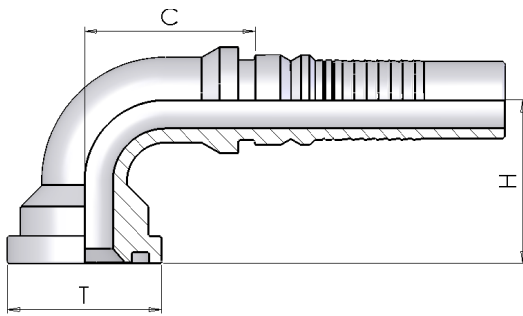

90° SAE Flange 6000 PSI

Part number	Hose I.D.		Dash size	Dimensions			
	in	mm		Flange T	mm	Drop H	Cut-Off C
1100H12-12	3/4	19.0	12	3/4	41.3	55	53
1100H12-16	3/4	19.0	12	1	47.6	63	52
1100H16-12	1	25.4	16	3/4	41.3	66	73
1100H16-16	1	25.4	16	1	47.6	72	74
1100H16-20	1	25.4	16	1.1/4	54	79.5	73
1100H20-16	1.1/4	31.8	20	1	47.6	80	93
1100H20-20	1.1/4	31.8	20	1.1/4	54	84,5	93
1100H20-24	1.1/4	31.8	20	1.1/2	63.5	90	98
1100H24-24	1.1/2	38.1	24	1.1/2	63.5	101	114
1100H24-32	1.1/2	38.1	24	2	79.4	115	115
1100H32-32	2	50.8	32	2	79.4	138	124

1200H

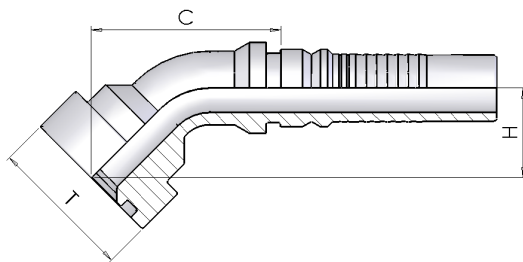

45° SAE Flange 6000 PSI

Part number	Hose I.D.		Dash size	Dimensions			
	in	mm		Flange T	mm	Drop H	Cut-Off C
1200H12-12	3/4	19.0	12	3/4	41.3	28	85
1200H12-16	3/4	19.0	12	1	47.6	34	88
1200H16-12	1	25.4	16	3/4	41.3	35	107
1200H16-16	1	25.4	16	1	47.6	34	112
1200H16-20	1	25.4	16	1.1/4	54	40	117
1200H20-16	1.1/4	31.8	20	1	47.6	42	117
1200H20-20	1.1/4	31.8	20	1.1/4	54	43	139
1200H20-24	1.1/4	31.8	20	1.1/2	63.5	48	144
1200H24-24	1.1/2	38.1	24	1.1/2	63.5	50	167
1200H24-32	1.1/2	38.1	24	2	79.4	64	166
1200H32-32	2	50.8	32	2	79.4	72	200

130SH

Straight 'CAT' Flange

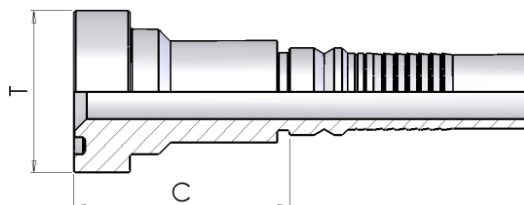

Part number	Hose I.D.		Dash size	Dimensions		Cut-Off C
	in	mm		Flange T	mm	
130SH12-12	3/4	19.0	12	3/4	41.3	55
130SH12-16	3/4	19.0	12	1	47.6	62
130SH16-16	1	25.4	16	1	47.6	63
130SH16-20	1	25.4	16	1.1/4	54	70
130SH20-20	1.1/4	31.8	20	1.1/4	54	71
130SH24-24	1,1/2	38.1	24	1.1/2	64	78

110SH

90° 'CAT' Flange

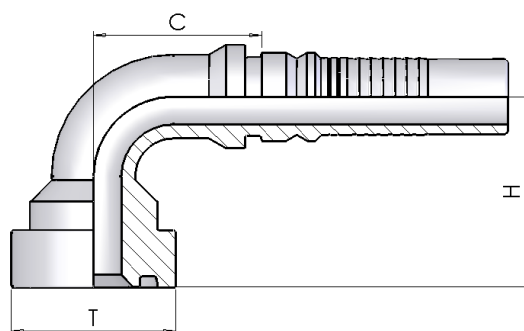

Part number	Hose I.D.		Dash size	Dimensions		Drop H	Cut-Off C
	in	mm		Flange T	mm		
110SH12-12	3/4	19.0	12	3/4	41.3	62	51
110SH16-16	1	25.4	16	1	47.6	75	73.2
110SH16-20	1	25.4	16	1.1/4	54	82	74
110SH20-20	1.1/4	31.8	20	1.1/4	54	89	93
110SH24-24	1,1/2	38.1	24	1.1/2	63.5	100	115

120SH

45° 'CAT' Flange

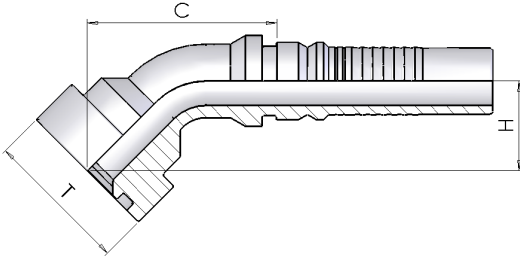

Part number	Hose I.D.		Dimensions				
	in	mm	Dash size	Flange T	mm	Drop H	Cut-Off C
120SH12-12	3/4	19.0	12	3/4	41.3	30	89
120SH16-16	1	25.4	16	1	47.6	38	115
120SH20-20	1.1/4	31.8	20	1.1/4	54	47	142
120SH24-24	1,1/2	38.1	24	1.1/2	63.5	52	169