

# Flowmeters & Monitors

Brochure: FDHB115GB3



# Flowmeters & Monitors

LoFlow – Oil, Water & Air Flowmeters



- Easy to read, permanent printed scales.
- Large scale definition for precise measurement.
- Easy panel mounting assembly.
- Negligible pressure drop characteristics.
- 10 bar pressure rating.
- Simple to use.

## SPECIFICATION

### Construction:

Body Grillon TR55.  
Back Body Half ABS 7020.  
Ball Retainer ABS 7020.  
Back Panel PVC.  
Float See below.

### Maximum Working Pressure:

10 bar.

### Maximum Working Temperature:

60°C.

### Accuracy:

±2% Typical.

### Repeatability:

±1%.

### Connections:

1/4" and 3/4" tapered threads.

### Calibration (Air):

1 bar absolute at 20°C.

## INSTALLATION DETAILS

### Simple to fit, Easy to use

The LoFlow meter has been designed for those industries where the need exists for a low cost solution to small measurements of flow with an accurate reading. LoFlow uses the well tried and tested principle of variable area flow measurement utilising the movement of a ball or float inside a calibrated tapered tube.

## TYPICAL APPLICATIONS

Monitoring inert gases for the welding industry  
Pollution Monitoring Equipment  
Pharmaceutical Industry  
Filtration Systems

Hospital Equipment  
For Water Applications  
Water Treatment  
Photography and X-ray Equipment  
Swimming Pools

## INSTALLATION DETAILS

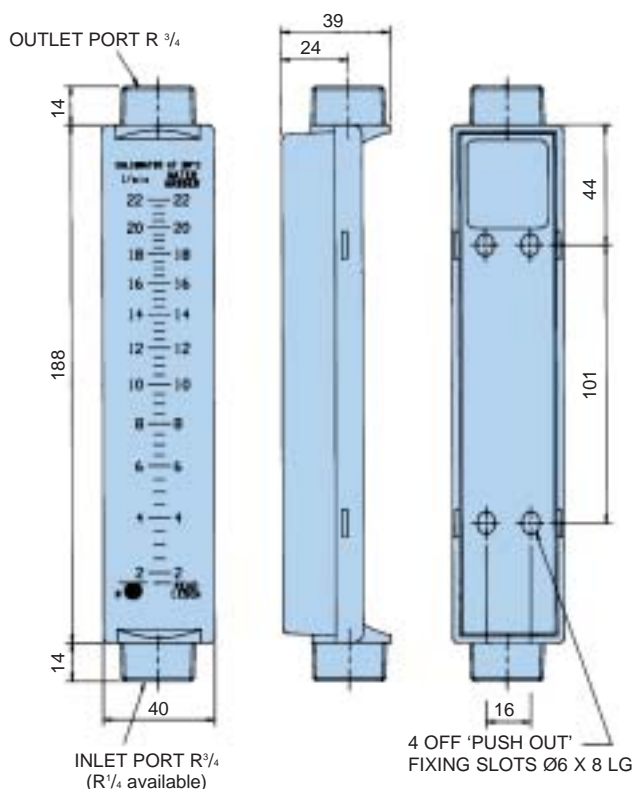

## ORDERING INFORMATION

### Oil and Water

Part Number	Media	Inlet Port (BSPT Male)	Flow Range (l/min)	Float Material
LF.1002	OIL	1/4"	0.010-0.20	S. Steel
LF.1009		3/4"	0.05-0.9	Acetal
LF.1090		3/4"	0.5-9.0	S. Steel
LF.2005	WATER	1/4"	0.06-0.55	S. Steel
LF.2020		3/4"	1.5-10.0	Acetal
LF.2100		3/4"	0.2-2.0	S. Steel
LF.2220		3/4"	2.0-22.0	S. Steel

### Air

Part Number	Inlet Port (BSPT Male)	Flow Range	Float Material
LF.3050E	3/4"	10.50.0 l/min	Acetal
LF.3135E	3/4"	20-135.0 l/min	Acetal
LF.3330E	3/4"	1.5-5.5 l/sec	S. Steel
LF.3720E	3/4"	1-12.0 l/sec	S. Steel

Note: We reserve the right to change flow ranges from those stated.

# Flowmeters & Monitors

Easiflow – Meters and Flowswitches



- Oil or water calibrated.
- Works in any plane.
- Pressures up to 10 bar.
- Flows from 1 to 150 l/min.
- Accuracy  $\pm 5\%$  FSD.
- Repeatability  $\pm 1\%$  FSD.
- Switches – fully adjustable flow rate signalling.
- Plant and equipment protection.
- Colour coded by application.
- AC/DC options available.



## EASIFLOW METERS SPECIFICATION

### Construction:

Cone	Acetal
Viewing Glass	Borosilicate Glass
Calibrated Spring	Stainless Steel
Seal	Nitrile
Body	Glass filled nylon

### Maximum Working Pressure:

10 bar

### Temperature Range:

+5°C to +80°C.

### Flow Rate:

1 to 150 l/min

### Viscosity Range:

10 to 200 centistokes (Oil)

### Accuracy:

$\pm 5\%$  FSD

### Repeatability:

$\pm 1\%$  FSD

### Connections:

1" BSP Parallel Threads

### Weight:

0.4kg

## FLOWSWITCH SPECIFICATIONS

The Easiflow switch is a flow measuring device incorporating an AC or DC switch suitable for controlling valves or pump motors or for activating alarm signals.

### General Flowmeter

#### Specification:

See material details opposite

#### DC Option:

No minimum voltage

#### Switch Type

#### Specifications:

Magnetically operated reed switch

### Electrical Details:

Please specify from the following options

110VAC – 3 Amps @	CE
110VAC max	
240VAC – 1.5 Amps @	
240VAC max	
48VDC – 0.5 Amps @	
48VDC max	

## INSTALLATION DETAILS

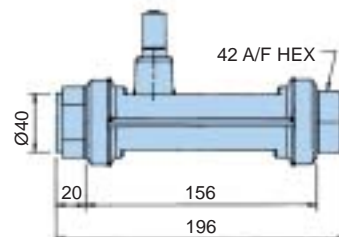
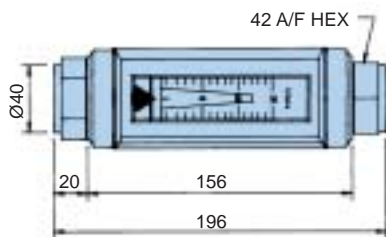

## ORDERING INFORMATION

### Oil Calibration

Part Number	Description	Flow Range
EFL.0151	OIL	1-15 l/min
EFL.0301		2-30 l/min
EFL.0501		4-50 l/min
EFL.1001		5-100 l/min
EFL.1501		10-150 l/min

### Water Calibration

Part Number	Description	Flow Range
EFW.0152	WATER	1-15 l/min
EFW.0302		2-30 l/min
EFW.0502		4-50 l/min
EFW.1002		5-100 l/min
EFW.1502		10-150 l/min

### Oil Calibration

Part Number		Falling Flow	Flow Range
AC Option*	DC Option	Switching Range	
ESL.0151	ESL.0121	5-15 l/min	1-15 l/min
ESL.0301	ESL.0321	5-30 l/min	2-30 l/min
ESL.0501	ESL.0521	10-50 l/min	4-50 l/min
ESL.1001	ESL.1021	20-100 l/min	5-100 l/min
ESL.1501	ESL.1521	30-150 l/min	10-150 l/min

### Water Calibration

Part Number		Falling Flow	Flow Range
AC Option*	DC Option	Switching Range	
ESW.0152	ESW.0122	5-15 l/min	1-15 l/min
ESW.0302	ESW.0322	5-30 l/min	2-30 l/min
ESW.0502	ESW.0522	10-50 l/min	4-50 l/min
ESW.1002	ESW.1022	20-100 l/min	5-100 l/min
ESW.1502	ESW.1522	30-150 l/min	10-150 l/min

\*Specify 110V AC or 240V AC

# Flowmeters & Monitors

Dataflow – Inline Flow Indication and Precision Monitoring



**Dataflow Indicator**



**Dataflow Monitor**

- **Indicator** gives flow visibility.
- Works in any plane.
- Accepts reverse flow.
- Indicates flow from 2 to 150 l/min.
- Pressures up to 10 bar.

- Accuracy  $\pm 5\%$  FSD typical when used in conjunction with DFI.900.
- One **monitor** can be used with many sensors.
- Imperial or metric readout.

## FLOW INDICATOR SPECIFICATION

### Construction:

Borosilicate glasstube.  
Nitrile seals.

Body –  
Glass filled nylon.

Rotor and locator –  
Acetal.

Washers and shaft –  
Stainless Steel.

Rotor tips –  
Stainless Steel.

### Maximum Working Pressure:

10 bar Oil/Water.

### Minimum flow indication:

2 l/min (Max. 150 l/min).

Accepts reverse flow.

### Temp Range:

+5°C to +80°C Oil.

+5°C to +60°C Water.

### Accuracy:

$\pm 2\%$  FSD typical.

### Repeatability:

$\pm 1$  l/min.

### Connections:

1" BSP Parallel threads.  
NPT available on request.

### Weight:

0.4 Kg.

Note: Dataflow is designed for use with liquids only.

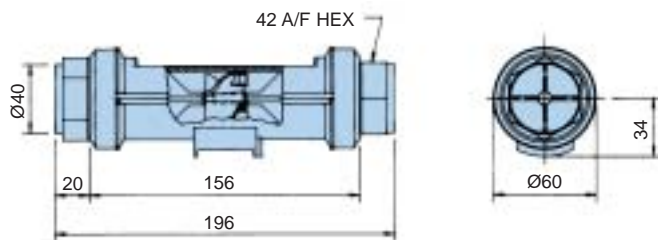

SUPPLIED WITH  
2 BONDED SEALS  
FOR INSTALLATION

## PORTABLE MONITOR SPECIFICATION

### Construction:

ABS. Dust proof electronics.

### Display:

Custom LCD – 4 digits. 5 user prompts.

### Key Pad:

Embossed keys with tactile feed back tested to 3 million operations.

2 function keys – Oil and water.

2 imperial/metric selection keys.

On/Off and hold key to capture reading.

### Displayed Units:

Oil/Water l/min/US GPM

**Battery:**   
1PP3 9V.

### Temp Range:

0°C to +50°C.

### Sensor Head Connection:

2 metres curled cable.

### Weight:

0.5 Kg.

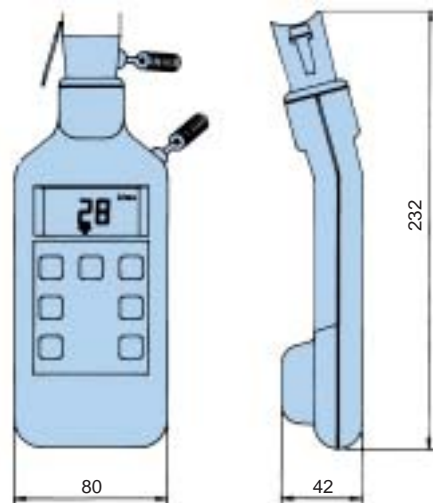

## ORDERING INFORMATION

### Indicator

Part Number	Description
<b>DFI.900</b>	Dataflow Indicator

### Monitor

Part Number	Description
<b>DFM.950</b>	Dataflow Monitor

# Flowmeters & Monitors

## Dataflow – 4 to 20mA and Pulse Output Flow Transmitters



- 4 to 20mA output.
- Pulse output available for totalising/batching.
- Works in any plane.
- Accepts reverse flow.
- Maximum flow 150 l/min.
- Negligible pressure drop.
- Pressures up to 10 bar.
- Low cost. Simple to install.
- For use with most liquids.
- Factory calibrated. Accuracy  $\pm 2\%$ .
- DIN plug connection.

### SPECIFICATION

#### Construction:

Borosilicate glasstube.  
Nitrile seals.

Body –  
Glass filled nylon.

Rotor and locator –  
Acetal.

Washers and shaft –  
Stainless Steel.

Rotor tips –  
Stainless Steel.

**Max. Working Pressure:**  
10 bar Oil/Water.

**Min. flow indication:**  
2 l/min (Max. 150 l/min).  
Accepts reverse flow.

**Accuracy:**  
 $\pm 2\%$  FSD.

**Temp Range:**  
 $+5^{\circ}\text{C}$  to  $+80^{\circ}\text{C}$  Oil.  
 $+5^{\circ}\text{C}$  to  $+60^{\circ}\text{C}$  Water.

**Connections:**  
1" BSP Parallel threads.  
NPT available on request.

**Weight:**  
0.7 Kg.

**Calibration 4 to 20mA:**  
4 to 20mA = 0 to 100 l/min  
on water.

4mA = 0 l/min,  
20mA = 100 l/min.

**Calibration Pulse Output:**  
'K' factors.  
Oil = 51.14 pulses  
per litre.  
Water = 44.25 pulses  
per litre.

**Electrical Details  
4 to 20mA:**

Supply = 24VDC .  
Output = 4 to 20mA.

**Pulse Output:**  
Supply = 24VDC  
– pulse output.  
(open collector transistor).



### INSTALLATION DETAILS

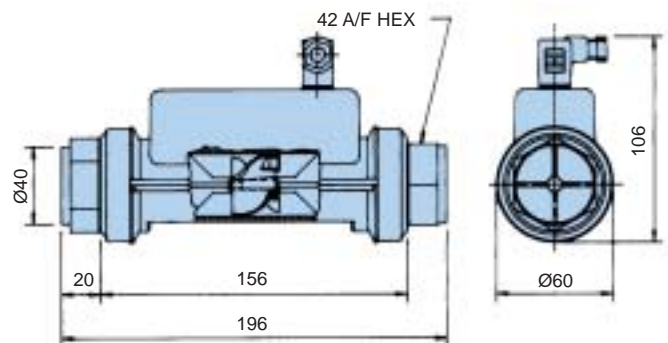

### ORDERING INFORMATION

Part Number	Description
DFT.990	Dataflow 4-20mA transmitter
DFT.980	Dataflow 'Pulse' output transmitter
DFT.991*	Dataflow digital panel display

### DIGITAL DISPLAY SPECIFICATION

**Instrument Range:**  
20mA – 100.0.

**Sensor Type/Input:**  
4 to 20mA (loop).

**Accuracy:**  
0.3% of reading.  
( $15^{\circ}\text{C}$  to  $25^{\circ}\text{C}$  ambient)  
 $\pm 1$  digit.

**Ambient Op.Range:**  
 $0^{\circ}\text{C}$  to  $+50^{\circ}\text{C}$  RH 80% max.

**Display:**  
3½ digit 12.7mm liquid  
crystal.

**Power Supply:**  
Self-powered from current  
loop.



Dataflow transmitter can be connected to an LCD readout. (DFT.991)

### 4 TO 20MA ON-SITE CALIBRATION

Set your system at zero flow. Connect a multimeter across terminals 1 (+20mA) and 2 (0mA) (Dia. 2). Set the zero to read 4mA on your multimeter (Dia. 1). Set your system to full flow and set the span to read 20mA on your multimeter. (Dia. 1)

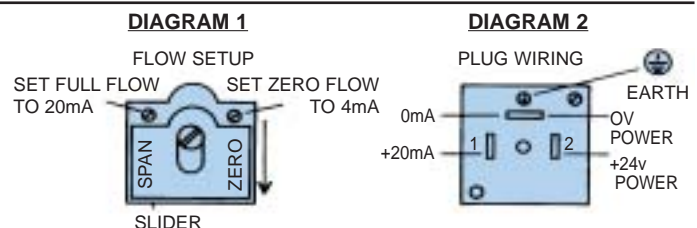

# Flowmeters & Monitors

## Dataflow Compact – Inline Flow Transmitter



- Pulse output signal for flows up to 25 l/min.
- Lightweight and robust.
- Operates in any plane. Simple to install.
- Low cost flow measurement.
- Negligible pressure drop.
- Accepts reverse flow.
- $\frac{3}{8}$  BSP connection.

## SPECIFICATION

### Construction:

Body Grilamid – TR55.  
Rotor 18% PTFE Filled Nylon.  
Shaft Stainless Steel.  
Shaft Retainers Grilamid TR55.

### Operation:

Infra-red.

### Maximum Working Pressure:

20 Bar.

### Pressure Drop:

Max 0.1 Bar at 15 l/min.

### Maximum Flow Range:

1 to 25 l/min.  
(Accepts Reverse Flow).

### Calibration:

'K' Factor 752 Pulses per Litre, typical.  
Subject to application.

### Accuracy:

±2% typical.



### Repeatability:

±1%.

### Temperature Range:

+5°C to +70°C.

### Overall Dimensions:

52mm x 29mm x 27mm.

### Weight:

16 grams.

### Connections:

$\frac{3}{8}$  BSP

### Cable Length:

300mm.

### Power Supply:

5 VDC.

## Dataflow Compact – The Low Cost Transmitter

The Dataflow Compact Transmitter was designed to offer OEM's and end users alike a means of monitoring low flows on liquids\* with an electronic output signal – but at LOW COST. Fluid passes through the one piece sensor body impacting on the twin vaned turbine rotor, causing it to rotate at a speed proportional to the flow rate. Two opposing photo-transistors are mounted either side of the rotor and externally of the clear sensor body, these generate a continuous signal.

As the rotor spins each blade obscures the infra red signal. This is then converted into an industry standard pulse output signal – compatible with inexpensive display units for flow rate, totalising, batch control etc and large, central control systems. The lightweight Grilamid body with its virtually unrestricted flow path, offers negligible pressure drop for flows up to 25 l/min and withstanding pressures up to 20 bar.

\*Note: Consult Parker Filtration on liquid suitability.

## Flow Rate • Totalising • Batch Control and applications in many industries

Dataflow Compact Transmitters are small and very robust having been developed and tested extensively in industry applications where space is the restriction, Dataflow Compact with its Grilamid body and BSP connections can be installed almost anywhere and once installed will give accurate and reliable output signalling.

## INSTALLATION DETAILS

Red Wire +5V supply  
Green Wire Output signal  
Blue Wire 0V supply

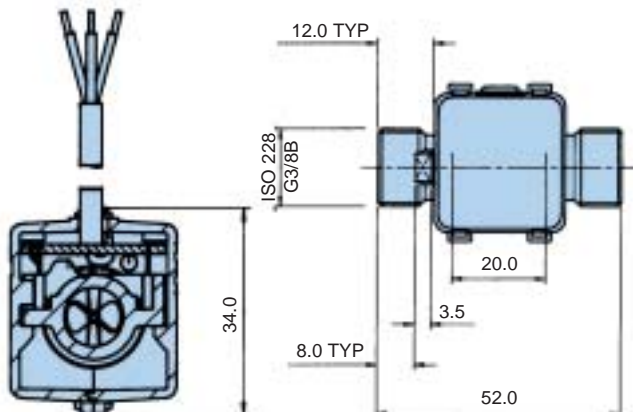

## ORDERING INFORMATION

Part Number	Description
DFC.9000.100	Dataflow Compact Transmitter

# Flowmeters & Monitors

Flowline – Oil and Water Calibrated Flowmeters (Brass and Aluminium)



- Works in any plane.
- Pressure up to 350 bar (5000 psi).
- Flows up to 1100 l/min.
- Accuracy  $\pm 5\%$  FSD.
- Repeatability  $\pm 1\%$  FSD.
- Direct reading.
- Relatively insensitive to viscosity changes.
- Oil or water calibrated.

## SPECIFICATION

### Construction:

Brass body to BS 2874 CZ114.  
3" – aluminium body to  
BS 1472.  
HE 30 TF.

### Maximum Working Pressure:

Brass – up to 350 bar.  
3" aluminium – up to 55 bar.

### Temperature Range:

Brass –20°C to +90°C.  
Aluminium –20°C to +90°C.

### Calibration:

Oil Specific gravity  
0.856 at 20°C.

Water Specific gravity  
1.0 at 20°C.

### Viscosity Range:

10 to 200 cSt (oil).

### Accuracy:

$\pm 5\%$  FSD.

### Repeatability:

$\pm 1\%$  FSD.

### Min. Scale Reading:

10% FSD.

### Connections:

BSP parallel threads.

### Wetted/Non-Wetted Parts:

Consult Parker for information.

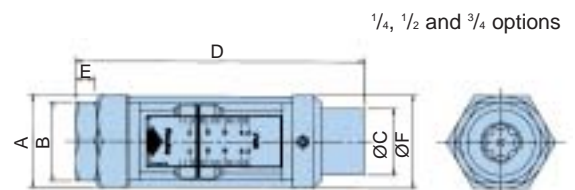

## ORDERING INFORMATION – OIL

Part Number (Body Material)	Thread Size (BSP)	Flow Range (l/min)	Maximum Working Pressure (bar)	Dimensions (mm)						Weight (Kg)
				A A/F HEX	B A/F HEX	C	D	E	F	
FM.26-122-112	1/4	0.2-2	350	32	29	19	123	7	32	0.4
FM.26-122-212	1/4	0.5-4.5	350	32	29	19	123	7	32	0.4
FM.26-122-312	1/4	1-9	350	32	29	19	123	7	32	0.4
FM.26-222-112	1/2	2-20	350	41	38	32	165.5	12.5	46	0.9
FM.26-222-212	1/2	5-46	350	41	38	32	165.5	12.5	46	0.9
FM.26-322-112	3/4	5-55	350	58	46	43	190	15	58	1.75
FM.26-322-212	3/4	10-110	350	58	46	43	190	15	58	1.75
FM.26-422-112	1 1/4	20-180	350	For installation details for 1 1/4", see next page						8.00
FM.26-422-212	1 1/4	30-270	350							8.00
FM.26-422-312	1 1/4	40-360	350							8.00
Aluminium										
S.26-612-112	3	50-750	55	133	411	–	–	–	–	7.9
S.26-612-212	3	100-1100	55	133	411	–	–	–	–	7.9

## ORDERING INFORMATION – WATER

Part Number (Body Material)	Thread Size (BSP)	Flow Range (l/min)	Maximum Working Pressure (bar)	Dimensions (mm)						Weight (Kg)
				A A/F HEX	B A/F HEX	C	D	E	F	
FM.26-122-122	1/4	0.2-2	350	32	29	19	123	7	32	0.4
FM.26-122-222	1/4	0.5-4.5	350	32	29	19	123	7	32	0.4
FM.26-122-322	1/4	1-9	350	32	29	19	123	7	32	0.4
FM.26-222-122	1/2	2-20	350	41	38	32	165.5	12.5	46	0.9
FM.26-222-222	1/2	5-46	350	41	38	32	165.5	12.5	46	0.9
FM.26-322-122	3/4	5-55	350	58	46	43	190	15	58	1.75
FM.26-322-222	3/4	10-110	350	58	46	43	190	15	58	1.75
FM.26-422-122	1 1/4	20-180	350	For installation details for 1 1/4", see next page						8.00
FM.26-422-222	1 1/4	30-270	350							8.00
FM.26-422-322	1 1/4	40-360	350							8.00
Aluminium										
S.26-612-122	3	50-650	55	133	411	–	–	–	–	7.9
S.26-612-222	3	100-1000	55	133	411	–	–	–	–	7.9

# Flowmeters & Monitors

## Flowline – Oil and Water Calibrated Flowmeters (Stainless Steel)



- For flow measurement of corrosive or chemical media.
- Manufactured in Stainless Steel 316.
- Works in any plane.
- Pressure up to 350 bar (5000 psi).
- Flows up to 360 l/min.
- Accuracy  $\pm 5\%$  FSD.
- Repeatability  $\pm 1\%$  FSD.
- Direct reading.

### DENSITY CORRECTION FACTORS (OIL)

Actual Fluid Flow rate = meter reading  $\times$  f

$$f = \sqrt{\frac{0.856 \text{ (or 1.0 for water)}}{\text{Fluid Density}}}$$

1/4" option

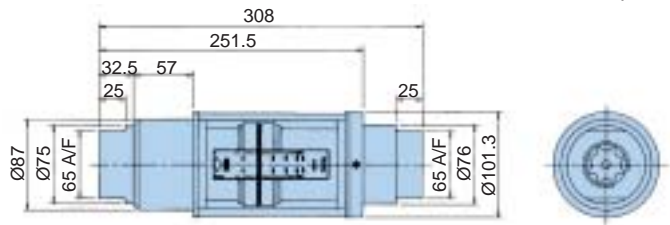

## TECHNICAL SPECIFICATIONS

### Construction:

Stainless steel to BS 970 316S.

### Viscosity range:

10 to 200 cSt (oil).

### Maximum working pressure:

Up to 350 bar.

### Accuracy:

$\pm 5\%$  FSD.

### Temperature range:

-20°C to +105°C.

### Repeatability:

$\pm 1\%$  FSD.

### Calibration:

Oil – Specific gravity 0.856 at 20°C.

### Min. Scale Reading:

10% FSD.

Water – Specific gravity 1.0 at 20°C.

### Connections:

BSP parallel threads.

### Wetted parts:

Body, Thread, Adaptor,

Piston, etc: Cone Locknut:

Stainless Steel.

Flow Cone:

BS 970 316S 16.

Magnet encapsulation:

Stainless Steel BS970/1 :1991.  
:316S31.

Spring:

Stainless steel to BS 2056  
EN 58J.

Seal:

Viton.

### Non-Wetted parts:

Consult Parker for  
information.

## ORDERING INFORMATION – OIL

Part Number (Body Material) Stainless Steel	Thread Size (BSP)	Flow Range (l/min)	Maximum Working Pressure (bar)	Dimensions (mm) see previous page						Weight (Kg)
				A	B	C	D	E	F	
FM.26-132-112	1/4	0.2-2	350	32	29	19	123	7	32	0.4
FM.26-132-212	1/4	0.5-4.5	350	32	29	19	123	7	32	0.4
FM.26-132-312	1/4	1-9	350	32	29	19	123	7	32	0.4
FM.26-232-112	1/2	2-20	350	41	38	32	165.5	12.5	46	0.9
FM.26-232-212	1/2	5-46	350	41	38	32	165.5	12.5	46	0.9
FM.26-332-112	3/4	5-55	350	58	46	43	190	15	58	1.75
FM.26-332-212	3/4	10-110	350	58	46	43	190	15	58	1.75
FM.26-432-112	1 1/4	20-180	350	See installation details for 1 1/4" above						8.00
FM.26-432-212	1 1/4	30-270	350							8.00
FM.26-432-312	1 1/4	40-360	350							8.00

## ORDERING INFORMATION – WATER

Part Number (Body Material) Stainless Steel	Thread Size (BSP)	Flow Range (l/min)	Maximum Working Pressure (bar)	Dimensions (mm) see previous page						Weight (Kg)
				A	B	C	D	E	F	
FM.26-132-122	1/4	0.2-2	350	32	29	19	123	7	32	0.4
FM.26-132-222	1/4	0.5-4.5	350	32	29	19	123	7	32	0.4
FM.26-132-322	1/4	1-9	350	32	29	19	123	7	32	0.4
FM.26-232-122	1/2	2-20	350	41	38	32	165.5	12.5	46	0.9
FM.26-232-222	1/2	5-46	350	41	38	32	165.5	12.5	46	0.9
FM.26-332-122	3/4	5-55	350	58	46	43	190	15	58	1.75
FM.26-332-222	3/4	10-110	350	58	46	43	190	15	58	1.75
FM.26-432-122	1 1/4	20-180	350	See installation details for 1 1/4" above						8.00
FM.26-432-222	1 1/4	30-270	350							8.00
FM.26-432-332	1 1/4	40-360	350							8.00





- Strap on type. One or two switches.
- ‘Boxed’ two-switch type.
- Intrinsically safe versions.  
Brass for oil and water.
- Maximum/minimum switching models.
- Maximum working pressure 350 bar.
- Flows from 0.2 to 360 l/min.
- Stainless Steel – suitable for corrosive media.
- Stainless Steel to BS970 316S16.

### ORDERING INFORMATION

To order the required switching unit, simply add the appropriate prefix before the part numbers shown below.

For full specifications and installation details, consult Parker for information.



#### Oil (Brass)

‘Strap-on’ Prefix		‘Boxed Prefix’	Intrinsically Safe Prefix		Part Number	Thread Size (BSP)	Flow Range (l/min)	Max. Working Pressure	
1 Switch	2 Switches	2 Switches	High Switch	Low Switch				(bar)	(PSI)
SO.641-	SO.643	–	–	–	<b>122-112</b>	1/4	0.2-2	350	5000
SO.641-	SO.643	–	–	–	<b>122-212</b>	1/4	0.5-4.5	350	5000
SO.641-	SO.643	–	–	–	<b>122-312</b>	1/4	1-9	350	5000
–	–	FS.643-	FS.67A-	FS.67B-	<b>222-112</b>	1/2	2-20	350	5000
–	–	FS.643-	FS.67A-	FS.67B-	<b>222-212</b>	1/2	5-46	350	5000
–	–	FS.643-	FS.67A-	FS.67B-	<b>322-112</b>	3/4	5-55	350	5000
–	–	FS.643-	FS.67A-	FS.67B-	<b>322-212</b>	3/4	10-110	350	5000
SO.641-	SO.643	–	–	–	<b>422-112</b>	1 1/4	20-180	350	5000
SO.641-	SO.643	–	–	–	<b>422-212</b>	1 1/4	30-270	350	5000
SO.641-	SO.643	–	–	–	<b>422-312</b>	1 1/4	40-360	350	5000

#### Water (Brass)

‘Strap-on’ Prefix		‘Boxed Prefix’	Intrinsically Safe Prefix		Part Number	Thread Size (BSP)	Flow Range (l/min)	Max. Working Pressure	
1 Switch	2 Switches	2 Switches	High Switch	Low Switch				(bar)	(PSI)
SO.641-	SO.643	–	–	–	<b>122-122</b>	1/4	0.2-2	350	5000
SO.641-	SO.643	–	–	–	<b>122-222</b>	1/4	0.5-4.5	350	5000
SO.641-	SO.643	–	–	–	<b>122-322</b>	1/4	1-9	350	5000
–	–	FS.643-	FS.67A-	FS.67B-	<b>222-122</b>	1/2	2-20	350	5000
–	–	FS.643-	FS.67A-	FS.67B-	<b>222-222</b>	1/2	5-46	350	5000
–	–	FS.643-	FS.67A-	FS.67B-	<b>322-122</b>	3/4	5-55	350	5000
–	–	FS.643-	FS.67A-	FS.67B-	<b>322-222</b>	3/4	10-110	350	5000
SO.641-	SO.643	–	–	–	<b>422-122</b>	1 1/4	20-180	350	5000
SO.641-	SO.643	–	–	–	<b>422-222</b>	1 1/4	30-270	350	5000
SO.641-	SO.643	–	–	–	<b>422-322</b>	1 1/4	40-360	350	5000

#### Oil and Water (Stainless Steel)

‘Strap-on’ Prefix		‘Boxed Prefix’	Zone 1 and 2 Prefix		Part Number		Thread Size (BSP)	Flow Range (l/min)	Max. Pressure (bar)
1 Switch	2 Switches	2 Switches	High Switch	Low Switch	Oil	Water			
SO.641-	SO.643	–	–	–	<b>132-112</b>	<b>132-122</b>	1/4	0.2-2	350
SO.641-	SO.643	–	–	–	<b>132-212</b>	<b>132-222</b>	1/4	0.5-4.5	350
SO.641-	SO.643	–	–	–	<b>132-312</b>	<b>132-322</b>	1/4	1-9	350
–	–	FS.643-	FS.67A-	FS.67B-	<b>232-112</b>	<b>232-122</b>	1/2	2-20	350
–	–	FS.643-	FS.67A-	FS.67B-	<b>232-212</b>	<b>232-222</b>	1/2	5-46	350
–	–	FS.643-	FS.67A-	FS.67B-	<b>332-112</b>	<b>332-122</b>	3/4	5-55	350
–	–	FS.643-	FS.67A-	FS.67B-	<b>332-212</b>	<b>332-222</b>	3/4	10-110	350
SO.641-	SO.643	–	–	–	<b>432-112</b>	<b>432-122</b>	1 1/4	20-180	350
SO.641-	SO.643	–	–	–	<b>432-212</b>	<b>432-222</b>	1 1/4	30-270	350
SO.641-	SO.643	–	–	–	<b>432-312</b>	<b>432-322</b>	1 1/4	40-360	350

# Flowmeters & Monitors

Flow Products – For Arduous Conditions



- 1/4", 1/2", 3/4" and 1 1/4" brass inline flowmeters for most liquids and gases.
- Safety shroud fitted to all products.
- Hydraulic test equipment for flow, pressure and temperature testing.
- Flows up to 360 l/min.
- Maximum working pressure 350 bar.
- Non-aluminium rugged construction.
- Oil or water calibrated.

## ORDERING INFORMATION

### Hydraulic Test Equipment

Part Number	Flow Range (l/min)	Flow Range (l/min)	Temp (°C)	Weight Kg (With Case)
4129	5-55	0-350	0-100	7.4
4130	10-110	0-350	0-100	7.4
4191	2-180	0-350	0-100	13.85
4188	3-270	0-350	0-100	13.85
4189	40-360	0-350	0-100	13.85

Note: For flowswitch specifications suitable for arduous conditions consult for information.

## ORDERING INFORMATION – FLOWMETERS

Part Number OIL	Part Number WATER	Thread Size (BSP)	Flow Range (l/min)	Max. Working Pressure (bar)
FM.26-141-112	FM.26-141-122	1/4	0.2-2.0	350
FM.26-141-212	FM.26-141-222	1/4	0.5-4.5	350
FM.26-141-312	FM.26-141-322	1/4	1-9	350
FM.26-241-112	FM.26-241-122	1/2	2-20	350
FM.26-241-212	FM.26-241-222	1/2	5-46	350
FM.26-341-112	FM.26-341-122	3/4	5-55	350
FM.26-341-212	FM.26-341-222	3/4	10-110	350
FM.26-441-112	FM.26-441-122	1 1/4	20-180	350
FM.26-441-212	FM.26-441-222	1 1/4	30-270	350
FM.26-441-312	FM.26-441-322	1 1/4	40-360	350

### High Temperature – Oil and Water Flowmeters



- Suitable for temperatures up to 180°C.
- Manufactured in stainless steel 316.
- Works in any plane.
- Pressure up to 350 bar.
- Flows up to 360 l/min.
- Relatively insensitive to viscosity changes, between 10 to 200 cSt (oil).

## ORDERING INFORMATION – FLOWMETERS

Part Number OIL	Part Number WATER	Thread Size (BSP)	Flow Range (l/min)	Max. Pressure (bar)	Weight (kg)
HT.26-132-112	HT.26-132-122	1/4	0.2-2.0	350	0.4
HT.26-132-212	HT.26-132-222	1/4	0.5-4.5	350	0.4
HT.26-132-312	HT.26-132-322	1/4	1-9	350	0.4
HT.26-232-112	HT.26-232-122	1/2	2-20	350	0.9
HT.26-232-212	HT.26-232-222	1/2	5-46	350	0.9
HT.26-332-112	HT.26-332-122	3/4	5-55	350	1.75
HT.26-332-212	HT.26-332-222	3/4	10-110	350	1.75
HT.26-432-112	HT.26-432-122	1 1/4	20-180	350	8.00
HT.26-432-212	HT.26-432-222	1 1/4	30-270	350	8.00
HT.26-432-312	HT.26-432-322	1 1/4	40-360	350	8.00



- Speedy diagnosis of hydraulic circuit faults.
- Flows ranging from 2 to 360 l/min.
- Measuring flow, pressure and temperature.
- Portable – No power source required.
- Hydrotrac unit for flows from 2 to 110 l/min available.

### SPECIFICATIONS

**Flow Range:**

2 to 360 l/min.

**Pressure Range:**

0 to 350 bar.

**Temperature Range:**

0°C to +100°C.

### INSTALLATION DETAILS

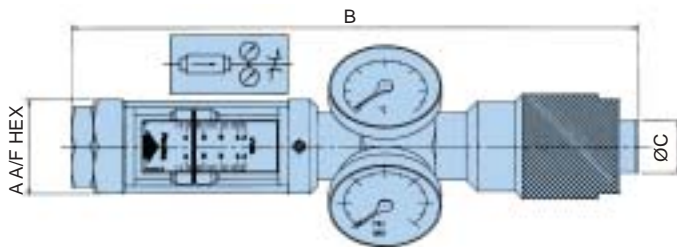

### SAFETY

An axial flow restrictor valve is fitted which can be adjusted under full load from open to fully closed, and to complete the specification, a safety blow-out disc, set to operate at 455 bar is fitted to the manifold in a position facing away from the operator when reading the gauges normally. Two spare blow-out discs are supplied which are easily replaced by removing the hexagonal plug on the gauge manifold.

### TROUBLESHOOTING TEST UNITS

Hydraulic Test Units are designed specifically for the speedy diagnosis of hydraulic circuit faults in mobile, marine and industrial systems using the normal range of mineral oils. Their rugged construction based mainly on mild steel, manganese bronze and acrylic materials makes them ideally suited for arduous use in the field.

Each unit is supplied in a convenient carrying case providing full protection and additional storage space for fittings. Because they need no power source such as batteries etc, they are always ready for instant use.

6 models are available to cover flow capacities up to 360 l/min and each incorporates a direct reading, uni-directional flow meter. The meter, which is both self cleaning and reasonably tolerant of contaminated fluids is coupled to a manifold that houses a glycerine-filled pressure gauge calibrated 0 to 350 bar and a dial-type thermometer with a 0°C to 100°C range.

For further convenience the scale on the flow meter can be rotated to ensure visibility in any situation and the installed attitude of the assembly is not critical, though whenever possible the unit should be mounted with pressure gauge vertical and gauge case relief valve uppermost. The unit is designed for flow to be in the direction of the arrow on the flowmeter scale and must not be installed with the flow reversed.

### ORDERING INFORMATION

Part Number	Flow Range (l/min)	Pressure Range (bar)	Temp (°C)	Weight Kg (With Case)	Dimensions		
					A	B	C
4120	5-55	0-350	0-100	7.40	46	350	35
4121	10-110	0-350	0-100	7.40	46	350	35
*4123	2-110	0-350	0-100	11.8	46	350	35
4168	20-180	0-350	0-100	13.85	75	496	87
4169	30-270	0-350	0-100	13.85	75	496	87
4170	40-360	0-350	0-100	13.85	75	496	87

\*Note: The 4123 'Hydrotrac' unit features 2 flowmeters – 2 to 20 l/min and 10 to 110 l/min and 2 pressure gauges.

# Flowmeters & Monitors

Flow Products – For Compressed Air Applications



## Flowline Flowswitches and Flowmeters (A)

- Calibrated for direct reading of compressed air at 7 bar.
- Works in any plane.
- Brass, stainless steel or aluminium models available in 5 sizes.
- Calibrated at 7 bar and 20°C.
- Flow ranges from 2 to 2200 SCFM.

## LoFlow Air Flowmeters (B)

- Flow measurement from 1 to 720 l/min. Max 10 bar rating.

## Compressed Air Test Equipment (C)

- 6 models available – 1/4", 3/4" and 1 1/4" BSP.
- Air flow range 2 to 600 SCFM. 1 to 41 bar max.

## TECHNICAL SPECIFICATION

Full technical specifications for the Flowmeter, Flowswitch, LoFlow and Test Equipment products are provided in the respective pages for these products.

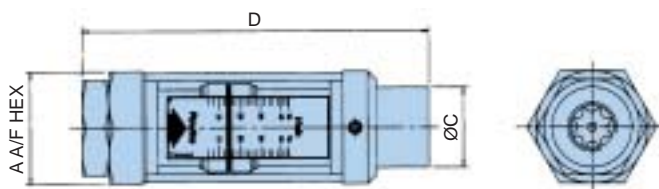

## ORDERING INFORMATION

### Flowmeters

Part Number		Thread Size (BSP)	Flow Range		Max. Working Pressure (Bar)
Brass	Stainless		(SCFM)	(l/sec)	
FM.26-123-332	FM.26-133-332	1/4	2-20	1-10	41
FM.26-223-132	FM.26-233-132	1/2	5-50	2-25	41
FM.26-223-232	FM.26-233-232	1/2	10-110	5-50	41
FM.26-323-132	FM.26-333-132	3/4	15-125	6-60	41
FM.26-323-232	FM.26-333-232	3/4	20-225	10-100	41
FM.26-423-132	FM.26-433-132	1 1/4	40-400	20-200	41
FM.26-423-232	FM.26-433-232	1 1/4	60-600	30-300	41
Aluminium					
FM.26-613-132		3	100-1400	60-600	20
FM.26-613-232		3	220-2200	100-1000	20

### Flowswitches

Part Number		Thread Size (BSP)	Flow Range		Max. Working Pressure (bar)
Brass	Stainless		(SCFM)	(l/sec)	
SO.***-123-332	SO.***-133-332	1/4	2-20	1-10	41
FS.***-223-132	FS.***-233-132	1/2	5-50	2-25	41
FS.***-223-232	FS.***-233-232	1/2	10-110	5-50	41
FS.***-323-132	FS.***-333-132	3/4	15-125	6-60	41
FS.***-323-232	FS.***-333-232	3/4	20-225	10-100	41
SO.***-423-132	SO.***-433-132	1 1/4	40-400	20-200	41
SO.***-423-232	SO.***-433-232	1 1/4	60-600	30-300	41

Note: \*\*\* refers to the prefix code. To select the correct Flowswitch prefix, see the Flowswitch section.

### LoFlow

Part Number	Inlet Ports (BSPT Male)	Flow Range (l/min)	Float Material
LF.3007E	1/4"	1-7.0 l/min	Acetal
LF.3021E	1/4"	3-19.0 l/min	S. Steel
LF.3050E	3/4"	10-50.0 l/min	Acetal
LF.3135E	3/4"	20-135.0 l/min	Acetal
LF.3330E	3/4"	1.5-5.5 l/sec	S. Steel
LF.3720E	3/4"	1-12.0 l/sec	S. Steel

Note: We reserve the right to change flow ranges from those stated.

## Compressed Air Test Equipment

Part Number	Thread Size (BSP)	Flow Range		Max. Working Pressure (bar)	Weight Kg (With Case)
		(SCFM)	(l/sec)		
4178	1/4	2-20	1-10	41	1.2
4164	3/4	5-50	2-25	41	7.4
4163	3/4	15-125	6-60	41	7.4
4192	3/4	20-225	10-100	41	7.4
4193	1 1/4	40-400	20-200	41	13.85
4194	1 1/4	60-600	30-300	41	13.85



Parker Hannifin (UK) Ltd

Filter Division Europe

Condition Monitoring Centre

Brunel Way, Thetford

Norfolk, IP24 1HP, UK

Phone: +44 (0) 1842 763299

Fax: +44 (0) 1842 756300

Email: commoninfo@parker.com

www.ucc.co.uk