



Directional Control Valves

Series VA13 and VA15

3- and 5-port valves, G1/8

Catalogue 9127003472GB-ul

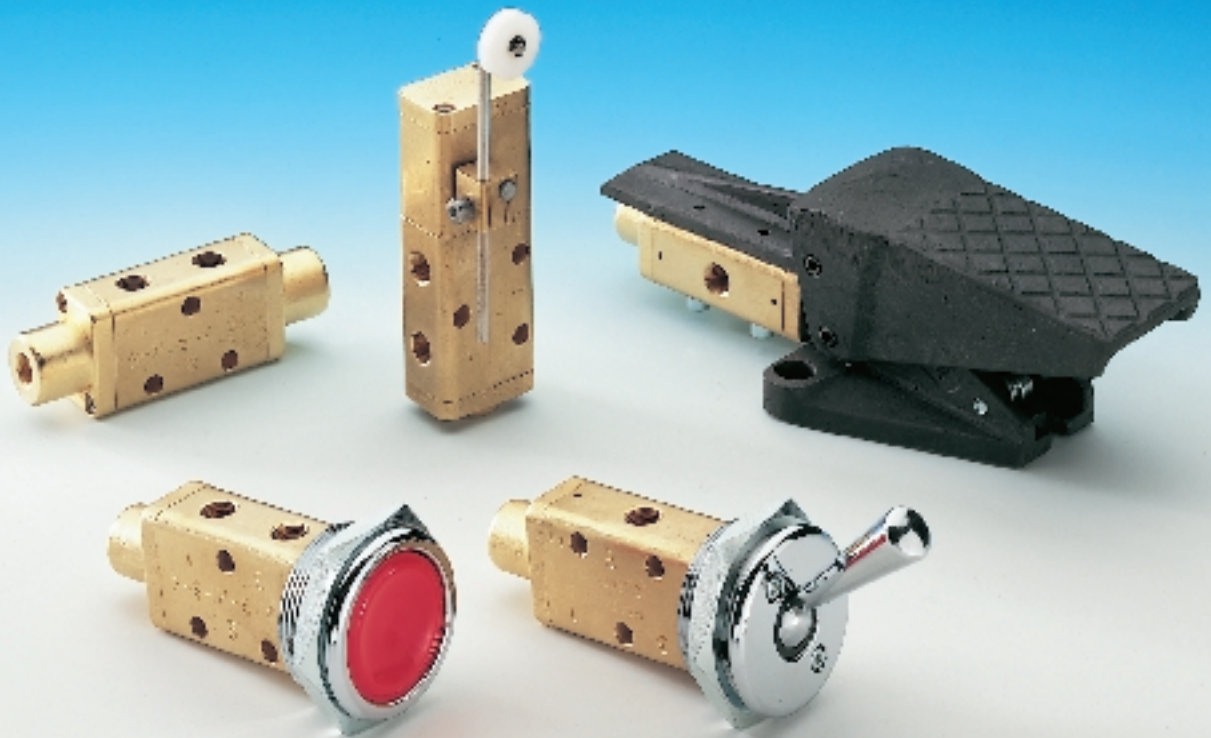
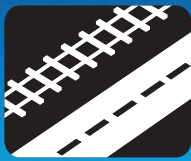

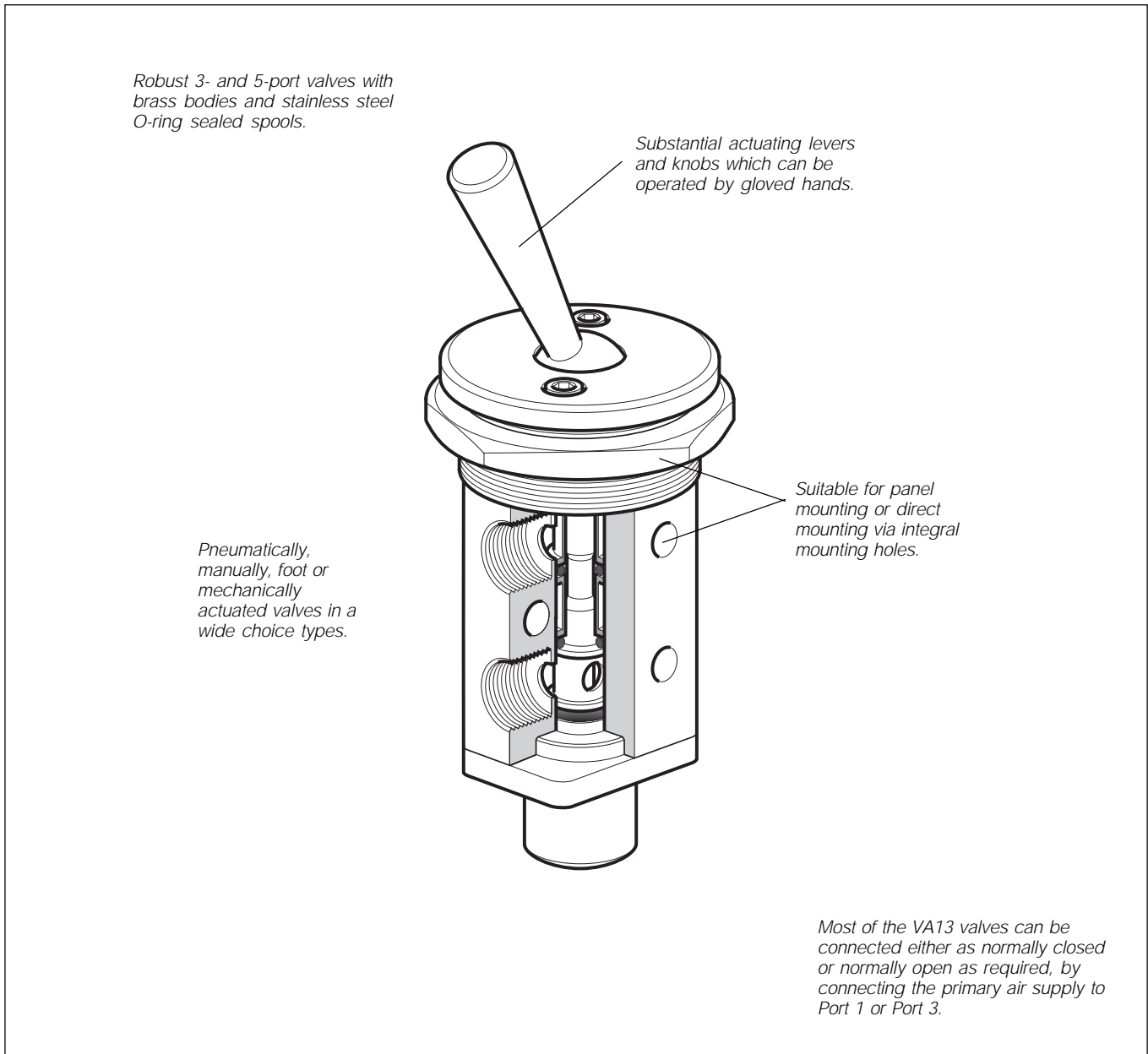

VA13 and VA15

3- and 5-port valves, size G1/8

The VA13/15 valve range consists of spool valves of extremely robust design, incorporating a wide range of manual, mechanical and pilot-operated actuators.

The robust design, coupled with good corrosion resistance, makes the valves suitable for a wide range of applications. Manually operated valves are suitable for industrial and transport applications. The stable and ergonomically designed actuators make the valves easy to operate even with heavy working gloves.

The valve bodies and caps are made of brass. Stainless steel is used in the spools and the mechanical actuating devices. Versions intended for panel mounting have chromium-plated steel actuators and panel bezels.

Ordering example

VA13-HIS4

- Valve type, VA _____
- Valve size 1 = G1/8 _____
- Number of ports, 3 or 5 _____
- Supplementary code _____
- X = 5/3 valve with exhausted centre position _____
- Type of actuation _____
- Type of return _____
- Type of installation _____
- 4 = panel mounted _____



Products specially suitable for the transport industry.

Installation

Correctly mounted valves require only a minimum of maintenance. For maximum life, follow the instructions with regard to actuation directions, actuation speeds, angles and adjustments.

Panel mounting

Mount the valves in a 40,5 mm diameter hole (thread M40 x 1,5). The panel-mounting collars have a flange on the front of the panel and a retaining nut behind the panel, for simple installation and clean and attractive appearance.

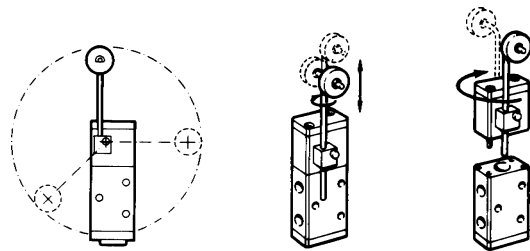

Fitting adjustable roller actuators

The rest position of the actuating arm can be arranged at any required angle on the actuator shaft (360°).

The length of the arm is adjustable, and it can also be rotated through 180°. Note, however, that the roller must always be parallel to the valve body.

The arm can also be positioned on the other side of the valve by removing the actuating mechanism, turning it through 180° and reassembling it.

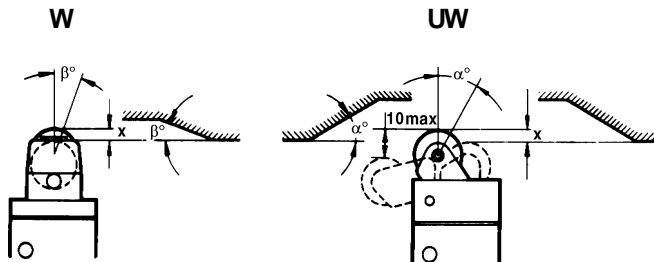

Actuation

Maximum actuation distance (X), i.e. the maximum spool stroke length, is 4 mm. Valves are fully open after 3,5 mm travel. Type UW toggle cam actuators permit a vertical motion in toggle direction of up to 10 mm.

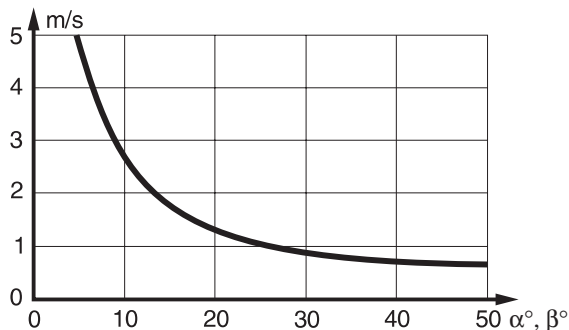

Actuation speed as a function of actuation angle

Optimum valve life will be obtained if the shape of actuation cams is matched to the method of actuation employed. The principle is that the higher the speed of the actuating motion, the smaller the incident angle. The characteristic curve shown here plots the incident angle against speed of the actuating stroke.

WG

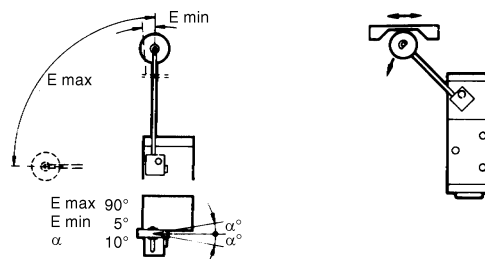

Actuation by adjustable roller

Actuation can be arranged in both directions if the arm is set as shown above. The arm needs to be moved through only 5° to make the valve change over, although a travel range of up to 90° can be accepted.

Material specifications

Valve bodys, end covers,	Brass
spring guides	Polished stainless steel
Spools	Nitrile rubber
Seals	Zinc plated steel
Screws, nuts, washers	Steel
Balls	Acetal plastic
Push-buttons, knobs	Chrome-plated steel
Levers	Phosphatized cast-iron
Pedals	Hardened stainless steel
I-plunger	Acetal plastic
Rollers	



IMPORTANT

Before servicing, make sure that the valve is depressurised. Disconnect the primary air hose to ensure that the air supply is safely interrupted before removing valves.

Data

Working temperature:	-20 °C to +70 °C
Working pressure:	max 10 bar
Flow (acc. to ISO 6358)	
C:	0,9 NI/s, bar
Qn (P1=6 bar, Δp=1 bar):	3,6 l/s
Qmax:	6,3 l/s
Cv:	0,21

Dimensions see page 10

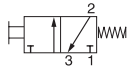
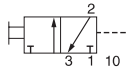
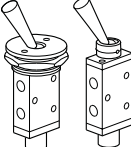
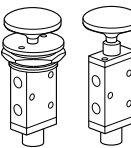
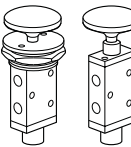
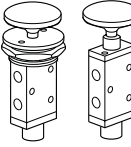
Symbol	Actuator	Return	Mounting	Changeover force at 6 bar	Weight kg	Order code
	Push-button Red	Spring	Panel mounted	32,5 N	0,37	VA13-HIS4
	Push-button Black	Spring	Panel mounted	32,5 N	0,37	VA13-HIS4A06*
	Push-button Red	Air signal	Panel mounted	6 N**	0,37	VA13-HIA4
	Hand lever Held in two positions	Hand lever	Panel mounted	8 N	0,52	VA13-HB24
			Side mounted	8 N	0,35	VA13-HB2
	Knob Red Two positions	Knob	Panel mounted	3 N	0,48	VA13-KL24
			Side mounted	3 N	0,31	VA13-KL2
	Knob Red	Spring	Panel mounted	31,5 N	0,49	VA13-KS4
			Side mounted	31,5 N	0,32	VA13-KS
	Knob Red Two positions	Knob/ Air signal	Panel mounted	6 N**	0,49	VA13-KL2A4
			Side mounted	6 N**	0,33	VA13-KL2A

* Panel holder in black anodized aluminium.

** Without signal pressure. Signal pressure min 3 bar at 6 bar supply pressure.

Accessories for VA13/15HI... series valve

Description	Weight kg	Order code
Diaphragm		
Diaphragm, black	0,01	9127 3593-31
Diaphragm, yellow	0,01	9127 3593-32
Mounting ring		
Mounting ring	0,02	9127 3593-34

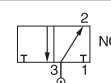
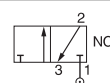





All VA13 valves (except VA13-WGR and VA13-RWG) can be connected either as normally closed 3/2 valve (NC) or normally open 3/2 valve (NO) as required, by connecting the primary air supply to Port 1 or Port 3.

Data

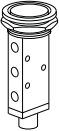
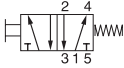
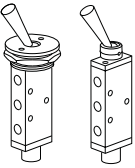
Working temperature: -20 °C to +70 °C
 Working pressure: max 10 bar
 Flow (acc. to ISO 6358)
 C: 0,9 NI/s, bar
 Qn (P1=6 bar, Δp=1 bar): 3,6 l/s
 Qmax: 6,3 l/s
 Cv: 0,21

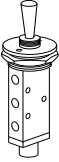
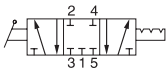
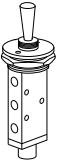
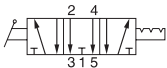
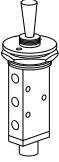
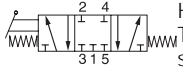
Dimensions see page 11

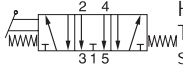
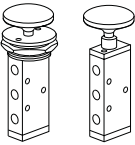
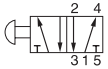
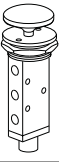
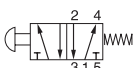
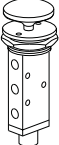
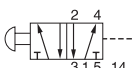
	Symbol	Actuator	Return	Mounting	Changeover force at 6 bar	Weight kg	Order code
		Push-button Red	Spring	Panel mounted	34,5 N	0,46	VA15-HIS4
		Hand lever Held in two positions	Hand lever	Panel mounted	9 N	0,63	VA15-HB24
				Side mounted	9 N	0,45	VA15-HB2
		Hand lever Held in three positions	Hand lever	Panel mounted Closed centre position	9 N	0,63	VA15-HB34
		Hand lever Held in three positions	Hand lever	Panel mounted Exhausted centre position	9 N	0,63	VA15-XHB34
		Hand lever Three positions self-centring	Hand lever	Panel mounted Closed centre position	9 N	0,63	VA15-HC4
		Hand lever Three positions self-centring	Hand lever	Panel mounted Exhausted centre position	9 N	0,63	VA15-XHC4
		Knob Red Two positions	Knob	Panel mounted	5 N	0,58	VA15-KL24
				Side mounted	5 N	0,42	VA15-KL2
		Knob Red	Spring	Panel mounted	34,5 N	0,60	VA15-KS4
		Knob Red Two positions	Knob/Air signal	Panel mounted	8 N*	0,61	VA15-KL2A4

*Without signal pressure. Signal pressure min 3 bar at 6 bar supply pressure.

Data

Working temperature:	-20 °C to +70 °C
Working pressure:	max 10 bar
Flow (acc. to ISO 6358)	
C:	0,9 NI/s, bar
Qn (P1=6 bar, Δp=1 bar):	3,6 l/s
Qmax:	6,3 l/s
Cv:	0,21

VA13

Dimensions see page 12

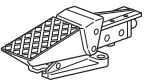
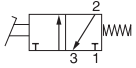
Symbol	Actuator	Return	Mounting	Changeover force at 6 bar	Weight kg	Order code
 	Pedal	Spring	Foot mounted	23,5 N	1,14	VA13-FS



All VA13 valves (except VA13-WGR and VA13-RWG) can be connected either as normally closed 3/2 valve (NC) or normally open 3/2 valve (NO) as required, by connecting the primary air supply to Port 1 or Port 3.

VA15

Dimensions see page 12

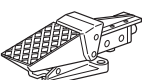
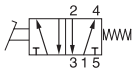
Symbol	Actuator	Return	Mounting	Changeover force at 6 bar	Weight kg	Order code
 	Pedal	Spring	Foot mounted	24,5 N	1,25	VA15-FS

Data

Working temperature:	-20 °C to +70 °C
Working pressure:	max 10 bar
Flow (acc. to ISO 6358)	
C:	0,9 NI/s, bar
Qn (P1=6 bar, Δp=1 bar):	3,6 l/s
Qmax:	6,3 l/s
Cv:	0,21



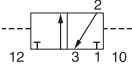
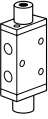
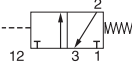
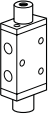
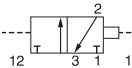

VA13

Dimensions see page 13

	Symbol	Actuator	Return	Mounting	Signal pressure min, bar at 6 bar actu./return	Weight Kg	Order code
		Air signal	Air signal	Side mounted	3/3	0,33	VA13-AA
		Air signal	Spring	Side mounted	4/-	0,32	VA13-AS
		Air signal with priority	Air signal	Side mounted	3/4	0,32	VA13-ADA

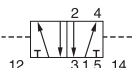
VA15

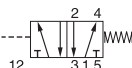

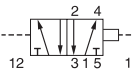

Dimensions see page 13

	Symbol	Actuator	Return	Mounting	Signal pressure min, bar at 6 bar actu./return	Weight Kg	Order code
		Air signal	Air signal	Side mounted	3/3	0,33	VA15-AA
		Air signal	Spring	Side mounted	4/-	0,32	VA15-AS
		Air signal with priority	Air signal	Side mounted	3/4	0,32	VA15-ADA

Data

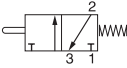
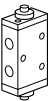
Working temperature:	-20 °C to +70 °C
Working pressure:	max 10 bar max 8 bar for WGR and RWG
Flow (acc. to ISO 6358)	
C:	0,9 NI/s, bar
Qn (P1=6 bar, Δp=1 bar):	3,6 l/s
Qmax:	6,3 l/s
Cv:	0,21

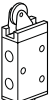
Dimensions see page 14

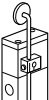
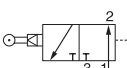
	Symbol	Actuator	Return	Mounting	Changeover force at 6 bar	Weight kg	Order code
		Plunger	Spring	Side mounted	32,5 N	0,30	VA13-IS
		Plunger Two positions	Plunger	Side mounted	3 N	0,30	VA13-II
		Plunger	Air signal	Side mounted	6 N*	0,30	VA13-IA
		Roller one way trip	Spring	Side mounted	20,5 N	0,33	VA13-UWS
		Roller	Spring	Side mounted	32,5 N	0,33	VA13-WS
		Roller on an arm	Internal air min 4 bar	Side mounted Normally closed	0,6 N min	0,41	VA13-WGR
		Roller on an arm	Internal air min 4 bar	Side mounted Normally open	0,6 N min	0,41	VA13-RWG

* Without signal pressure. Signal pressure min 3 bar at 6 bar supply pressure.

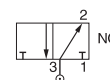
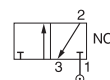







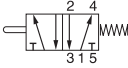

All VA13 valves (except VA13-WGR and VA13-RWG) can be connected either as normally closed 3/2 valve (NC) or normally open 3/2 valve (NO) as required, by connecting the primary air supply to Port 1 or Port 3.

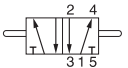
Data

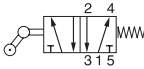
Working temperature:	-20 °C to +70 °C
Working pressure:	max 10 bar max 8 bar for WGR
Flow (acc. to ISO 6358)	
C:	0,9 NI/s, bar
Qn (P1=6 bar, Δp=1 bar):	3,6 l/s
Qmax:	6,3 l/s
Cv:	0,21

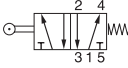
Dimensions see page 15

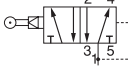
	Symbol	Actuator	Return	Mounting	Changeover force at 6 bar	Weight kg	Order code
		Plunger	Spring	Side mounted	34,5 N	0,40	VA15-IS
		Plunger Two positions	Plunger	Side mounted	5 N	0,40	VA15-II
		Roller one way trip	Spring	Side mounted	21,6 N	0,43	VA15-UWS
		Roller	Spring	Side mounted	34,5 N	0,44	VA15-WS
		Roller on an arm	Internal air min 4 bar	Side mounted	0,6 N min	0,46	VA15-WGR

Dimensions

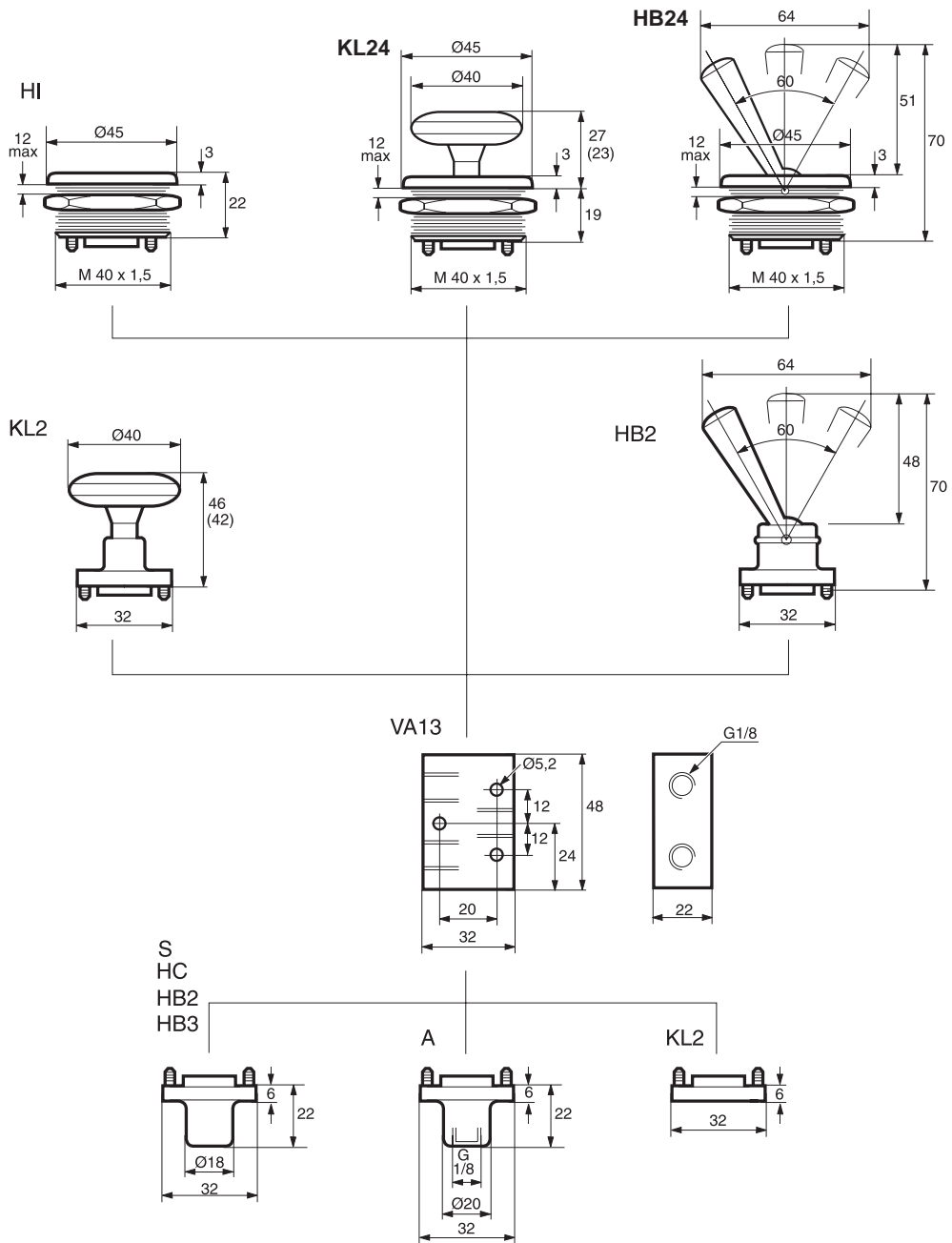

Dimensions

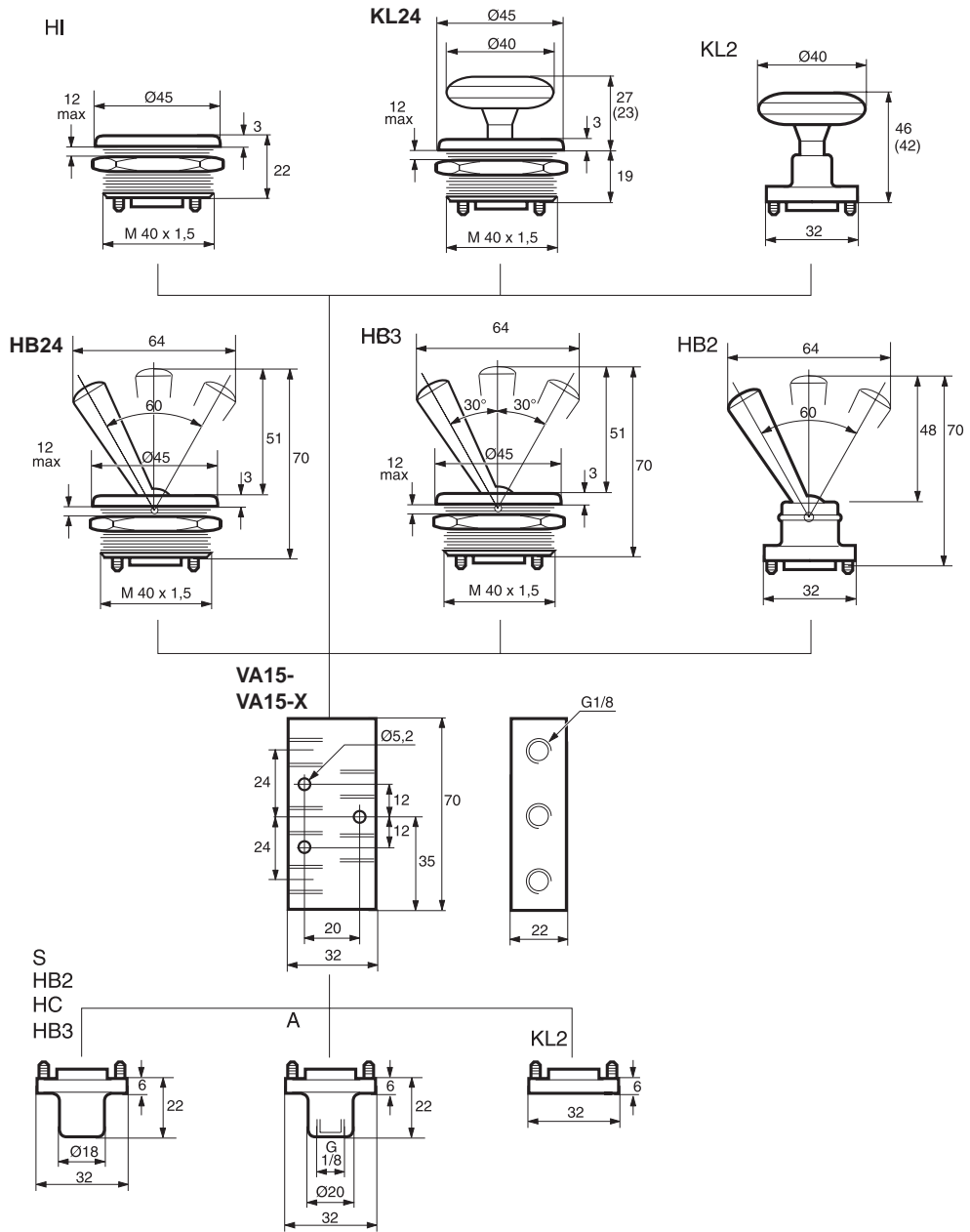

Dimensions

VA13-FS

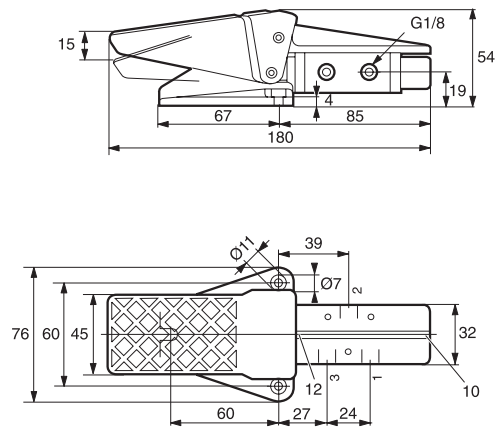

VA15-FS

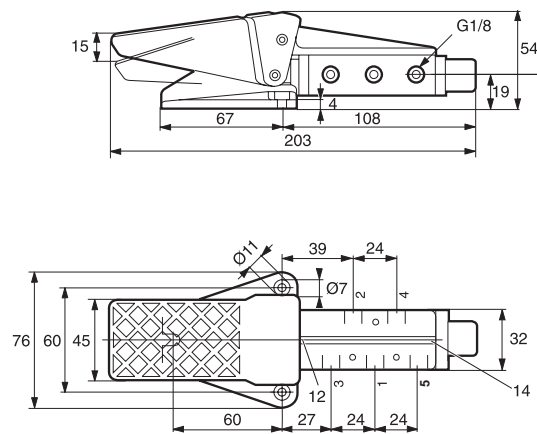

Dimensions

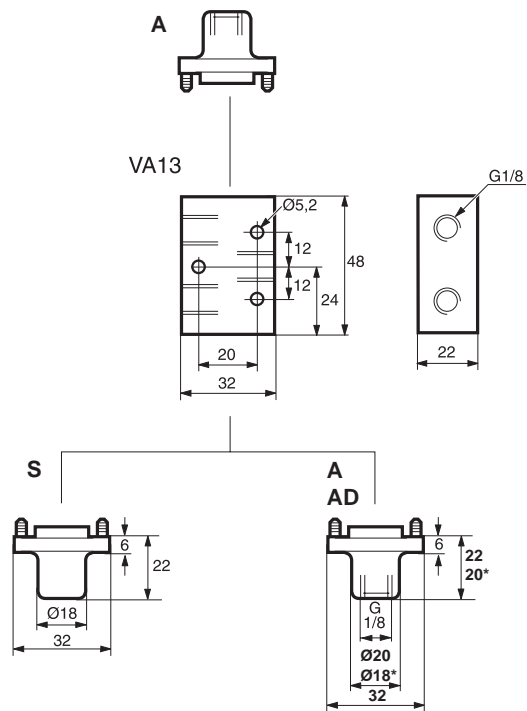

* Dimension on A-end at AD actuation

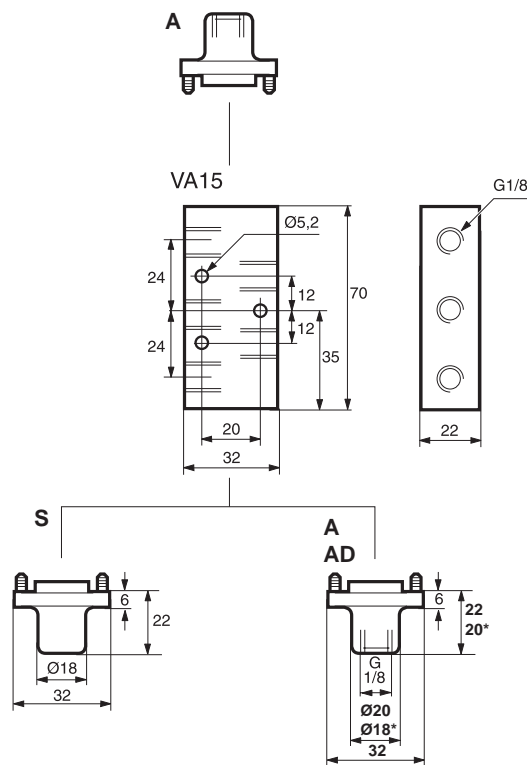

* Dimension on A-end at AD actuation

Dimensions

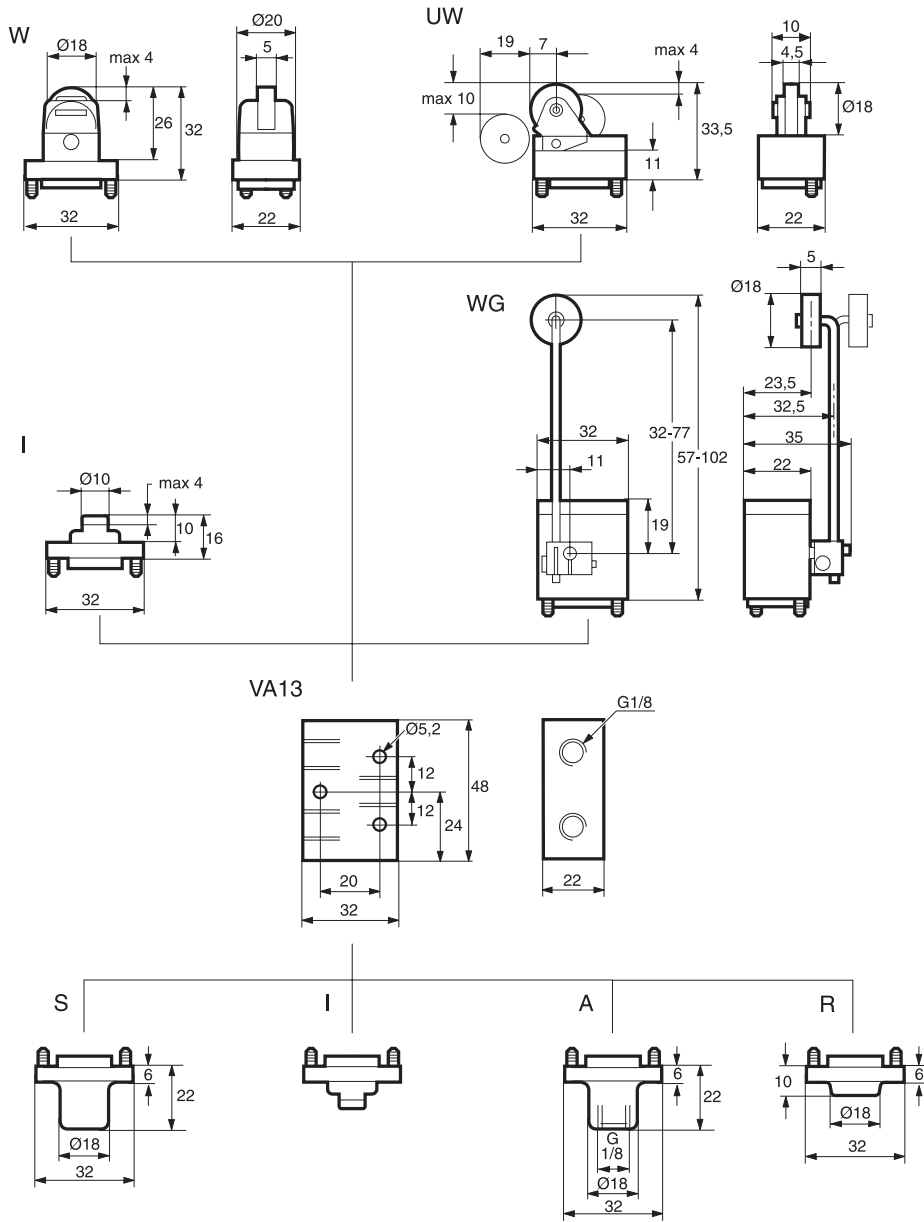

Dimensions

