



# **Moduflex Proportional Technology**

## **Proportional Regulator MPT40**

1/8" and 1/4" ported

Catalogue no. PDE2534TCUK-ab



# Moduflex proportional technology

## Man-machine interface

High visibility LED display  
Easy to read characters  
All controls on the same face

## Total flexibility

User friendly and easily accessible software  
One basic unit suits all customer requirements

## Special applications

Food version:  
Clean line design  
Suitable for washdown: IP65

## Compact & light weight

Small envelope  
Light weight (P3HP = 285 gram)

## Energy Saving

Low Watt Power Consumption  
No Unnecessary Loss of Air in Steady State



## Flexible mounting options

Stand-alone  
Foot bracket mounting  
DIN-rail mounting

# Moduflex proportional technology

## Generic Industries



The new P3HP Regulator is designed to quickly and accurately adjust and maintain a set output pressure.

The unit will operate regardless of flow, in response to an electronic control signal. The medium can be compressed air or an inert gas.

Applications for this technology are virtually unlimited; from paint spray control, paper manufacture and printing to weaving and laser cutting control; in fact anywhere that requires accurate remote pressure control.

## Automation

In the field of general automation, the need to control processes or movement via electronic signals is of paramount importance. This new unit provides the facility to incorporate pressure control into a fully integrated control system.



## Packaging and Food



The Packaging and Food industry provides another ideal area for application of the Electronic Proportional Regulator, where fine control of tension on wrapping foils and paper is required. The degree of control and the ability to manually change parameters makes this unit ideally suited to the varying requirements of this industry.

## Automotive

Applications for this innovative product in the Automotive industry can be seen in major manufacturers 'body-in-white' lines.

The control of clamping and welding forces during panel assembly is an ideal application, also accurate control in paint dipping and spraying can be achieved



### Outstanding performance

- Very fast response times
- Full flow exhaust
- Excellent linearity

# Moduflex proportional technology

---

## Why proportional technology ?

### The difference between open or closed circuit control

Standard pressure regulators, designed as part of our FRL series go a long way towards meeting our customers needs. In most cases these regulators work well in general pneumatic and automation applications. However, sometimes the application calls for more precise pressure control. The effects of time, cycling, input, back pressure or pressure and flow variation can all cause inconsistencies in pneumatic systems. Our new Proportional Regulators are designed to eliminate those inconsistencies.

#### Open Control Circuit

In a normal pressure regulated control system, the inlet pressure (p1) is converted into the output pressure (p2) by the regulator. The set pressure (set value) is usually manually set by adjusting the control knob and in normal circumstances the regulator maintains the output pressure (actual value). No facility for monitoring the output pressure is provided and there is consequently no way of checking that the set value and the actual value are the same. Also, no account is taken of external influences such as air consumption by the system, which can drastically alter the actual value.

#### Closed Loop Control Circuit

The input signal (set value) is converted into the output value (actual value) - as in control systems but this output value is continuously measured and compared with the input signal. If they are different, the regulation unit intervenes and adjusts the output value to correspond to the set value.

#### Proportional Pressure Regulators

The new P3H-P provides all the advantages of a closed circuit regulated system. When a set value is defined via the input signal (e.g. 0-10V), the pressure regulator sets the corresponding output pressure (e.g. 0-10 bar). At the same time the integrated pressure sensor measures the actual pressure at the unit's outlet (actual value). If the electronic regulation system finds that the actual value has deviated from the set value, it immediately corrects the actual value. This is a continuous process ensuring fast, accurate pressure regulation.

## Typical application in automotive body in white welding pressure control

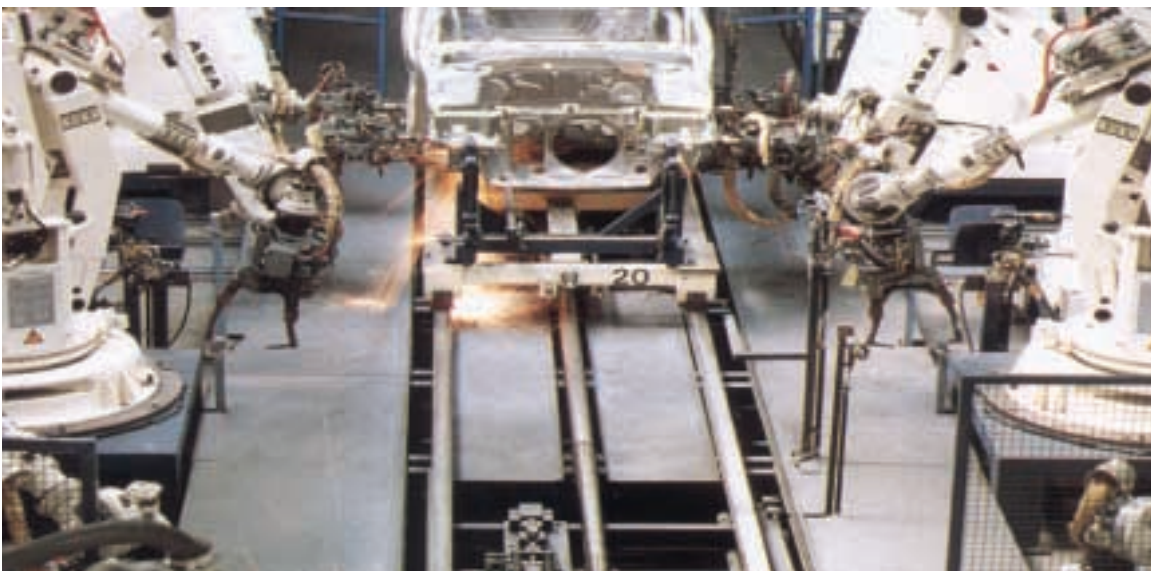

## Order Key

<b>P</b>	<b>3</b>	<b>H</b>	<b>P</b>	<b>A</b>	<b>1</b>	<b>2</b>	<b>A</b>	<b>S</b>	<b>2</b>	<b>V</b>	<b>D</b>	<b>1</b>	<b>A</b>
----------	----------	----------	----------	----------	----------	----------	----------	----------	----------	----------	----------	----------	----------

Port type	
1	G Thread (BSP) Female
9	NPT Female

Port or tube size	
1	1/8
2	1/4

Version	
A	Bottom exhaust
B	Side exhaust
F	Food version

Pressure Range	
Z	0 - 2 bar
S	0 - 7 bar
D	0 - 10 bar

Power supply	
2	24 volts

Control Signal	
A	4-20mA
V	0-10 V

Feedback	
D	Digital, PNP
A	Analogue 0-10V

Input connector	
1	M12 (4 pin)
2	M8 (4 pin)

On request

## Popular Options

Port Size	Order Code	Control Signal	Output Pressure
G1/4	<b>P3HPA12AZ2AD1A</b>	4-20mA	0 - 2 bar
G1/4	<b>P3HPA12AS2AD1A</b>	4-20mA	0 - 7 bar
G1/4	<b>P3HPA12AD2AD1A</b>	4-20mA	0 - 10 bar
G1/4	<b>P3HPA12AZ2VD1A</b>	0 - 10 V	0 - 2 bar
G1/4	<b>P3HPA12AS2VD1A</b>	0 - 10 V	0 - 7 bar
G1/4	<b>P3HPA12AD2VD1A</b>	0 - 10 V	0 - 10 bar

## Mounting Options

Order Code	Description
<b>P3HKA00MK</b>	DIN rail mounting kit
<b>P3HKA00MF</b>	Foot bracket mounting kit



DIN rail

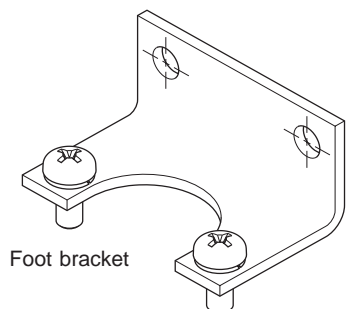

Foot bracket

For dimensional information, refer to page 15.

## Cable's

Order Code	Description
<b>P8L-MC04A2A-M12</b>	2 mtr. cable with moulded straight M12x1 connector
<b>P8L-MC04R2A-M12</b>	2 mtr. cable with moulded 90 degree M12x1 connector.

# Moduflex proportional technology

## Technical information

### Pneumatics

#### Working medium

Compressed air or inert gasses, filtered to min. 40 $\mu$ , lubricated or non-lubricated, dried or un-dried, pressure dewpoint 3-5 $^{\circ}$ C.

#### Supply pressure

Max. Operating Pressure:  
 2 bar unit: ..... 3 bar (43.5 PSI)  
 7 bar unit: ..... 10.5 bar (152 PSI)  
 10 bar unit: ..... 10.5 bar (152 PSI)  
 Min. Operating Pressure ... P2 Pressure + 0,5 bar (7.3 PSI)

#### Pressure control range

Available in three pressure ranges, 0-2 bar, 0-7 bar or 0-10 bar. Other ranges on request. Pressure range can be changed through the software at all times. (parameter 19)

#### Temperature range

0 $^{\circ}$ C up to +50 $^{\circ}$ C (32 $^{\circ}$ F up to 122 $^{\circ}$ F)

#### Weight:

P3HP = 285 gram

#### Air consumption

No consumption in stable regulated situation.

#### Display

The regulator is provided with a digital display, indicating the output pressure, either in BAR or PSI. The factory setting is as indicated on the label, can be changed through to software at all times (parameter 14).

### Electronics

#### Supply voltage

24 VDC +/- 10%

#### Power consumption

Max. 1.1W with unloaded signal outputs

#### Control signals

The electronic pressure regulator can be externally controlled through an analogue control signal of either 0-10V or 4-20mA.(parameter 4 see page 9).

#### Output signals

As soon as the output pressure is within the signal band a signal is given of 24V DC, PNP Ri = 1 kOhm  
 Outside the signal band this connection is 0V.

#### Connections

Central M12 connector 4-pole

The electrical connections are as follows:

Pin no.	Function	Colour
1	24V supply	brown
2	0-10V control signal Ri = 100 kOhm	white
3	0V (GND) supply	blue
4	24V alarm output signal	black

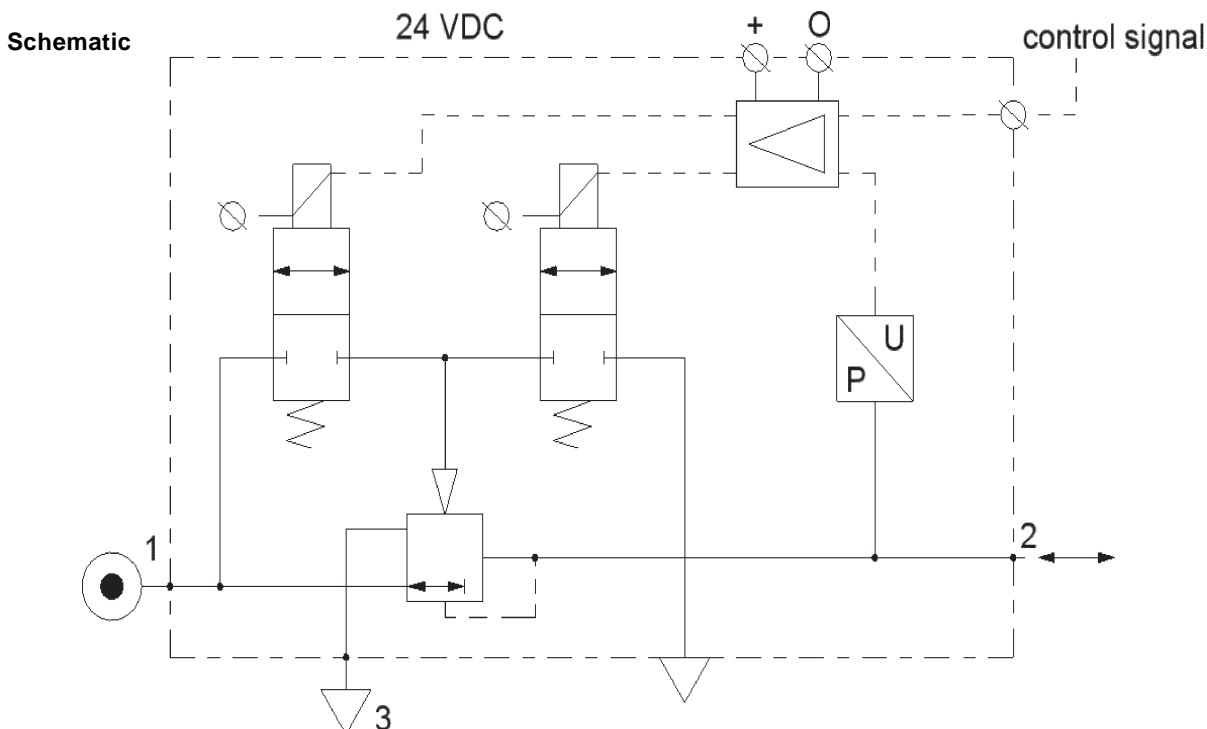

\*F.S. = Full scale = chosen max. output pressure = 100% pressure control range.



## Technical information

### Dead band

The dead band is preset at 1,3% F.S.\*  
(parameter 13, see page 12)

### Accuracy

Linearity: = < 0,3% F.S.\*

### Proportional band

The proportional band is preset at 10% F.S.\*

### Fail safe operation

After interrupting the **power supply** the present output pressure is maintained at approximately the same level.  
After switching on the power supply again the pressure can be adjusted immediately by giving a new control signal.

### Full exhaust

Complete exhaust of the regulator is defined as  $P_2 \leq 1\% \text{ F.S.}^*$

### Degree of protection

IP 65

### EU conformity

CE: standard  
EMC: according to directive 89/336/EEC  
The new pressure regulator is in accordance with:

**EN 61000-6-1:2001**  
**EN 61000-6-2:2001**  
**EN 61000-6-3:2001**  
**EN 61000-6-4:2001**

These standards ensure that this unit meets the highest level of EMC protection.

### Mounting position

Preferably vertically, with the cable gland on top.

### Materials

Parts in contact with the working media:

- Magnet Core ..... Steel
- Solenoid Valve Poppet ..... FPM
- Core Housing ..... Brass
- Solenoid Valve Housing ..... Techno Polymer
- Regulator Housing ..... Techno Polymer
- Valve ..... Polyurethane
- Seats and Auxiliary Piston ..... Delrin, Brass
- Remaining Seals ..... NBR
- Port Connections  
Standard Version ..... Brass  
Food ..... Stainless Steel

## Regulation characteristics

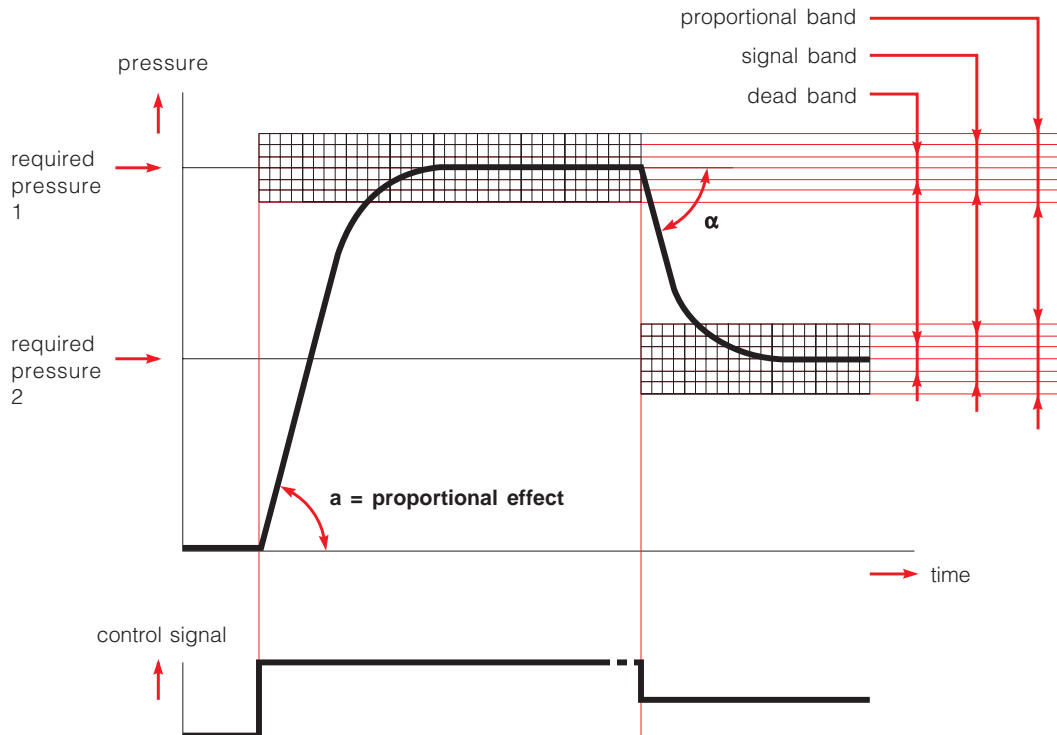

\*F.S. = Full scale = chosen max. output pressure = 100% pressure control range.

# Moduflex proportional technology

## Advanced functionality

### Pilot valve protection

When the required output pressure can not be achieved because of a lack of input pressure the unit will open fully and will display NoP. Approximately every 10 seconds the unit will retry. The output pressure will then be approximately equal to the inlet pressure. As soon as the input pressure is back on the required level, the normal control function follows.

### Safety exhaust

Should the **control signal** fall below 0,1 volts the valve will automatically dump downstream system pressure .

### Fail safe

When the **supply voltage** drops below 19VDC, the electronic control reverts to the fail safe mode. The last known output pressure is maintained at approximately the same level depending upon air consumption. The digital display indicates the last known pressure setting. When the supply voltage is reinstated to the correct level, the valve moves from the fail safe mode and the output pressure immediately follows the control signal requirement. The display indicates the actual output pressure.

### Input protection

The unit has built-in protection against failure and burnout resulting from incorrect input value, typically:

The 24v DC supply is incorrectly connected to the setpoint input, the display will show 'OL', as an overload indication. The unit will need to be rewired and when correctly connected will operate normally.

The overload indicator 'OL' will also appear should the wrong input value be applied or the wrong input value be programmed: (0 - 10v instead of 4 - 20mA or conversely 4 - 20mA rather than 0 - 10V). To correct this a different set point value should be input or the unit reprogrammed to correct the set point value acceptance. (via parameter 4).

### Response times

To fill volume of 100cm<sup>3</sup>, connected to the outlet of the regulator:

Pressure increase from 2 to 4 bar (30 to 60 PSI) 30 msecs  
Pressure increase from 1 to 6 bar (15 to 90 PSI) 120 msecs  
Pressure decrease from 4 to 2 bar (60 to 30 PSI) 60 msecs  
Pressure decrease from 6 to 1 bar (90 to 15 PSI) 160 msecs

### Settings

The regulator is pre-set at the factory. If required, adjustments can be made.

## Flow characteristics

Flow characteristics (supply pressure 10 bar (150 PSI))

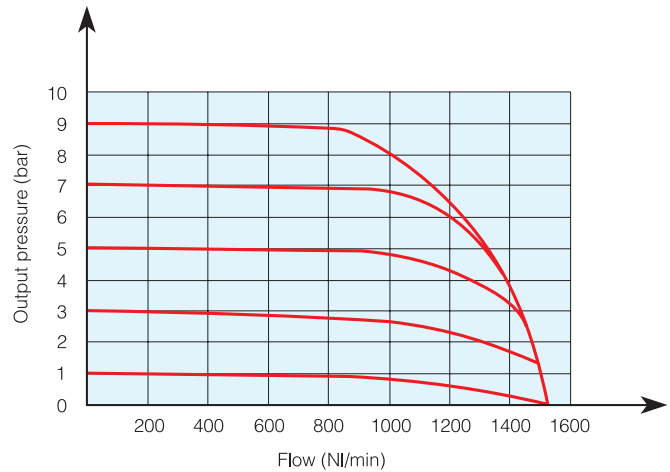

## How to change parameters

Pressing the Accept key "acc" for more than 3 seconds, will activate parameter change mode. The user can then select the parameters by pressing up or down key. (display will show Pxx). When parameter number is correct, pressing accept again will enter parameter value. (display will show parameter value).

Pressing the up or down key will change the parameter itself. (display will flash indicating parameter editing mode). Pressing the accept key will accept the new parameter value. (all digits will flash whilst being accepted).

After releasing all keys, the next parameter number will be presented on the display. (you may step to the next parameter). When no key is pressed, after 3 seconds the display will show the actual output pressure.

Only parameter numbers 0, 4, 9, 14, 18, 19, 20, 12, 13 and 21 are accessible to edit. All other parameters are fixed.

## Manual mode

When keys DOWN and UP are pressed during startup, (connecting to the 24V power supply) manual mode is activated. This means that the user is able to in/decrease the output pressure of the P3HP, by pressing the UP or DOWN key. During this action the display will blink, indicating that the manual mode is activated.











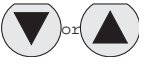

## Back to Factory Setting

After start up. (Power is on)

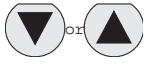
Entering this value in parameter 0 will store the calibrated factory data into the working parameters.

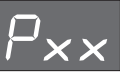
(Default calibration data is used)



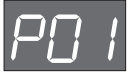









### Parameter Number 0 – Reset Back to Factory Settings

Step	1	2	3	4	5	
Press 	 3-6 seconds					
Until Display Reads			 Flashing Decimal	 Flashing Decimal	 Flashing	
Description	Accesses changeable parameters	Accesses parameter no. 0	Displays current parameter value.	Edits parameter. 3 = standard factory settings. If other than 3, use Up or Down Arrow and accept 3	Accepts and saves new parameter setting.	Sequences to next parameter.

## Set Control Signal

The unit is factory set for 0-10 V control signal. If 4-20 mA control signal is required, change parameter 4.













### Parameter Number 4 – Set Control Signal in Volts or Milliamps

Step	1	2	3	4	5	
Press 	 3-6 seconds					
Until Display Reads			 Flashing Decimal	 Flashing Decimal	 Flashing	
Description	Accesses changeable parameters	Accesses parameter no. 4	Displays current parameter value. 1 = V 0 = mA	Edits parameter	Accepts and saves new parameter setting.	Sequences to next parameter.

## Adjust Digital Display

If necessary, adjustments can be made to the digital display when using an external pressure sensor.

### Parameter Number 9 – Adjust Digital Display Value (Pressure Calibration)











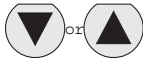

Step	1	2	3	4	5	
Press 	 3-6 seconds					
Until Display Reads			 Flashing Decimal	 Flashing Decimal	 Flashing	
Description	Accesses changeable parameters	Accesses parameter no. 9	Displays current digital display.	Use up or down arrows and accept to adjust the display value if using an external pressure sensor.	Accepts and saves new parameter setting.	Sequences to next parameter.

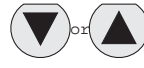
# Moduflex proportional technology

## Set Pressure Scale

Units with NPT port threads are supplied with a factory set PSI pressure scale. Use parameter 14 to change scale to bar.











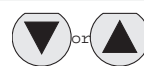

### Parameter Number 14 – Set Pressure Scale in PSI or bar

Step	1	2	3	4	5	
Press 	 3-6 seconds					
Until Display Reads			 Flashing Decimal	 Flashing Decimal	 Flashing	
Description	Accesses changeable parameters	Accesses parameter no. 14	Displays current parameter value. 1 = PSI 0 = bar	Edits parameter	Accepts and saves new parameter setting.	Sequences to next parameter.

## Preset Minimum Pressure

If there is a need for a pre-set minimum pressure, use parameter 18. (Note: preset pressure is affected by % P19.)

### Parameter Number 18 – Set Minimum Preset Pressure

Step	1	2	3	4	5	
Press 	 3-6 seconds					
Until Display Reads			 Flashing Decimal	 Flashing Decimal (value between 0 and 200)	 Flashing	
Description	Accesses changeable parameters	Accesses parameter no. 18	Displays current parameter value. Incremental value is: 2 bar unit: x 2 mbar x % P19 10 bar unit: x 10 mbar x % P19	Edits parameter	Accepts and saves new parameter setting.	Sequences to next parameter.

## Set Pressure Correction











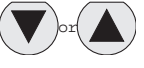

Pressure correction allows the user to set a maximum pressure as a percentage of secondary pressure F.S.

Example: If F.S. is 10 bar, set parameter 19 to 50 for maximum preset pressure of 5 bar.

Pressure correction also affects the minimum preset pressure in parameter 18.

Example: If F.S. is 10 bar and parameter 18 is set to a value of 100 (1 bar), and parameter 19 is set to 50%, then the actual minimum preset pressure seen is 0.5 bar.

### Parameter Number 19 – Set Maximum Preset Pressure













Step	1	2	3	4	5	
<b>Press</b> 	 3-6 seconds					
<b>Until Display Reads</b>			 Flashing Decimal	 Flashing Decimal (value between 0 and 100)	 Flashing	
<b>Description</b>	Accesses changeable parameters	Accesses parameter no. 19	Displays current parameter value. Incremental value is % of F.S.	Edits parameter	Accepts and saves new parameter setting.	Sequences to next parameter.

## Behavior Control

The regulation speed of the pressure regulator can be modified by means of one parameter. (P 20)

The value in this parameter has a range from 0-5. A higher value indicates slower regulation speed, but will be more stable.

### Parameter Number 20 – Set Behavior Control

Step	1	2	3	4	5	
<b>Press</b> 	 3-6 seconds					
<b>Until Display Reads</b>			 Flashing Decimal	 Flashing Decimal (value between 0 and 5)	 Flashing	
<b>Description</b>	Accesses changeable parameters	Accesses parameter no. 20	Displays current parameter value.	Edits parameter 0 = custom set* 1 = fastest (narrow proportional band) 2 = fast 3 = normal 4 = slow 5 = slowest (proportional band is broad)	Accepts and saves new parameter setting.	Sequences to next parameter.













\*When the value 0 is entered, you are able to create your own custom settings true parameters 12, 13 and 21.

## Fine Settings

### Set Proportional Band

Proportional band is used for setting the reaction sensitivity of the regulator. The displayed value is X 10 mbar and has a range between 50 (0.5 bar) and 250 (2.5 bar).











#### Parameter Number 12 – Set Proportional Band (P20 Must be Set to 0)

Step	1	2	3	4	5	
Press 	 3-6 seconds					
Until Display Reads			 Flashing Decimal	 Flashing Decimal (value between 50 and 250)	 Flashing	
Description	Accesses changeable parameters	Accesses parameter no. 12	Displays current parameter value. Incremental value is X 10 mbar.	Edits parameter	Accepts and saves new parameter setting.	Sequences to next parameter.

### Set Deadband



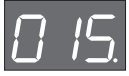

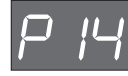







Deadband is the minimum limit of accuracy at which the regulator is set for normal operation. The displayed value is X 10 mbar and has a range between 2 (20 mbar) and 40 (400 mbar).

#### Parameter Number 13 – Set Deadband (P20 Must be Set to 0)







Step	1	2	3	4	5	
Press 	 3-6 seconds					
Until Display Reads			 Flashing Decimal	 Flashing Decimal (value between 2 and 40)	 Flashing	
Description	Accesses changeable parameters	Accesses parameter no. 13	Displays current parameter value. Incremental value is X 10 mbar.	Edits parameter	Accepts and saves new parameter setting.	Sequences to next parameter.

## Proportional Effect

### Parameter Number 21 – Set Proportional Effect (P20 Must be Set to 0)

Step	1	2	3	4	5	
<b>Press</b> 	 3-6 seconds					
<b>Until Display Reads</b>			 Flashing Decimal	 Flashing Decimal (value between 5 and 100)	 Flashing	
<b>Description</b>	Accesses changeable parameters	Accesses parameter no. 21	Displays current parameter value.	Edits parameter 5 = fastest regulation 100 = slowest regulation	Accepts and saves new parameter setting.	Sequences to next parameter.

### Parameter Number 39 – Displays Current Software Version

Step	1	2	3	
<b>Press</b> 	 3-6 seconds			
<b>Until Display Reads</b>			 Flashing Decimal	
<b>Description</b>	Accesses parameters	Accesses parameter no. 39	Displays current parameter value. XXX = current software version	

# Moduflex proportional technology

## Troubleshooting guide

Problem	Possible Reason	Solution
Display will not light up	No 24 volts power supply	Check if the wiring is connected according to the schematic wiring diagram
Unit will not, or not correctly respond to given setpoint	Wrong current applied ( I.e. Volt instead of mA or mA instead of Volt	Change setpoint current or re configure the setpoint current through the software by changing parameter 4  Check wiring if the setpoint signal lead is connected to the right pin within the male M12 connector ( should be pin 2)
	Setpoint signal is not stable enough	Stabilize setpoint signal input
Display shows NoP.	Unit detects that required output pressure is higher than the supplied pressure	Adjust the inlet pressure to a higher value, preferably 0,5 bar higher than requested output pressure  Give lower setpoint value which corresponds to a output pressure lower than the inlet pressure
	No inlet pressure at all	Connect port 1 to the supply pressure
Unit behaviour is not considered normal	Faulty settings made in the parameters	Reset the unit to factory settings by using the green key function under parameter 0
Desired pressure can not be reached	Setpoint value to low	Increase setpoint value
	Pre-set pressure limit has been changed to a lower max. outlet pressure	Change max. outlet pressure back to required pressure by changing parameter 19
	Supply pressure is to low	Increase supply pressure
Secondary side stays pressurized	Setpoint value is higher than 0,1 Volt	Lower your setpoint value, preferably to 0 Volts
	Pre-set pressure has been enabled to a certain pressure	Reset parameter 18 to 0
Display shows unrealistic value	Display maybe configured in the wrong value ( bar instead of psi)	Check through parameter 14, if the display value is set on either psi or bar, if necessary change it to the required setting
Unit response time too slow or too quick	Volume behind the unit is either too big or too small	Adjust the regulating speed of the unit through parameter 20
Unit gives too much overshoot	Relation between volume and response time is out of balance	Adjust response time to a higher value through parameter 20, to acheive more accurate behaviour
Unit is adjusting/regulating constantly	Airleakage in the system behind the unit	Resolve leakage
	Constant changing volume behind the unit	Unit needs to regulate to keep required pressure at the same level  Try to minimize the volume changes
	"Deadband "area is set too small	Enlarge deadband setting through parameter 13 in the software ( parameter 20 has to be set to 0 before changing parameter 13)
Can not enter software through touchpad	Unit is currently working/processing	Make sure that the unit is in steady state while activating the software
	Activating time is too short	Hold the accept button for at least 3 seconds
Display indicates 'OL'	Wiring not according to diagram (24 volt connected on the setpoint connection pin)	Rewire so that on the setpoint connection pin will be either 0-10v or 4-20mA
	Wrong setpoint value given in relation to programmed setpoint value acceptance	Change over setpoint value to either V or mA or Reprogramme the unit to the correct setpoint value via parameter 4
Any other problem		Please consult factory

### SALE CONDITIONS

The items described in this document are available for sale by Parker Hannifin Corporation, its subsidiaries or its authorized distributors. Any sale contract entered into by Parker will be governed by the provisions stated in Parker's standard terms and conditions of sale (copy available upon request).



## Dimensional drawings

### Bottom exhaust version

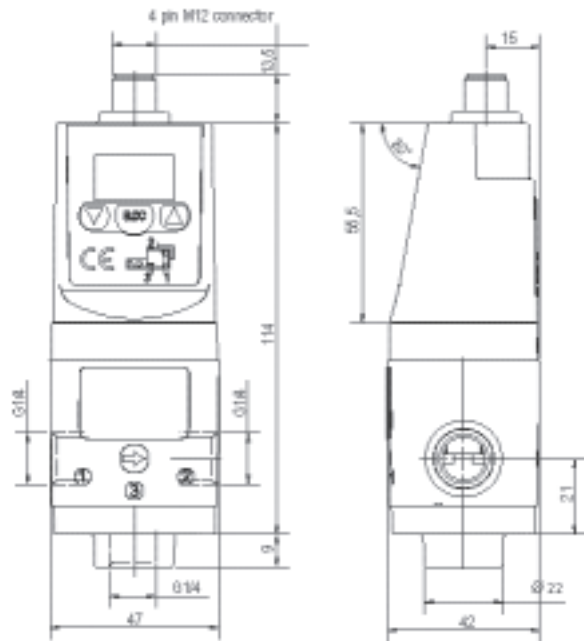

### Side exhaust version

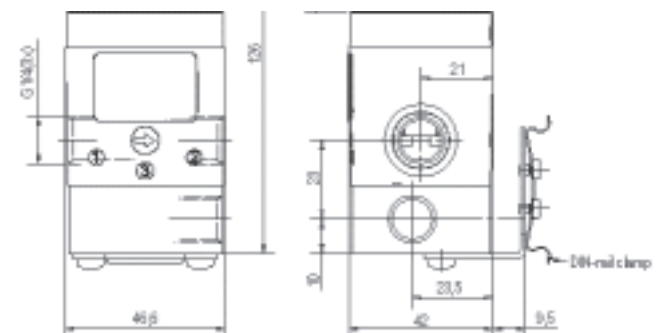
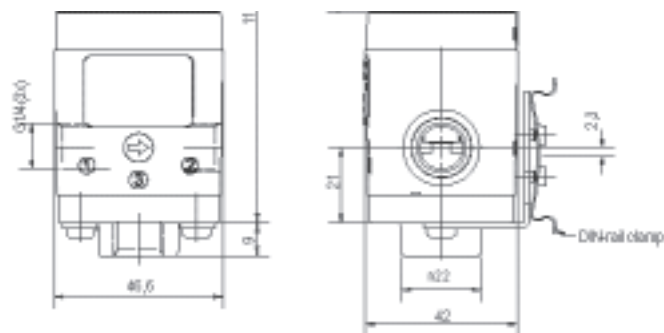
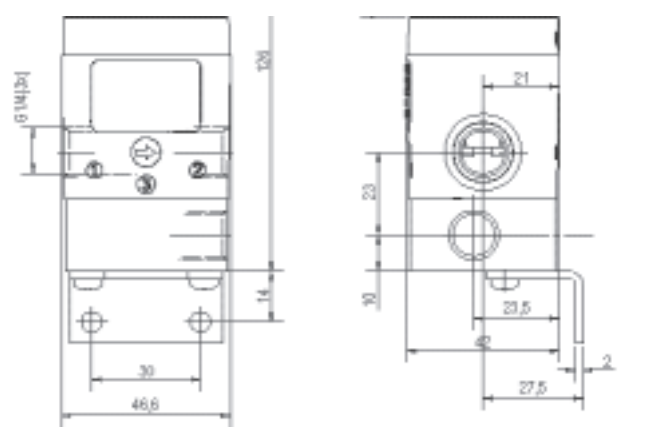
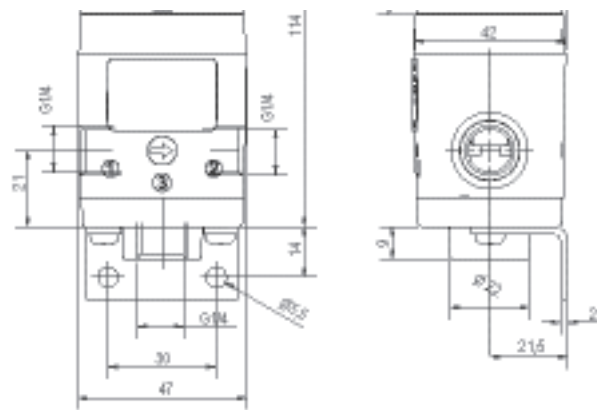
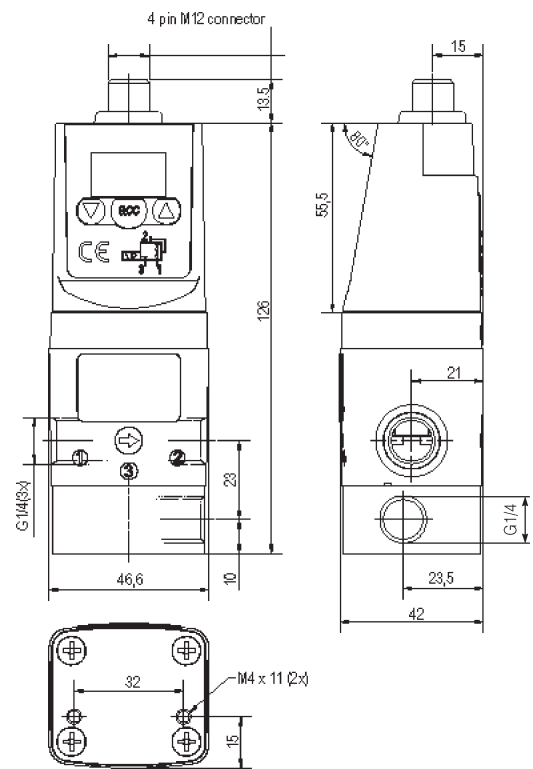

### WARNING

**FAILURE OR IMPROPER SELECTION OR IMPROPER USE OF THE PRODUCTS AND/OR SYSTEMS DESCRIBED HEREIN OR RELATED ITEMS CAN CAUSE DEATH, PERSONAL INJURY AND PROPERTY DAMAGE.**

This document and other information from Parker Hannifin Corporation, its subsidiaries and authorized distributors provide product and/or system options for further investigation by users having technical expertise. It is important that you analyze all aspects of your application and review the information concerning the product or system in the current product catalog. Due to the variety of operating conditions and applications for these products or systems, the user, through its own analysis and testing, is solely responsible for making the final selection of the products and systems and assuring that all performance, safety and warning requirements of the application are met. The products described herein, including without limitation, product features, specifications, designs, availability and pricing, are subject to change by Parker Hannifin Corporation and its subsidiaries at any time without notice.

## **Pneumatic Division Sales Offices**

---

**Austria - Wr.Neustadt**

Tel: +43 2622 23501  
Fax: +43 2622 66212

**Belgium - Nivelles**

Tel: +32 67 280 900  
Fax: +32 67 280 999

**Czech & Slovak  
Republics - Klecany**

Tel: +420 284 083 111  
Fax: +420 284 083 112

**Denmark - Ballerup**

Tel: +45 43 560400  
Fax: +45 43 733107

**Finland - Vantaa**

Tel: +358 9 4767 31  
Fax: +358 9 4767 3200

**France - Contamine**

Tel : +33 4 50 25 80 25  
Fax : +33 4 50 03 67 37

**Germany - Kaarst**

Tel: +49 2131 4016-0  
Fax: +49 2131 4016-9199

**Greece - Athens**

Tel: +30 210 933 6450  
Fax: +30 210 933 6451

**Hungary - Budapest**

Tel: +36 1 220 4155  
Fax: +36 1 422 1525

**Ireland - Dublin**

Tel: +353 1 293 9999  
Fax: +353 1 293 9999

**Italy - Corsico, Milan**

Tel: +39 02 4519 21  
Fax: +39 02 4479 340

**Netherlands - Oldenzaal**

Tel: +31 541 585000  
Fax: +31 541 585459

**Norway - Langhus**

Tel: +47 6491 1000  
Fax: +47 6491 1090

**Poland - Warsaw**

Tel: +48 22 573 24 00  
Fax: +48 22 573 24 03

**Portugal - Leça da  
Palmeira**

Tel: +351 22 999 7360  
Fax: +351 22 996 1527

**Romania - Bucharest**

Tel: +40 21 252 1382  
Fax: +40 21 252 3381

**Russia - Moscow**

Tel: +7 095 234 0054  
Fax: +7 095 234 0528

**Slovenia - Novo mesto**

Tel: +386 7337 6650  
Fax: +386 7337 6651

**Spain - Madrid**

Tel: +34 91 675 7300  
Fax: +34 91 675 7711

**Sweden - Spånga**

Tel: +46 (0) 8 5979 5000  
Fax: +46 (0) 8 5979 5120

**Switzerland**

Tel: +49 2131 4016-0  
Fax: +49 2131 4016-9199

**Turkey - Istanbul**

Tel: +90 212 482 91 06  
Fax: +90 212 482 91 10

**UK - Cannock**

Tel: +44 1543 456000  
Fax: +44 1543 456001

**Ukraine - Kiev**

Tel: + 380 44 220 7432  
Fax: + 380 44 220 6534

**Parker Hannifin plc**

Pneumatic Division,  
Walkmill Lane, Bridgtown,  
Cannock, Staffs. WS11 0LR  
United Kingdom

We reserve the right to make  
alterations without prior notification.  
Edition 05.12