

CYLINDRES

according to Standard ISO 15552 - VDMA 24562

Cylinders series 1319 ÷ 1321	3.0÷3.3
Cylinders, Non rotating series 1348 ÷ 1350	3.4÷3.7
Twin rod cylinders series 1325-1326 1345-1347	3.8÷3.11
Rotary actuators series 1330-1333	3.12÷3.15
Clean profile cylinders series 1380 ÷ 1382	3.16÷3.19
Accessories	3.20÷3.43
Sensor brackets	
Linear control units	
Piston rod lock	
Fixing devices	



General

This series of pneumatic cylinders is manufactured according to ISO 6431 standards adapted to VDMA 24562 and CNOMO/AFNOR 49003 that guarantee the interchangeability of the cylinders even without mounted anchoring.

It differs from the 1300 and 1303 series mainly due to the different pitch of the mounting holes on the end plates and of the barrel made of anodized and shaped aluminium; the tie rods have been eliminated for bores from 32 to 125 mm and the end covers are mounted directly on the barrel with special male/female screws, while for bore 160 and 200 mm it is still used the tie rods going through the barrel fixing holes.

The barrel is extruded on the inside to guarantee precision with low friction; oxydation hardens the sliding surface of the seals allowing work even without lubrication.

The magnetic piston can be mounted to activate the limit switch with Reed contact and all types of anchorings are available according to ISO-VDMA standards, that can be fixed to the end plates with socket head screws.

To order single acting cylinders (up to Ø 125, 50 mm maximum stroke), add to the code of the chosen cylinder abbreviation MA for the front spring and MP for the rear spring.

For example: **1320.32.50.01MA** **1320.50.25.01MP**

Construction characteristics

End plates	from Ø32 to Ø125: UNI 5079 aluminium alloy casting painted black by cataphoresis from Ø160 to Ø200: UNI 3051 aluminium chilled painted black by cataphoresis
Rod	chromed AISI 303 stainless steel or C43 chromed steel
Barrel	aluminium alloy, anodized 25 micron Ra = 0,3 ÷ 0,5
Cushion bushings	hardened aluminium
Rod-guide bushing	self-lubricating sintered bronze
Piston	vulcanized NBR 80 shore rubber monobloc on steel core with incorporated plastoferrite permanent magnet. NBR 80 shore rubber monobloc on without magnet for the non magnetic version plus rear spacer VITON® monobloc for high temperature, available on request for magnetic and non magnetic cylinder
Piston rod and cushion seals	self-lubricating 90 shore mixing polyurethane (VITON® on request for high temperature)
Other seals	rubber NBR 80 shore
Cushion adjustment screws	nickel-plated steel

Technical characteristics

Fluid	filtered and preferably lubricated air
Pressure	10 bar
Operating temperature	-5°C ÷ +70°C (VITON®, 150°C)
Bore	Ø 32 - 40 - 50 - 63 - 80 - 100 - 125 - 160 - 200
Cushioning length	mm 28 - 32 - 32 - 40 - 44 - 50 - 55 - 55 - 55

"Attention: Dry air must be used for application below 0°C"

Standard strokes (for all diameters)

from 0 up to 150, every 25 mm
over 150 up to 500, every 50 mm
over 500 up to 1000, every 100 mm

Stroke tolerance (ISO 15552)

Bore	Stroke	Tolerance
32 - 40 - 50	up to 500	+2 0
	over 500 up to 1250	+3,2 0
63 - 80 - 100	up to 500	+2,5 0
	over 500 up to 1250	+4 0
125 - 160 - 200	up to 500	+4 0
	over 500 up to 1250	+5 0

Drawing

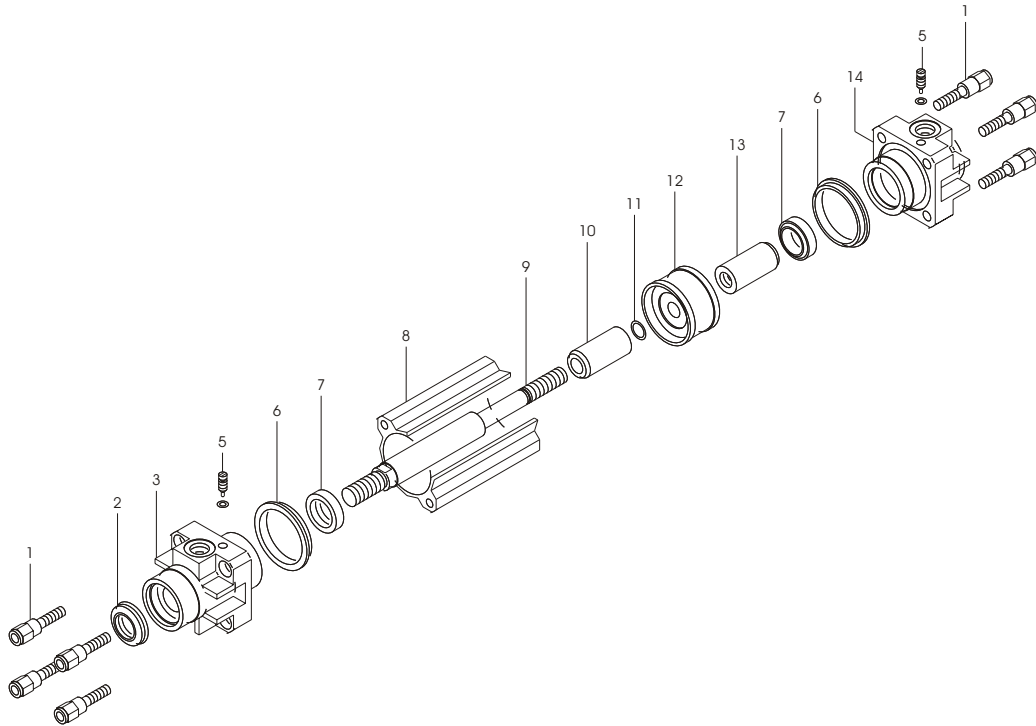

Pos.	Description	N. Pieces
1	Tie nut	8
2	Rod seal	1
3	Front cover	1
5	Cushioning adjustment screw	2
6	Cover seal	2
7	Cushion seal	2
8	Barrel	1
9	Rod	1
10	Front bushing cushion	1
11	Front bushing cushion seal	1
12	Piston	1
13	Rear bushing cushion	1
14	Rear cover	1



Basic version

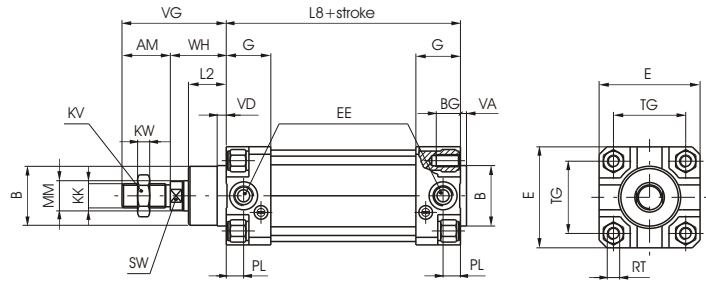

This is the configuration that represents the basic cylinder according to ISO-VDMA standards. It can be directly anchored on machine parts using the four thread on the end cover. For other applications see the following pages where different types of attachments are shown.

Ordering code
1319.Ø.stroke.01 magnetic chromed rod
1320.Ø.stroke.01 magnetic stainless steel chromed rod
1321.Ø.stroke.01 non magnetic chromed rod
13- -Ø.stroke.01V non magnetic VITON® seals

Push/Pull version

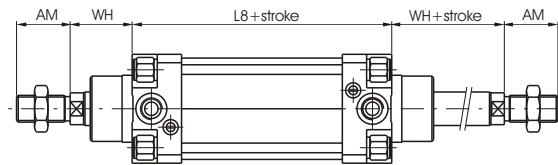

Ordering code
1319.Ø.stroke.02 magnetic chromed rod
1320.Ø.stroke.02 magnetic stainless steel chromed rod
1321.Ø.stroke.02 non magnetic chromed rod
13- -Ø.stroke.02V non magnetic VITON® seals

Tandem push with a common rod

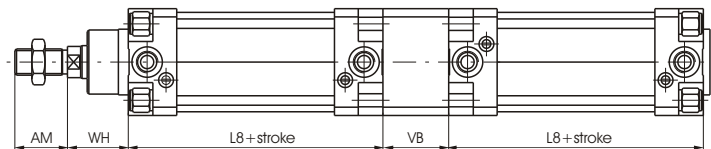

Ordering code
1319.Ø.stroke.G magnetic chromed rod
1320.Ø.stroke.G magnetic stainless steel chromed rod
1321.Ø.stroke.G non magnetic chromed rod

Tandem push with independent rods

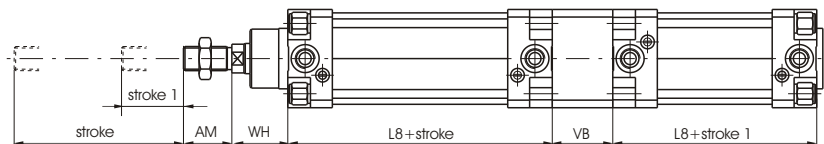

Ordering code
1319.Ø.stroke.stroke1.F magnetic chromed rod
1320.Ø.stroke.stroke1.F magnetic stainless steel chromed rod
1321.Ø.stroke.stroke1.F non magnetic stainless steel chromed rod

Opposed tandem with common rods

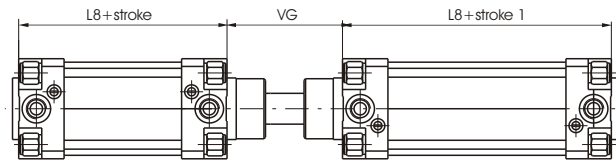

Ordering code

1319.Ø.stroke.stroke1.D magnetic chromed rod
1320.Ø.stroke.stroke1.D magnetic stainless steel chromed rod
1321.Ø.stroke.stroke1.D non magnetic chromed rod

Tandem with opposed rods

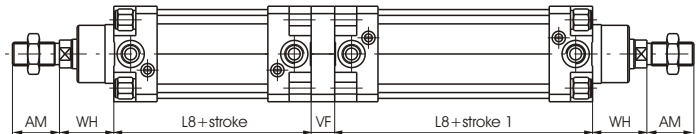

Ordering code

1319.Ø.stroke.stroke1.E magnetic chromed rod
1320.Ø.stroke.stroke1.E magnetic stainless steel chromed rod
1321.Ø.stroke.stroke1.E non magnetic chromed rod

Table of dimensions

Bore	32	40	50	63	80	100	125	160	200	
AM	22	24	32	32	40	40	54	72	72	
B (d 11)	30	35	40	45	45	55	60	65	75	
BG	12	12	16	16	20	20	20	24	24	
E	46	52	65	75	95	115	140	180	220	
EE	G 1/8"	G 1/4"	G 1/4"	G 3/8"	G 3/8"	G 1/2"	G 1/2"	G 3/4"	G 3/4"	
G	25	29	29,5	36	36	40	45	49	49	
KK	M10X1,25	M12X1,25	M16x1,5	M16x1,5	M20x1,5	M20x1,5	M27x2	M36x2	M36x2	
KV	17	19	24	24	30	30	41	55	55	
KW	6	7	8	8	9	9	12	18	18	
L 2	16	20	25	25	32	35	45	50	60	
L 8	94	105	106	121	128	138	160	180	180	
MM	12	16	20	20	25	25	32	40	40	
PL	9	11,5	13	14	16	18	19	24	24	
RT	M6	M6	M8	M8	M10	M10	M12	M16	M16	
SW	10	13	17	17	22	22	27	32	32	
TG	32,5	38	46,5	56,5	72	89	110	140	175	
VA	4	4	4	4	4	4	6	5	5	
VB	25	30	40	40	50	50	75	70	75	
VD	5	6	6	6	8	8	10	10	10	
VF	12	12	16	16	20	20	25	30	30	
VG	48	54	69	69	86	91	119	152	167	
WH	26	30	37	37	46	51	65	80	95	
Weight gr.	Stroke 0	480	730	1150	1600	2800	3600	7800	15000	21500
	every 10 mm	25	32	56	60	90	100	140	265	325